



Riduttori - motoriduttori ortogonali
Helical bevel gearboxes and geared motors
Kegelradgetriebe-Kegelradtriebemotoren

1.1	Caratteristiche costruttive	Construction features	Konstruktionsmerkmale	B3
1.2	Livelli di pressione sonora SPL [dB(A)]	Mean sound pressure levels SPL [dB(A)]	Schalldruckpegel SPL [dB(A)]	B4
1.3	Criteri di selezione	Gear unit selection	Auswahlkriterien	B5
1.4	Verifiche	Verification	Überprüfungen	B8
1.5	Stato di fornitura	Scope of the supply	Lieferzustand	B22
1.6	Normative applicate	Standards applied	Angewendete Normen	B26
1.7	Designazione	Designation	Bezeichnung	B30
1.8	Lubrificazione	Lubrication	Schmierung	B54
1.9	Prestazioni riduttori	Gear unit ratings	Leistungen der Getrieben	B58
1.10	Momenti d'inerzia	Moments of inertia	Trägheitsmomente	B78
1.11	Dimensioni	Dimensions	Applizierbare Motoren	B80
1.12	Estremità d'albero entrata	Input shaft end	Ende der Antriebswelle	B112
1.13	Accessori	Accessories	Zubehör	B113
1.14	KIT	KIT	KIT	B118



RXO - RXV

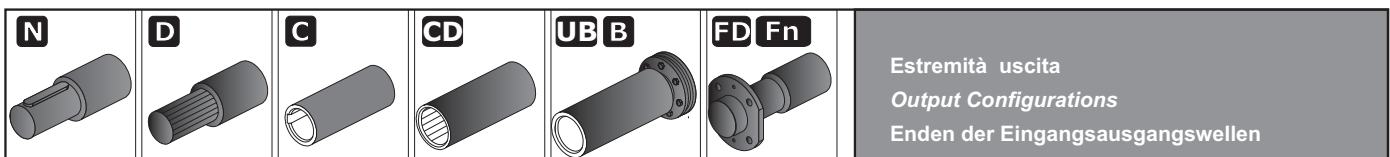

Estremità uscita
Output Configurations
Enden der Eingangsausgangswellen

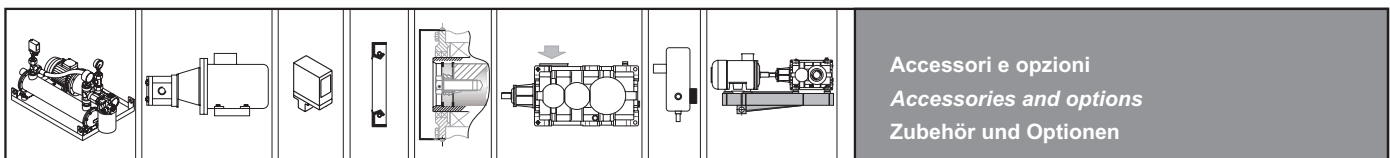

Accessori e opzioni
Accessories and options
Zubehör und Optionen



Posizioni di montaggio
Mounting positions
Einbaulagen

Gestione Revisione Cataloghi GSM
Managing GSM Catalog Revisions
Management Wiederholt Kataloge GSM

SIMBOLO SYMBOL SYMBOL	DEFINIZIONE	DEFINITION	DEFINITION	UNITA' DI MISURA MEASUREMENT UNIT MAßEINHEIT	
fa	Fattore correttivo dell'altitudine	Altitude factor	Höhenkorrekturwert		
Fa₁₋₂	Carico assiale	<i>Axial load</i>	Axialbelastung	N	1N=0.1daN ≅ 0.1kg
fc	Coefficiente relativo alla temperatura dell'aria	Air temperature factor	Koeffizient bezüglich der Lufttemperatur		
fd	Fattore correttivo del tempo di lavoro	Operation time factor	Korrekturfaktor der Arbeitszeit		
ff	Fattore correttivo di aerazione con ventola	Fan cooling factor	Korrekturfaktor der Belüftung durch Lüfter		
f_{Ga}	Fattore di affidabilità	Safety factor	Zuverlässigkeitsfaktor		
fm	Fattore correttivo per la posizione di montaggio	Mounting position factor	Korrekturfaktor für einbaulage		
f_n	Fattore correttivo delle prestazioni	Input speed factor	Korrekturfaktor der Leistungen		
fp	Fattore correttivo della temperatura	Ambient temperature factor	Korrekturfaktor der Umgebungstemperatur		
Fr₁₋₂	Carico Radiale	<i>Radial load</i>	Radialbelastung	N	1N=0.1daN ≅ 0.1kg
Fs	Fattore di servizio	<i>Service factor</i>	Betriebsfaktor		
Fs'	Fattore di servizio riduttore	<i>Gearbox service factor</i>	Betriebsfaktor Getriebe		
fv	Fattore correttivo	Duty cycle factor	Korrekturfaktor		
fw	Coefficiente relativo alla temperatura dell'acqua	Water temperature factor	Koeffizient bezüglich der Wassertemperatur		
IEC	Motori accoppiabili	<i>Motor options</i>	Passende Motoren		
ir	Rapporto di trasmissione	<i>Ratio</i>	Übersetzungsverhältnis		
J	Momento d'inerzia della macchina e del riduttore ridotto all'asse motore	Machine and gear unit inertial load reflected to motor shaft	An der Motorachse reduziertes Trägheitsmoment der Maschine und des Getriebe	Kgxm²	
J₀	Momento d'inerzia delle masse rotanti sull'asse motore	Inertial load of rotating parts at motor shaft	Trägheitsmoment der an der Motorachse drehenden Massen	Kgxm²	
kg	Massa	<i>Mass</i>	Masse	kg	
n₁	Velocità albero entrata	<i>Input speed</i>	Antriebsdrehzahl	min⁻¹	1 min ⁻¹ = 6.283 rad.
n₂	Velocità albero in uscita	<i>Output speed</i>	Abtriebsdrehzahl	min⁻¹	1 min ⁻¹ = 6.283 rad.
P	Potenza motore	<i>Gear unit power</i>	Leistung Getriebe	kW	
P'	Potenza richiesta in uscita	<i>Output power</i>	Erforderliche Abtriebsleistung	kW	
P₁	Potenza motoriduttore	<i>Gear motor power</i>	Leistung Getriebemotor	kW	1kW = 1.36 HP (PS)
P_c	Potenza corretta	<i>Correct power</i>	Tatsächliche Leistung	kW	
P_N	Potenza nominale	Nominal power	Nennleistung	kW	
P_{ta}	Potenza termica addizionale	Additional thermal power	Thermische Zusatzgrenzleistung	kW	
P_{tN}	Potenza termica nominale	Thermal power rating	Termische Nenngrenzleistung	kW	
P_{t0}	Potenza limite termico	<i>Limit thermal capacity</i>	Thermische Leistungsgrenze	kW	
RD (η)	Rendimento dinamico	<i>Dynamic efficiency</i>	Dynamischer Wirkungsgrad		
RS	Rendimento statico	<i>Static efficiency</i>	Statischer Wirkungsgrad		
T_{1f}	Coppia frenante dinamica	Dynamic braking torque	Dynamisches Bremsmoment	Nm	
T_{1max}	Coppia motrice massima	Max drive torque	Max. Antriebsmoment	Nm	
T_{1s}	Coppia motrice di spunto	Starting torque	Anlaufantriebsdrehmoment	Nm	
T_c	Temperatura ambiente	<i>Ambient temperature</i>	Umgebungstemperatur	°C	
T_N	Coppia nominale	Nominal torque	Nenndrehmoment	Nm, kNm	
T_{Tbr}	Coppia frenatura motore Autofrenante	Motor braking torque	Motorbremsmoment	Nm, kNm	
T_{1a}	Coppia limite in ingresso del dispositivo antiretro	income limit torque for back-stop device	Grenzantriebsmoment der Rücklaufsperr	Nm, kNm	
Q_{rid}	Quantità olio di riempimento del riduttore	Gearbox oil quantity	Öfüllmenge des Getriebes		
Q_{min}	Quantità olio minima	Minimum tank oil	Minimale Öfüllung im Tank	Nm, kNm	
M_{2s}	Coppia di slittamento calettatore	Shrink disc slipping torque	Schrumpfscheiben-Schlupfmoment	Nm, kNm	



RXO-V-700

700 Series



RXO-V-800

800 Series

RIDOTTORI - MOTORIDOTTORI ORTOGONALI
HELICAL BEVELGEARBOXES AND GEARED
MOTORS KEGELRADGETRIEBE -
KEGELRADGETRIEBEMOTOREN

RXO
RXV

700 Series

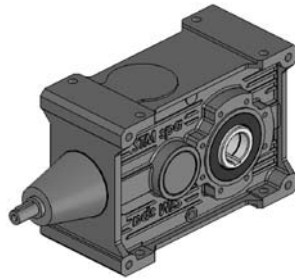

RXO

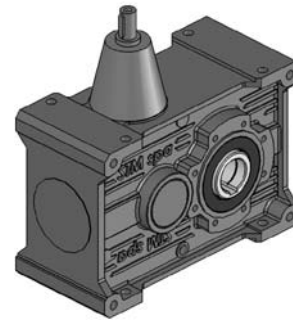

RXV

B

800 Series

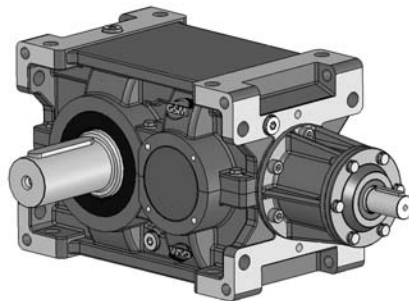

RXO

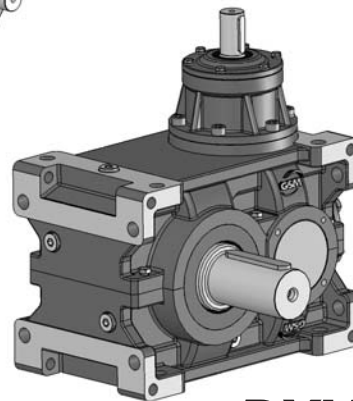

RXV

RX 800: La nuova gamma di riduttori ad assi ortogonali di forma universale, fissa un nuovo standard di riferimento sul mercato, avendo un adeguato dimensionamento atto a garantire la massima e costante affidabilità nelle condizioni di impiego più gravose.

Una risposta efficace alle esigenze di trasmissione di potenza dell'industria medio-pesante e pesante.

A completamento della gamma, abbiamo realizzato anche gli stessi riduttori con rapporti di riduzione molto lenti, lasciandovi quindi liberi di utilizzarli in una larga fascia applicativa.

RX 700: Dopo la presentazione dei riduttori della serie 800 è ora pronta la serie 700 ad assi ortogonali: il naturale completamento di gamma sulle basse potenze, per una linea di prodotto che fa storia da oltre 40 anni.

Carcassa monolitica rigida con molte predisposizioni di fissaggio, ingranaggi largamente dimensionati e numerosi accessori ed opzioni lo rendono un prodotto solido ed estremamente interessante..

RX 800: The new range of universal bevel helical gearboxes, establish a new standard on the market to refer to, having a suitable dimensioning fit for grant the maximum and constant reliability in the more heavy working conditions.

An effective answer to the power transmission requirements of the middle-heavy and heavy industry.

To complete the range, we also made the same gearboxes with a very low ratios, thus leaving you free to use in a wide range of application.

RX 700: Slightly after the market introduction of the gearboxes RX 800 line the bevel helical series RX 700 is now ready to be launched as a natural complementary range covering the low powers of a product line used as a market reference for longer than 40 years.

Sturdy monolithic housing with multiple fixing and connection positions, gears widely oversized and overrated as well as many accessories and options making it a strong and reliable product.

RX 800: Das neue Sortiment an Kegelstirnradgetrieben in einheitlicher Form setzt einen neuen Maßstab im Markt. Eine angemessene Größe gewährleistet die maximale und dauerhafte Zuverlässigkeit unter härtesten Einsatzbedingungen.

Ideal für die Kraftübertragungsanforderungen der Mittel- und Schwerindustrie..

RX 700: Nach der Präsentation der Getriebe der Serie 800 kommen wir nun zur Serie 700 mit Wälzgetriebe: als Vervollständigung des Low-Power Sortiments für eine Produktlinie die seit über 40 Jahren erfolgreich im Einsatz ist. Ein starres monolithisches Gehäuse mit vielen Befestigungsmöglichkeiten, reichlich dimensionierte Zahnräder sowie zahlreiches Zubehör und Optionen machen es zu einem soliden und äußerst interessantem Produkt

1.1 Caratteristiche costruttive

Le dimensioni dei nostri riduttori e i rapporti di trasmissione seguono la serie dei numeri normali (serie di RENARD) Ra 20 UNI 2016.68.

L'elevato numero di rapporti di trasmissione $i_N = (4 \div 4800)$, consente in alcuni casi di scegliere un riduttore di taglia inferiore.

L'ottimizzazione geometrica dell'ingranaggio unitamente ad una accurata lavorazione, assicura bassi livelli di rumorosità e garantisce elevati rendimenti:

1.1 Construction features

Gear unit dimensions and transmission ratios follow a geometric progression based on the Ra20 series of preferred (or Renard) numbers in accordance with UNI 2016.68.

Our broad range of transmission ratios $i_N = (4 \div 4800)$ and high ratio density frequently allows selection of a smaller size.

Optimal gear geometry and high machining accuracy ensure low noise levels and higher efficiency:

1.1 Konstruktionsmerkmale

Die Baugrößen und Übersetzungen unserer Getriebe sind der normalen Nummernserie (RENARD Reihe) Ra 20 UNI 2016.68 gemäß ausgelegt.

Die zahlreichen Übersetzungsverhältnisse $i_N = (4 \div 4800)$ räumen in einigen Fällen die Möglichkeit ein, ein kleineres Getriebe wählen zu können.

Die geometrische Optimierung des Zahnrads verbunden mit einer akkuraten Bearbeitung gewährleistet niedrige Geräuschentwicklung und einen hohen Wirkungsgrad:

Stadi/Stages/Stufig	Riduttore/Gearbox/Getriebe	RD (%) Rendimento/Efficiency/Wirkungsgrad
2	RXO-V 1	95
3	RXOV 2	93
4	RXO-V 3	91
5	RXO 4	90

1.2 Livelli di pressione sonora SPL [dB(A)]

Valori normali di produzione del livello medio di pressione sonora SPL (dB(A)) a velocità in entrata di 1450 min⁻¹ (tolleranza +3 dB(A)). Valori misurati ad 1 m dalla superficie esterna del riduttore ed ottenuti su elaborazione di prove sperimentali eseguite. Per raffreddamento artificiale con ventola sommare ai valori di tabella: +2 dB(A) per ogni ventola. Per entrata ad un numero di giri diverso sommare i valori come in tabella. Per particolari esigenze è possibile fornire riduttori con livello medio di pressione sonora ridotto.

1.2 Mean sound pressure levels SPL [dB(A)]

Noise levels are mean sound pressure levels SPL (dB(A)) and refer to normal operation at an input speed of 1450 rpm (tolerance +3 dB(A)). Measurements are taken at 1 m from the external surface of the gear unit and ratings are obtained by processing test data. For fan-cooled applications, add 2dB(A) to table values for each fan. For different input speeds, add the appropriate values indicated in the table below. Gear units with lower noise levels to suit particular needs are available on request.

1.2 Schalldruckpegel SPL [dB(A)]

Normale Werte des durchschnittlichen Schalldruckpegels SPL (dB(A)) bei einer Antriebsdrehzahl von 1450 U/min (Toleranz +3 dB(A)). Werte, die aus den Auswertungen der erfolgten experimentellen Tests, bei denen die Messung in 1 m Entfernung von der Getriebeoberfläche erfolgte, resultieren. Bei Vorliegen einer Zusatzluftkühlung durch Lüfter muss ein Korrekturwert von +2 dB(A) pro Lüfterrad zum Tabellenwert addiert werden. Bei abweichender Antriebsdrehzahl sind die Werte gemäß Tabellenangaben zu addieren. Im Fall besonderer Anforderungen können Getriebe mit einem reduzierten durchschnittlichen Schalldruckpegel geliefert werden.

		RXO1		RXO2 - RXV2		RXO3 - RXV3		RXO4	
		$i \leq 14$	$i > 14$	$i \leq 50$	$i > 50$	$i \leq 250$	$i > 250$	all	
RX 700 Series	700	Valori indicativi massimi 75 dB(A) / Maximum approximate value of 75 dB(A) / Max. Anhaltswerte 75 dB (A)							—
RX 800 Series	802	78	73	73	68	69	64	67	
	804	79	74	74	69	70	65	68	
	806	81	76	76	71	72	67	71	
	808	82	77	77	72	73	68	72	
	810	84	79	79	74	75	70	72	
	812	85	80	80	75	76	71	73	
	814	87	82	82	77	78	73	73	
	816	89	84	84	79	80	75	73	
	818	91	86	86	81	82	78		
	820	93	88	88	83	84	80		
	822	95	90	90	85	86	82		
	824	97	92	92	87	88	84		
	826			94	89	90	86		
	828			96	91	92	88		
830			98	93	94	90			
832					95	91			
n_1 [min⁻¹]	2750	2400	2000	1750	1000	750	500	350	
Δ SPL [dB(A)]	8	6	4	2	-2	-3	-4	-6	

1.3 Criteri di selezione

Conosciuti i dati dell'applicazione calcolare:

$$ir = n_1/n_2;$$

$$P1 = \frac{T_{2n} \times n_2 \times 100}{9550 \times RD\%};$$

n_1 - Velocità albero entrata;
 n_2 - Velocità albero uscita;
 ir - Rapporto di trasmissione;
 $RD\%$ - Rendimento dinamico;
 $P1$ - Potenza macchina motrice;
 T_{2n} - Coppia Uscita Nominale Applicazione

Per selezionare il riduttore è necessario che sia soddisfatta la seguente relazione:

1.3 Gear unit selection

Locate application information and determine:

$$ir = n_1/n_2;$$

$$P1 = \frac{T_{2n} \times n_2 \times 100}{9550 \times RD\%};$$

n_1 - Input shaft speed;
 n_2 - Output shaft speed;
 ir - Ratio;
 $RD\%$ - Dynamic efficiency;
 $P1$ - Input power;
 T_{2n} - Application nominal output torque

For gearbox selection the following is necessary:

1.3 Auswahlkriterien

Sind die Daten der Anwendung bekannt, ist wie folgt zu kalkulieren:

$$ir = n_1/n_2;$$

$$P1 = \frac{T_{2n} \times n_2 \times 100}{9550 \times RD\%};$$

n_1 -Drehzahl Antriebswelle;
 n_2 - Drehzahl Abtriebswelle;
 ir - Übersetzung;
 $RD\%$ - Dynamischer Wirkungsgrad;
 $P1$ - Antriebsleistung;
 T_{2n} - Effektivmoment

Für die Getriebeauswahl ist folgendes zu beachten:

Potenza
Power
Leistung

$$P_N \times fn \geq P_1 \times Fs$$

Coppia
Torque
Drehmoment

$$T_N \times fn \geq T_{2n} \times Fs$$

Il valore di T_N è riportato nelle schede tecniche di prodotto.
 Le potenze e i momenti torcenti indicati a catalogo nominali sono validi per $Fs=1$.

Fs - fattore di Servizio
 fn - Fattore correttivo delle prestazioni

Scegliere gli stadi, il rapporto, la grandezza, l'esecuzione, la forma costruttiva e verificare le dimensioni del riduttore e di eventuali accessori o particolari estremità.

The T_N value is write on the product technical sheets.
 Power and torque ratings stated in the catalogue refer to service factor $Fs=1$.

Fs - Service factor
 fn - Input speed factor

Select number of stages, ratio, size, shaft arrangement and design configuration and then check the dimensions of gear unit and any accessories or particular input/output configurations you have selected.

Den Wert von T_N finden sie auf den technischen Produkt-Datenblättern
 Die im Katalog angegebenen Nennleistungen und -drehmomente sind für $Fs=1$ gültig.

Fs - Betriebsfaktor
 fn - Korrekturfaktor der leistungen

Die Stufen, Übersetzung, Größe, Ausführung sowie Bauform wählen und die Größe des Getriebes und des eventuellen Zubehörs oder besondere Wellenenden überprüfen.



1.3 Criteri di selezione

Fattore di servizio - Fs

Il fattore di Servizio Fs dipende:

- a) dalle condizioni di applicazione
- b) dalla durata di funzionamento h/d
- c) avviamenti /ora
- d) dal grado di affidabilità o margine di sicurezza voluto .

Il fattore di servizio per casi specifici può essere assunto direttamente, altrimenti può essere calcolato in base ai singoli fattori: fattore di durata di funzionamento fs, dal numero di avviamenti /ora fv e dal fattore di sicurezza o grado di affidabilità fGa.

Le potenze e i momenti torcenti indicati a catalogo nominali sono validi per Fs=1.

1.3 Gear unit selection

Service factor - Fs

Service factor Fs is determined on the basis of:

- a) operating conditions of application
- b) operation per day (h/d)
- c) starts and stops per hour
- d) desired reliability or safety factor.

Where service conditions allow it, the recommended service factor for a specific application may be used directly, otherwise the service factor must be calculated and the following factors must be considered: operation time factor fs, duty cycle factor fv and safety or reliability factor fGa.

Power and torque ratings stated in the catalogue refer to service factor Fs=1.

1.3 Auswahlkriterien

Betriebsfaktor - Fs

Der Betriebsfaktor Fs hängt von folgenden Kriterien ab:

- a) Einsatzbedingungen
- b) Betriebsdauer h/d
- c) Anläufe / Stunden
- d) Zuverlässigkeitsgrad oder gewünschter Sicherheitsbereich.

In spezifischen Fällen kann der Betriebsfaktor direkt übernommen werden, andernfalls kann er den einzelnen Faktoren gemäß berechnet werden: Betriebsdauerfaktor fs, Anläufe/Stunde fv und Sicherheitsfaktor oder Zuverlässigkeitsgrad fGa.

Die im Katalog angegebenen Nennleistungen und -drehmomente sind für Fs=1gültig.

$$F_s = f_s \times f_v \times f_{Ga}$$

fs

Fattore di durata di funzionamento
Operation time factor
Betriebsdauerfaktor

Macchina motrice / Prime mover / Kraftmaschine	h/d	Macchina utilizzatrice Driven Machine Arbeitsmaschine		
		U	M	S
Motori elettrici, Turbine, Motori oleodinamici <i>Electric motors, Turbines, Hydraulic motors</i> Elektrische Motoren, Turbinen, hydraulische Motoren	2	0.8	1.0	1.4
	4	0.9	1.12	1.6
	8	1.0	1.25	1.75
	16	1.25	1.5	2.0
	24	1.5	1.75	2.25
Motori alternativi 4-6 cilindri <i>Combustion engines with 4-6 cylinders</i> Verbrennungsmotoren 4-6 Zylinder	2	0.9	1.12	1.6
	4	1.0	1.25	1.75
	8	1.25	1.5	2.0
	16	1.5	1.75	2.25
	24	1.75	2.0	2.5
Motori alternativi 1-3 cilindri <i>Combustion engines with 1-3 cylinders</i> Verbrennungsmotoren 1-3 Zylinder	2	1.0	1.25	1.75
	4	1.25	1.5	2.0
	8	1.5	1.75	2.25
	16	1.75	2.0	2.5
	24	2.25	2.5	3.0

U = macchina a carico uniforme
M = macchina con urti moderati
S = macchina con urti severi

U = Uniform load
M = Moderate shock load
S = Heavy shock load

U = Maschine mit gleichmäßiger Last
M = Maschine mit mäßigen Stößen
S = Maschine mit harten Stößen

h/d = ore di funzionamento giornaliero

h/d = hours of operation per day

h/d = Betriebsstunden/Tag



- 1 - Per i moltiplicatori di velocità, moltiplicare i valori di fs per 1.1
- 2 - Qualora il motore elettrico sia autofrenante è necessario moltiplicare i valori di fs per 1.1.

- 1 - For speed multipliers, multiply fs by 1.1
- 2 - When you've the brake electric motor, it's needed multiply the fs values for 1.1.

- 1 - Für Geschwindigkeits-Multiplikatoren die fs-Werte mit 1.1 multiplizieren
- 2 - Beim Einsatz von Bremsmotoren sind die fs-Werte mit 1,1 zu multiplizieren.

1.3 Criteri di selezione
Classificazione dell'applicazione

1.3 Gear unit selection
Application classification

1.3 Auswahlkriterien
Klassifikation der Anwendungsbereiche

	SETTORE DI APPLICAZIONE	APPLICATION SECTOR	ANWENDUNGSBEREICHE
U M	AGITATORI	AGITATORS	MISCHER
	Con densità uniforme Con densità non uniforme	<i>Uniform product density</i> <i>Variable product density</i>	mit gleichmäßiger Dichte keine gleichmäßige Dichte
U M	ALIMENTARE	ALIMENTARY	LEBENSMITTELBEREICH
	Maceratori, bollitori, coclee Trituratrici, sbucciatrici, scatoiatrici	<i>Mashers, boilers, screw feeders,</i> <i>blenders, peelers, cartoners</i>	Stampfmühlen, Kocher, Schnecken Zerkleinerer, Schälmaschinen, Einschachtelmaschinen
(1)U,M M S	ARGANI	WINCHES	SEILWINDEN
	Sollevamento Trascinamento Bobinatori	<i>Lifting</i> <i>Dragging</i> <i>Reel winders</i>	Heben Ziehen Aufrollen
U M S	CARTARIO	PAPER MILLS	PAPIER
	Avvolgitori, essiccatrici, pressatrici, Mescolatrici, estrusori, addensatrici Tagliatrici, lucidatrici	<i>Winders, dryers, couch rolls</i> <i>Mixers, extruders, thickeners</i> <i>Cutters, glazing cylinders</i>	Aufwickler, Trockner, Pressen, Mischer, Extruder, Verdichter, Schneidevorrichtungen, Poliermaschinen
S M	CHIMICO	CHEMICAL	CHEMIE
	Estrusori, stampatrici Impiatrici	<i>Extruders, printing presses</i> <i>Mixers</i>	Extruder, Drucker Vermischer
U M M	COMPRESSORI	COMPRESSORS	KOMPRESSOREN
	Centrifughi Rotativi Assiali	<i>Centrifugal</i> <i>Rotating</i> <i>Axial piston</i>	schleudernde rotierende axiale
M S	DRAGHE	DREDGES	BAGGER
	Trasportatori Estratrici, teste fresatrici	<i>Conveyors</i> <i>Extractors, cutter head drives</i>	Förderer Auszugsvorrichtungen, Fräsköpfe
M M S	EDILIZIA	BUILDING	BAUWESEN
	Betoniere, coclee Frantoi, dosatrici Frantumatrici	<i>Cement mixers, screw feeders</i> <i>Crushers, batchers</i> <i>Stone breakers</i>	Betonmischer, Schnecken Mühlen, Dosiervorrichtungen Brecher
U M M	ELEVATORI	ELEVATORS	HEBER
	A nastro, scale mobili A tazza, montacarichi, skip Ascensori, ponteggi mobili	<i>Belt type, escalators</i> <i>Bucket conveyors, hoists, skip hoists</i> <i>Public lifts, mobile scaffolding</i>	Mit Förderband, Rolltreppen Becherwerke, Lastenaufzüge, Skips Lifte, mobile Gerüste
M M (1)U,M	GRU	CRANES	KRÄNE
	Traslazione Rotazione Sollevamento	<i>Translation</i> <i>Slew</i> <i>Lifting</i>	Verfahren Drehen Heben
M M M	LEGNO	WOOD	HOLZ
	Accatastatori Trasportatori Seghe, piallatrici, fresatrici	<i>Stackers</i> <i>Transporters</i> <i>Saws, thicknessers, routers</i>	Stapler Förderer Sägen, Hobelmaschine, Fräsen
M M S	MACCHINE UTENSILI	MACHINE TOOLS	WERKZEUGMASCHINEN
	Alesatrici, brocciatrici, cesoiatrici Pieiatrici, stampatrici Magli, laminatoi	<i>Boring machines, broaching</i> <i>machines, shearing machines</i> <i>Bending machines, press forgers</i> <i>Power hammers, rolling mills</i>	Bohrer, Räummaschine, Schneidemaschinen Biegemaschinen, Stanzmaschinen Gesenkhammer, Walzwerke
U M	MESCOLATORI-MISCELATORI	MIXERS	MISCHER
	Con densità uniforme Con densità non uniforme	<i>Uniform density product</i> <i>Variable density product</i>	Mit gleichmäßiger Dichte Keine gleichmäßige Dichte
S M	MOVIMENTO TERRA	EARTH MOVING MACHINERY	ERDBEWEGUNG
	Escavatrici rotative a pale Trasportatori	<i>Rotating shovel excavators</i> <i>Transporters</i>	Schaufelbagger Förderer
U M,S M,S	POMPE	PUMPS	PUMPEN
	Centrifughe Volumetriche a doppio effetto Volumetriche a semplice effetto	<i>Centrifugal</i> <i>Double acting volumetric</i> <i>Single acting volumetric</i>	Zentrifugalpumpen Doppeleffekt-Verdrängerpumpe Verdrängerpumpe
U M	TRASPORTATORI	CONVEYORS	FÖRDERER
	Su rotaie A nastro	<i>On rails</i> <i>Belts</i>	Auf Rädern Mit Band
M M U	TRATTAMENTO ACQUE	WATER TREATMENT	WASSERAUFBEREITUNG
	Coclee, trituratori Mescolatori, decantatori Ossigenatori	<i>Screw feeders, disintegrators</i> <i>Mixers, settlers</i> <i>Oxygenators</i>	Schnecken, Zerkleinerer Mischer, Dekanter Sauerstoffgeräte
U M	VENTILATORI	FAN UNITS	VENTILATOREN
	Di piccole dimensioni Di grandi dimensioni	<i>Small</i> <i>Large</i>	Kleine Große

1) Per la scelta del fs secondo F.E.M. /1.001/1987 consultare il capitolo "sollevamento".

1) For fs selection in accordance with F.E.M. /1.001/1987, please read Chapter "Lifting".

1) Bei der Wahl des fs gemäß F.E.M. /1.001/1987 Bezug auf das Kapitel "Heben" nehmen.

1.3 Criteri di selezione

1.3 Gear unit selection

1.3 Auswahlkriterien

f_v

Numero di avviamenti /ora
Duty cycle factor
Anläufe/Stunde

f_v è il fattore correttivo del fattore di servizio F_s, per tenere conto degli avviamenti/ora. Il fattore di servizio F_s deve aumentare in caso di avviamenti frequenti con coppia di spunto notevolmente maggiore di quella di regime tenendo conto degli avviamenti per ora secondo la seguente tabella.

This correction factor is used to adjust service F_s to reflect the number of starts per hour. Where an application involves frequent starts at a starting torque significantly greater than running torque, service factor f_s must be adjusted to account for the number of starts per hour using the factors indicated in following table.

Anläufe/Stunde f_v ist Korrekturfaktor des Betriebsfaktors F_s unter Berücksichtigung der Anläufe/Std. Der Betriebsfaktor F_s muss bei häufigen Anläufen mit einem erheblich über dem Nenndrehmoment liegenden Anlaufmoment angehoben werden, wobei die Anläufe pro Stunde gemäß nachstehender Tabelle zu berücksichtigen sind.

f _v	Avv/h - Starts/minute - Anl./Std.	U	M	S
	Z ≤ 5	1	1	1
5 < Z ≤ 30	1.2	1.12	1.06	
30 < Z ≤ 63	1.33	1.2	1.12	
63 < Z	1.5	1.33	1.2	

f_{Ga}

Fattore affidabilità
Safety factor
Zuverlässigkeitsfaktor

Un margine di sicurezza o di affidabilità è già inserito nella prestazione di catalogo del riduttore. Se per particolari esigenze è necessaria un' affidabilità maggiore si aumenti il fattore di servizio ed in particolare si può dare i seguenti fattori:

Catalogue ratings incorporate a safety or reliability factor as standard. If greater reliability is required to meet specific requirements, service factor must be increased using the following factors

Die Katalogangaben der Getriebeleistungen enthalten bereits einen Sicherheitsbereich oder Zuverlässigkeitsgrad. Falls aufgrund besonderer Anforderungen ein höherer Zuverlässigkeitsgrad verlangt wird, muss der Betriebsfaktor unter Bezugnahme insbesondere auf folgende Faktoren gesteigert werden.

	Grado di affidabilità normale Standard safety factor Normaler Zuverlässigkeitsfaktor	Grado di affidabilità elevato (difficoltà di manutenzione, grande importanza del riduttore nel ciclo produttivo, sicurezza per le persone, ecc...) High safety factor (recommended for difficult maintenance situations, where gear unit performs a critical task in the overall production process or a task such to affect the safety of people, etc...) Hoher Zuverlässigkeitsgrad (schwierige Instandhaltung, für den Produktionszyklus besonders wichtiges Getriebe, Personenschutz, usw....)
f _{Ga}	1.0	1.25 - 1.4

f_n

Fattore correttivo delle prestazioni
Input speed factor
Korrekturfaktor der Leistungen

Fattore correttivo delle prestazioni nominali per tenere conto delle velocità in entrata n₁>1450 min⁻¹

This correction factor is used to adjust performance ratings to account for input speeds n₁>1450 min⁻¹

Korrekturfaktor der Nennleistungen unter Berücksichtigung der Eingangsdrehzahlen n₁>1450 min⁻¹

f _n	RX 700 Series	1.0	Il valore di T _N (2850 rpm) è riportato nelle schede tecniche di prodotto The T _N (2850 rpm) value is write on the product technical sheets Den Wert von T _N (2850 rpm) finden sie auf den technischen Produkt-Datenblättern					
f _n	RX 800 Series	n ₁ [min ⁻¹]	i _N ≤ 8		8 < i _N < 80		i _N ≥ 80	
			T _N	P _N	T _N	P _N	T _N	P _N
		2750	0.82	1.56	0.90	1.71	1.00	1.90
		2400	0.85	1.41	0.92	1.52	1.00	1.66
		2000	0.90	1.24	0.94	1.30	1.00	1.38
		1750	0.94	1.13	0.97	1.17	1.00	1.21
1450	1.00	1.00	1.00	1.00	1.00	1.00		

1.4 Verifiche

- 01** 1) Compatibilità dimensionale con ingombri disponibili (es diametro del tamburo) e delle estremità d'albero con giunti, dischi o pulegge.
- 02** 2) Compatibilità del rapporto selezionato con l'esecuzione albero cavo.
- 03** 3) Massimo sovraccarico nel caso di:
 - inversioni di moto per effetti inerziali,
 - commutazioni da bassa ad alta polarità,
 - avviamenti e frenature a pieno carico con grandi momenti d'inerzia (soprattutto nel caso di bassi rapporti),
 - sovraccarichi, urti od altri effetti dinamici:

1.4 Verification

- 1) *Ensure that dimensions are compatible with space constraints (for instance, drum diameter) and shaft ends are compatible with any couplings, discs or pulleys to be used.*
- 2) *Ensure that selected ratio is available for the hollow shaft configuration.*
- 3) *Determine maximum overload in the event of:*
 - reversing due to inertia,
 - switching from low to high polarity,
 - starts and stops under full load with high moment of inertia (this is especially important for low ratios),
 - overload, shock load or other dynamic load conditions:

1.4 Überprüfungen

- 1) Kompatibilität der Abmessungen mit verfügbaren Maßen (z.B. Trommeldurchmesser) und der Wellenenden mit den Kupplungen, Scheiben oder Riemenscheiben.
- 2) Kompatibilität des gewählten Übersetzungsverhältnisses mit der Ausführung der Hohlwelle.
- 3) Maximale Überlast im Fall von:
 - Drehrichtungs-Umkehr aufgrund von Trägheitseffekten,
 - Umschaltung von niedriger auf hohe Polarität,
 - Anläufe und Bremsungen unter Vollast mit hohen Trägheitsmomenten (vor allem bei niedrigen Übersetzungsverhältnissen),
 - Überlasten, Stöße oder andere dynamische Effekte.

1.4 Verifiche

Nel caso di avviamenti T_{2max} può essere considerata come quella parte della coppia accelerante (T_{2acc}) che passa attraverso l'asse lento del riduttore:

Avviamento

1.4 Verification

For starting, T_{2max} may be considered as that portion of acceleration (T_{2acc}) passing through the gear unit output (low speed) shaft:

Starting

1.4 Überprüfungen

Bei Anläufen kann T_{2max} als der Teil des Beschleunigungsmoments (T_{2acc}), der durch die Abtriebsachse des Getriebes läuft, angesehen werden:

Anlauf

$$T_{2max} = T_{2acc} = \left((0.45 \cdot (T_{1s} + T_{1max}) \cdot ir \cdot \eta) - T_{2n} \right) \cdot \left(\frac{J}{J + J_0 \cdot \eta} \right) + T_{2n} \quad [Nm]$$

dove:

J: momento d'inerzia della macchina e del riduttore ridotto all'asse motore (kgm^2)
 J_0 : momento d'inerzia delle masse rotanti sull'asse motore (kgm^2)
 T_{1s} : coppia motrice di spunto (Nm)
 T_{1max} : coppia motrice max (Nm)

Where:

J: machine and gear unit inertial load reflected to motor shaft (kgm^2)
 J_0 : inertial load of rotating parts at motor shaft (kgm^2)
 T_{1s} : starting torque (Nm)
 T_{1max} : max drive torque (Nm)

Hier ist:

J: An der Motorachse reduziertes Trägheitsmoment der Maschine und des Getriebes (kgm^2)
 J_0 : Trägheitsmoment der an der Motorachse drehenden Massen (kgm^2)
 T_{1s} : Anlaufantriebsdrehmoment (Nm)
 T_{1max} : Max. Antriebsmoment (Nm)

E' necessario che sia soddisfatta la seguente relazione:

The following formula must be satisfied:

Folgende Bedingung muss erfüllt sein:

$$T_{2max} < 2xT_N$$

04 4) Numero massimo di giri in entrata n_{1max}

4) Check maximum input speed n_{1max}

4) Max. Antriebsdrehzahl n_{1max}

RX 700 Series

Tutte le prestazioni dei riduttori sono calcolate in base a 2850, 1450, 1000 e 500 giri in entrata.

Velocità inferiori a 1400 min⁻¹ ottenute con l'ausilio di riduzioni esterne o di azionamenti, sono sicuramente favorevoli al buon funzionamento del riduttore, il quale può operare con temperature di funzionamento inferiori a vantaggio di tutto il cinematismo.

Per velocità inferiori a 900 min⁻¹ consultare il nostro Servizio Tecnico Commerciale.

All performances of geraboxes are calculated according to 2850, 1450, 1000 and 500 input rpm.

Speeds lower than 1400 min⁻¹ obtained by means of external reductions or drives, surely contribute to the good working of the gearbox which can operate at lower working temperatures to the advantage of the whole kinematic movement.

In case of input speed below 900 min⁻¹ please refer to our Technical Commercial Office.

Alle Leistungen der Getriebe werden auf der Grundlage folgender Antriebsdrehzahlen berechnet: 2850, 1450, 1000 und 500 min⁻¹. Drehzahlen unter 1400 min⁻¹, die mit Hilfe äußerer Untersetzungen oder Antriebe erhalten werden, sind für den optimalen Betrieb des Getriebes vorteilhaft, denn so kann dieses mit niedrigen Betriebstemperaturen arbeiten, was sich zum Vorteil der gesamten Getriebegruppe auswirkt.

Für Geschwindigkeiten unter 900 min⁻¹ wenden sie sich bitte an unsere Technische Abteilung.

RX 800 Series

n ₁ max (rpm)	ir	802		804		806		808		810		812		814		816		818		820		
		splash oil	splash oil	splash oil	forced lubric.	splash oil	forced lubric.	splash oil	forced lubric.	splash oil	forced lubric.	splash oil	forced lubric.	splash oil	forced lubric.	splash oil	forced lubric.	splash oil	forced lubric.	splash oil	forced lubric.	
RXO1	4.3-13.3	3500	3500	2900	3500	2900	3500	2500	2900	2500	2900	2000	2500	1750	2500	1500	2000	1500	2000	1500	2000	
RXV1	13.4-28.6			3500		3500		2900	3500	2900	3500	2900	3500	2900	3500	2500	2900	2500	2900	2000	2900	2000
RXO2	19-54.6	3500	3500	3500	3500	3500	3500	3500	3500	3500	3500	2900	3500	2900	3500	2900	2500	2900	2500	2900	2000	2500
RXV2	54.6-130.5																					2900
RXO3	108-240	3500	3500	3500	3500	3500	3500	3500	3500	3500	3500	3500	3500	2900	3500	2500	3500	2500	3500	2500	2900	3500
RXV3	i>240																					
RXO4	all	3500	3500	3500	3500	3500	3500	3500	3500	3500	3500	3500	3500	2900	3500	2900	3500	—				

n ₁ max (rpm)	ir	822		824		826		828		830		932		
		splash oil	forced lubric.	splash oil	forced lubric.	splash oil	forced lubric.	splash oil	forced lubric.	splash oil	forced lubric.	splash oil	forced lubric.	
RXO1	4.3-13.3	1500	2000	Valori su richiesta Ratings supplied on request Wertangaben auf Anfrage										
RXV1	13.4-28.6	1750	2500	—										
RXO2	19-54.6	2000	2500	2000	2500	Valori su richiesta Ratings supplied on request Wertangaben auf Anfrage								—
RXV2	54.6-130.5		2900		2900	—								
RXO3	108-240	2500	2900	2500	2900	2000	2500	Valori su richiesta Ratings supplied on request Wertangaben auf Anfrage						
RXV3	i>240						2900	—						

1.4 Verifiche

05 5) Verifica carichi radiali e assiali

RX 700 Series

Quando la trasmissione del moto avviene tramite meccanismi che generano carichi radiali sull'estremità

dell'albero, è necessario verificare che i valori risultanti non eccedano quelli indicati nelle tabelle delle prestazioni.

Come carico assiale ammissibile contemporaneo si ha:

$$F_{a1-2} = 0.2 \times F_{r1-2}$$

I carichi radiali indicati nelle tabelle si intendono applicati a metà della sporgenza dell'albero standard e sono riferiti ai riduttori operanti con fattore di servizio 1. Per le sporgenze fornite in alternativa, fare riferimento alla sporgenza standard.

Valori intermedi relativi a velocità non riportate possono essere ottenuti per interpolazione considerando però che F_{r1} a 500 min^{-1} e F_{r2} a 15 min^{-1} rappresentano i carichi massimi consentiti.

Per i carichi non agenti sulla mezzeria dell'albero lento o veloce si ha:

a 0.3 della sporgenza:

$$F_{rx} = 1.25 \times F_{r1-2}$$

a 0.8 dalla sporgenza:

$$F_{rx} = 0.8 \times F_{r1-2}$$

1.4 Verification

5) Overhung and thrust load verification

Should transmission movement determine radial loads on the angular shaft end, it is necessary to make sure that resulting values do not exceed the ones indicated in the tables.

Contemporary permissible axial load is given by the following formula:

$$F_{a1-2} = 0.2 \times F_{r1-2}$$

The radial loads shown in the tables are applied on the centre line of the standard shaft extension and are related to gearboxes working with service factor 1. With reference to alternative values of shaft extension, refer to standard shaft extension.

Intermediate values of speeds that are not listed can be obtained through interpolation but it must be considered that F_{r1} at 500 min^{-1} and F_{r2} at 15 min^{-1} represent the maximum allowable loads.

For loads which are not applied on the centre line of the output or input shaft, following values will be obtained:

at 0.3 from extension:

$$F_{rx} = 1.25 \times F_{r1-2}$$

at 0.8 from extension:

$$F_{rx} = 0.8 \times F_{r1-2}$$

1.4 Überprüfungen

5) Überprüfung der Radial- und Axialkräfte

Wird das Wellenende auch durch Radialkräfte belastet, so muß sichergestellt werden, daß die resultierenden Werte die in der Tabelle angegebenen nicht überschreiten.

Die Axialbelastung beträgt dann:

$$F_{a1-2} = 0.2 \times F_{r1-2}$$

Bei den in der Tabelle angegebenen Radialbelastungen wird eine Krafteinwirkung auf die Mitte des Wellenendes zugrunde gelegt; außerdem arbeiten die Getriebe mit Betriebsfaktor 1. Bei Einsatz von Sonderabtriebswellen beziehen Sie sich bitte auf die oben aufgeführten Abstände der Standardabtriebswellen.

Zwischenwerte für nicht aufgeführte Drehzahlen können durch Interpolation ermittelt werden. Hierbei ist jedoch zu berücksichtigen, daß der maximale Wert für F_{r1} bei 500 min^{-1} und für F_{r2} bei 15 min^{-1} gilt.

Bei Lasten, die nicht auf die Mitte der Ab- und Antriebswellen wirken, legt man folgende Werte zugrunde:

0.3 vom Wellenabsatz entfernt:

$$F_{rx} = 1.25 \times F_{r1-2}$$

0.8 vom Wellenabsatz entfernt:

$$F_{rx} = 0.8 \times F_{r1-2}$$

1.4 Verifiche

1.4 Verification

1.4 Überprüfungen

RX 700 Series

Calcolo Fr

Per calcolare il carico Fr agente sull'albero veloce o lento diamo formule approssimate per alcune trasmissioni più comuni, per la determinazione del carico radiale su albero veloce o lento.

Fr calculation

Use the formula and the approximate factors for input or output overhung load determination referred to the most common drive members to calculate Fr load at output shaft.

Berechnung der Fr

Für die Berechnung der an der Abtriebswelle oder Antriebswelle wirkenden Belastungen Fr geben wir approximative Formeln an, die für einige der allgemeinen Antriebsformen zum Bestimmen der auf die An- oder Abtriebswelle einwirkenden Radialkraft verwendet werden kann.

$Fr = k \cdot \frac{T}{d}$	Fr [N] Carico radiale approssimato Approximate overhung load Approx. Wert - Radialkraft	d [mm] Diametro pulegge, ruote Pulley diameter, wheels Durchmesser Räder, Riemenscheiben	k Fattore di collegamento Connection factor Anschlusswert	T [Nm] Momento torcente Torque Drehmoment	
k =	7000	5000	3000	2120	2000
Trasmissioni Drive member Antriebe	Ruote di frizione (gomma su metallo) Friction wheel drive (rubber on metal) Kupplungsräder (Gummi auf Metall)	Cinghie trapezoidali V belt drives Keilriemen	Cinghie dentate Toothed belts Zahnriemen	Ingranaggi cilindrici Spur gears Zylinderzahnräder	Catene Chain drives Ketten

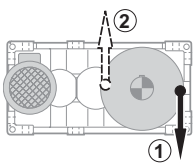

Nel caso di sollevamento con tamburo con tiro verso il basso è preferibile che la fune si avvolga dalla parte opposta al motore (1).
Nel caso più gravoso del precedente, con tiro verso l'alto, viceversa è preferibile che la fune si avvolga dal lato motore (2).

In lifting applications using winch drums in a downward pull direction, it is best for the rope to wrap on the side opposite to the motor (1).
In the more severe case of upward pull direction, the rope should wrap on motor side (2).

Bei Hebeverfahren mit einer Trommel mit Zugkraft nach unten sollte das Seil auf der dem Motor (1) entgegen gesetzten Seite aufgerollt werden.
Im Fall eines härteren Einsatzes als den zuvor genannten, mit Zugkraft nach oben, sollte das Seil dagegen an der Motorseite (2) aufgewickelt werden.

Verifiche

Verification

Überprüfungen

Caso A)
Per carichi radiali minori di 0.25 Fr₁' o Fr₂' è necessario verificare soltanto che contemporaneamente al carico radiale sia presente un carico assiale non superiore a 0.2 volte Fr₁' o Fr₂';
Caso B)
Per carichi radiali maggiori di 0.25 Fr₁' o Fr₂';
1) Calcolo abbreviato: Fr(input) < Fr₁' e Fr (output) < Fr₂' e che contemporaneamente al carico radiale sia presente un carico assiale non superiore a 0.2 volte Fr₁' o Fr₂';
2) Calcolo completo per il quale occorre fornire i seguenti dati:
- momento torcente applicato o potenza applicata
- n₁ e n₂ (giri al minuto dell'albero veloce e dell'albero lento)
- carico radiale Fr (direzione, intensità, verso)
- senso di rotazione dell'albero
- grandezza e tipo del riduttore scelto
- tipo olio impiegato e sua viscosità
- esecuzione grafica assi:
- carico assiale presente Fa
Consultare il supporto Tecnico per la verifica.

Case A)
For overhung loads lower than 0.25 Fr₁' or Fr₂', ensure that the thrust load applied simultaneously with OHL is not greater than 0.2 times Fr₁' or Fr₂';
Case B)
For overhung loads greater than 0.25 Fr₁' or Fr₂';
1) Quick calculation method: Fr(input) < Fr₁' and Fr (output) < Fr₂' and thrust load applied simultaneously with OHL not greater than 0.2 times Fr₁' or Fr₂';
2) For the standard calculation method, the following information is required:
- applied torque or power
- n₁ and n₂ (input and output shaft min⁻¹)
- overhung load Fr (orientation, amount of loading, direction)
- size and type of selected gear unit
- oil type and viscosity
- shaft arrangement:
- actual thrust load Fa
Please contact our Engineering for a verification.

Fall A)
Bei Radialkräften unter 0.25 Fr₁' oder Fr₂' muss nur überprüft werden, dass gleichzeitig mit der Belastung durch die Radialkraft auch eine Axialkraft von nicht mehr als 0,2 Mal Fr₁' oder Fr₂' vorliegt.
Fall B)
Bei Radialkräften über 0.25 Fr₁' oder Fr₂':
1) Verkürzte Berechnungsgleichung: Fr(input) < Fr₁' und Fr (output) < Fr₂' und dass gleichzeitig mit der Belastung durch die Radialkraft auch eine Axialkraft von nicht mehr als 0.2 Mal Fr₁' oder Fr₂' vorliegt.
2) Vollständige Berechnungsgleichung für die folgende Daten erforderlich sind:
- appliziertes Drehmoment oder applizierte Leistung
- n₁ und n₂ (Drehungen/Minute der Antriebs- und Abtriebswelle)
- Radialkraft Fr (Richtung, Intensität, Seite)
- Drehrichtung der Welle
- Baugröße und Typ des gewählten Getriebes
- verwendeter Öltyp und dessen Viskositätsgrad
- grafische Achsenausführung
- vorliegende Axialkraft Fa
Für eine Überprüfung die Technischen Unterlagen konsultieren.

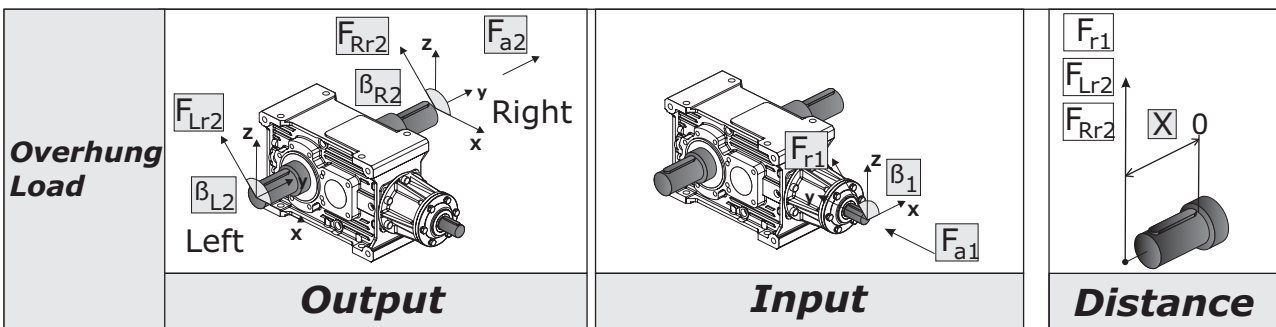
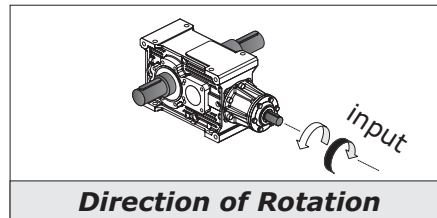
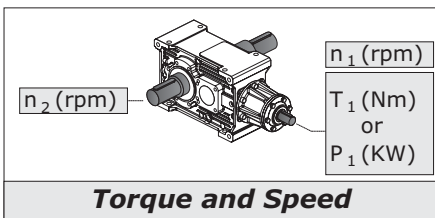

1.4 Verifiche

05 5) Verifica carichi radiali e assiali

RX 800 Series

Qualora il collegamento tra riduttore e macchina motrice o operatrice sia effettuato con mezzi che generano carichi radiali sull'estremità d'albero veloce o lento, occorre fare le seguenti verifiche.

Calcolo Fr_2' e Fr_1'

I carichi massimi Fr_1 e Fr_2 sono calcolati con $F_s=1$ ed a una distanza dalla battuta dell'albero di 0.5 S se albero veloce o 0.5 R se albero lento.

Tali valori sono riportati nelle tabelle delle prestazioni; per esecuzione Fn vedere sezione T.

Per distanze variabili tra 0 e una distanza "X" bisogna utilizzare le tabelle seguenti:
 Fr_2 con coefficiente A.
 Fr_2 con coefficiente C nel caso di flange FD.
 Fr_1 con coefficiente B.

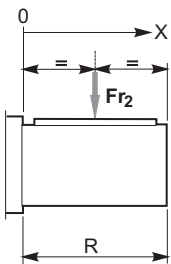

$$Fr_2' = Fr_2 \cdot \left(\frac{A}{A + X - \frac{R}{2}} \right)$$

$$Fr_2' = Fr_2 \cdot C$$

solo per esecuzione FD
only for FD configuration
Nur für Ausführungen FD

A - C

Coefficienti correttivi del carico radiale di catalogo in uscita Fr_2 in funzione della distanza dalla battuta
 Load location factors to adjust output OHL capacity rating Fr_2 based on distance from shoulder
 Korrekturkoeffizient der Radialkraft am Abtrieb Fr_2 gemäß Katalog in Abhängigkeit des Ansatzabstands

		RXO															
		802	804	806	808	810	812	814	816	818	820	822	824	826	828	830	832
A		99	109	124	137	156	175	200	225	236	261	294	331	385	405	447	507
C		1.32	1.35	1.39	1.46	1.49	1.43	1.32	1.32	1.33	1.35	1.32	—				

Fr₂' [N]	Carico radiale ammissibile su albero uscita alla distanza X	Permissible output shaft OHL at distance X	An Abtriebswelle auf Distanz X zulässige Radialkraft
Fr₂ [N]	Carico radiale ammissibile su albero uscita indicato a catalogo	Output shaft OHL capacity as per catalogue rating	An Abtriebswelle gemäß Katalogangaben zulässige Radialkraft
X [mm]	Distanza dalla battuta dell'albero	Distance from shaft shoulder	Distanz vom Wellenansatz
R [mm]	Sporgenza dell'albero uscita	Output shaft projection	Überstand der Abtriebswelle
A	Coefficiente da tabella	Load location factor from table	Koeffizient aus Tabelle
C	Coefficiente da tabella	Load location factor from table	

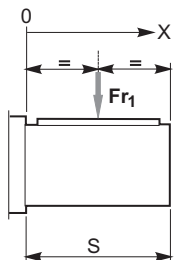

$$Fr_1' = Fr_1 \cdot \left(\frac{B}{B + X - \frac{S}{2}} \right)$$

B

Coefficienti correttivi del carico radiale di catalogo in entrata Fr_1 in funzione della distanza dalla battuta
 Load location factors to adjust input OHL capacity rating Fr_1 based on distance from shoulder
 Korrekturkoeffizient der Radialkraft am Antrieb Fr_1 gemäß Katalog in Abhängigkeit des Ansatzabstands

		Size	802	804	806	808	810	812	814	816	818	820	822	824	826	828	830	832
B	RXO1	67	75	82	90	100	109	120	133	147	164	184	205	—				
	RXO2	53	61	67	75	82	90	100	109	120	133	147	164	184	205	—		
	RXO3	47	48	53	61	67	75	82	90	100	109	120	133	147	164	184	205	
	RXO4	32	42	47	48	53	61	67	75	—								

Fr₁' [N]	Carico radiale ammissibile su albero entrata alla distanza X	Permissible input shaft OHL at distance X	An Abtriebswelle auf Distanz X zulässige Radialkraft
Fr₁ [N]	Carico radiale ammissibile su albero entrata indicato a catalogo	Input shaft OHL capacity as per catalogue rating	An Abtriebswelle gemäß Katalogangaben zulässige Radialkraft
X [mm]	Distanza dalla battuta dell'albero	Distance from shaft shoulder	Distanz vom Wellenansatz
S [mm]	Sporgenza dell'albero entrata	Input shaft projection	Überstand der Abtriebswelle
B	Coefficiente da tabella	Load location factor from table	Koeffizient aus Tabelle

1.4 Überprüfungen

5) Überprüfung der Radial- und Axialkräfte

Erfolgt die Verbindung zwischen Getriebe und Kraft- oder Arbeitsmaschine mit Vorrichtungen, die Radialkräfte auf das Ende der Antriebs- oder Abtriebswelle ausüben, sind folgende Überprüfungen erforderlich.

Berechnung von Fr_2' e Fr_1'

Die maximalen Belastungskräfte Fr_1 und Fr_2 werden mit $F_s=1$ und auf einem Abstand vom Wellenansatz von 0.5 S im Fall der Antriebswelle oder 0.5 R im Fall der Abtriebswelle berechnet.

Diese Werte werden in den Leistungstabellen angegeben; die Werte von Ausführung Fn, können Sie auf Abschnitt T finden.

Bei zwischen 0 und einer Distanz "X" variierenden Abständen müssen folgende Tabellen verwendet werden:

Fr_2 mit Koeffizient A.
 Fr_2 mit Koeffizient C bei FD-Flanschen.
 Fr_1 mit Koeffizient B.

1.4 Verifiche

1.4 Verification

1.4 Überprüfungen

RX 800 Series

Calcolo Fr

Per calcolare il carico Fr agente sull'albero veloce o lento diamo formule approssimate per alcune trasmissioni più comuni, per la determinazione del carico radiale su albero veloce o lento.

Fr calculation

Use the formula and the approximate factors for input or output overhung load determination referred to the most common drive members to calculate Fr load at output shaft.

Berechnung der Fr

Für die Berechnung der an der Abtriebswelle oder Antriebswelle wirkenden Belastungen Fr geben wir approximative Formeln an, die für einige der allgemeinen Antriebsformen zum Bestimmen der auf die An- oder Abtriebswelle einwirkenden Radialkraft verwendet werden kann.

$Fr = k \cdot \frac{T}{d}$	Fr [N] Carico radiale approssimato Approximate overhung load Approx. Wert - Radialkraft	d [mm] Diametro pulegge, ruote Pulley diameter, wheels Durchmesser Räder, Riemenscheiben	k Fattore di collegamento Connection factor Anschlusswert	T [Nm] Momento torcente Torque Drehmoment	
k =	7000	5000	3000	2120	2000
Trasmissioni Drive member Antriebe	Ruote di frizione (gomma su metallo) Friction wheel drive (rubber on metal) Kupplungsräder (Gummi auf Metall)	Cinghie trapezoidali V belt drives Keilriemen	Cinghie dentate Toothed belts Zahnriemen	Ingranaggi cilindrici Spur gears Zylinderzahnräder	Catene Chain drives Ketten

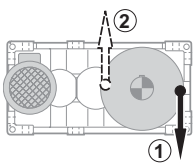

Nel caso di sollevamento con tamburo con tiro verso il basso è preferibile che la fune si avvolga dalla parte opposta al motore (1).
Nel caso più gravoso del precedente, con tiro verso l'alto, viceversa è preferibile che la fune si avvolga dal lato motore (2).

In lifting applications using winch drums in a downward pull direction, it is best for the rope to wrap on the side opposite to the motor (1).
In the more severe case of upward pull direction, the rope should wrap on motor side (2).

Bei Hebeverfahren mit einer Trommel mit Zugkraft nach unten sollte das Seil auf der dem Motor (1) entgegen gesetzten Seite aufgerollt werden.
Im Fall eines härteren Einsatzes als den zuvor genannten, mit Zugkraft nach oben, sollte das Seil dagegen an der Motorseite (2) aufgewickelt werden.

Verifiche

Verification

Überprüfungen

Caso A)
Per carichi radiali minori di 0.25 Fr₁' o Fr₂' è necessario verificare soltanto che contemporaneamente al carico radiale sia presente un carico assiale non superiore a 0.2 volte Fr₁' o Fr₂';
Caso B)
Per carichi radiali maggiori di 0.25 Fr₁' o Fr₂';
1) Calcolo abbreviato: Fr(input) < Fr₁' e Fr (output) < Fr₂' e che contemporaneamente al carico radiale sia presente un carico assiale non superiore a 0.2 volte Fr₁' o Fr₂';
2) Calcolo completo per il quale occorre fornire i seguenti dati:
- momento torcente applicato o potenza applicata
- n₁ e n₂ (giri al minuto dell'albero veloce e dell'albero lento)
- carico radiale Fr (direzione, intensità, verso)
- senso di rotazione dell'albero
- grandezza e tipo del riduttore scelto
- tipo olio impiegato e sua viscosità
- esecuzione grafica assi:
- carico assiale presente Fa
Consultare il supporto Tecnico per la verifica.

Case A)
For overhung loads lower than 0.25 Fr₁' or Fr₂', ensure that the thrust load applied simultaneously with OHL is not greater than 0.2 times Fr₁' or Fr₂';
Case B)
For overhung loads greater than 0.25 Fr₁' or Fr₂';
1) Quick calculation method: Fr(input) < Fr₁' and Fr (output) < Fr₂' and thrust load applied simultaneously with OHL not greater than 0.2 times Fr₁' or Fr₂';
2) For the standard calculation method, the following information is required:
- applied torque or power
- n₁ and n₂ (input and output shaft min⁻¹)
- overhung load Fr (orientation, amount of loading, direction)
- size and type of selected gear unit
- oil type and viscosity
- shaft arrangement:
- actual thrust load Fa
Please contact our Engineering for a verification.

Fall A)
Bei Radialkräften unter 0.25 Fr₁' oder Fr₂' muss nur überprüft werden, dass gleichzeitig mit der Belastung durch die Radialkraft auch eine Axialkraft von nicht mehr als 0,2 Mal Fr₁' oder Fr₂' vorliegt.
Fall B)
Bei Radialkräften über 0.25 Fr₁' oder Fr₂':
1) Verkürzte Berechnungsgleichung: Fr(input) < Fr₁' und Fr (output) < Fr₂' und dass gleichzeitig mit der Belastung durch die Radialkraft auch eine Axialkraft von nicht mehr als 0.2 Mal Fr₁' oder Fr₂' vorliegt.
2) Vollständige Berechnungsgleichung für die folgende Daten erforderlich sind:
- appliziertes Drehmoment oder applizierte Leistung
- n₁ und n₂ (Drehungen/Minute der Antriebs- und Abtriebswelle)
- Radialkraft Fr (Richtung, Intensität, Seite)
- Drehrichtung der Welle
- Baugröße und Typ des gewählten Getriebes
- verwendeter Öltyp und dessen Viskositätsgrad
- grafische Achsenausführung
- vorliegende Axialkraft Fa
Für eine Überprüfung die Technischen Unterlagen konsultieren.

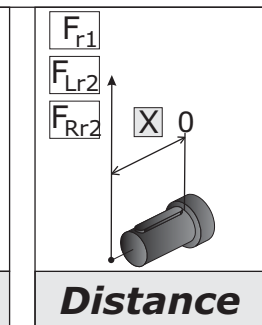
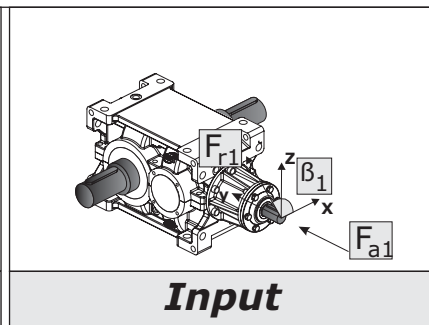
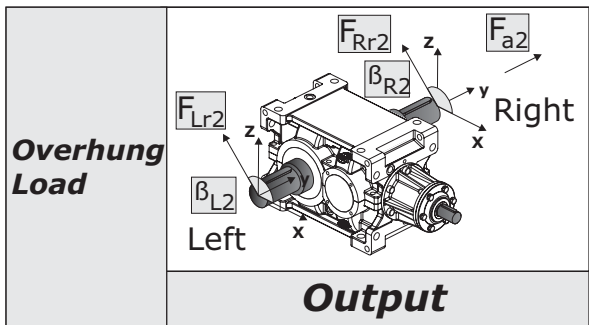
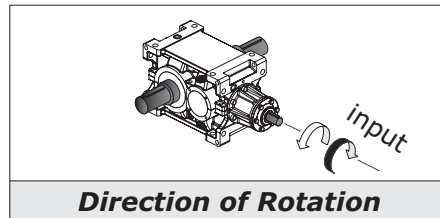
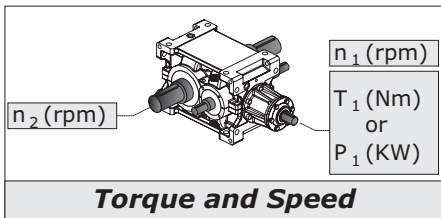

1.4 Verifiche

06 6) Verifica Posizione di montaggio

07 7) Adeguatezza della potenza termica del riduttore:

Nel caso di solo riduttore in servizio continuo o intermittente gravoso in ambienti a temperatura elevata e/o con difficoltà di scambio termico (es. acciaierie) è necessario verificare che la potenza termica nominale corretta dai fattori sia superiore alla potenza assorbita come evidenziato nella seguente equazione:

1.4 Verification

6) Check mounting position

7) Ensure gear unit thermal power is suitable for the application:

If a gear unit is to be used in continuous or intermittent duty in environments where high temperatures and/or poor heat exchange are encountered (such as steelworks), check to ensure the thermal power obtained after application of the relevant correction factors is greater than absorbed power, i.e. that the following condition is verified:

1.4 Überprüfungen

6) Prüfen der Einbaulage

7) Angemessene thermische Grenzleistung des Getriebes:

Wird ein einziges Getriebe im Dauerbetrieb oder harten Schaltbetrieb in einer Umgebung mit hohen Temperaturen und/oder einem schwierigem Wärmeaustausch (z.B. Stahlwerke) eingesetzt, muss geprüft werden, dass die thermische, von den jeweiligen Faktoren korrigierte Nenngrenzleistung über der Aufnahmeleistung liegt, wie es in der folgenden Gleichung dargestellt wird:

$$P_1 \leq P_{IN} \cdot fm \cdot fa \cdot fd \cdot fp \cdot ff \quad [kW]$$

Dove:

P_{IN} = potenza termica nominale
 fm = fattore correttivo per la posizione di montaggio
 fa = fattore correttivo dell'altitudine
 fd = fattore correttivo del tempo di lavoro
 fp = fattore correttivo della temperatura ambiente
 ff = fattore correttivo di aerazione con ventola

Where:

P_{ta} = thermal power rating
 fm = mounting position factor
 fa = altitude factor
 fd = operation time factor
 fp = ambient temperature factor
 ff = fan cooling factor

Hier ist:

P_{ta} = termische Nenngrenzleistung
 fm = Korrekturfaktor für Einbaulage
 fa = Höhenkorrekturwert
 fd = Korrekturfaktor der Arbeitszeit
 fp = Korrekturfaktor der Umgebungstemperatur
 ff = Korrekturfaktor der Belüftung durch Lüfter

RX 700 - Qualora tale condizione non sia verificata occorre consultarci.

RX 700 - In case such operation condition is not verified please get in touch with us.

RX 700 - Wenn diese Bedingung nicht erfüllt wird, bitten wir Sie sich an uns zu wenden.

RX 800 - Qualora tale condizione non sia verificata occorre sostituire la ventola con un gruppo di raffreddamento con scambiatore di calore. Per selezionare il gruppo di raffreddamento adeguato occorre determinare la P_{ta} necessaria:

RX 800 - If this condition is not verified, opt for a heat exchanger instead of fan cooling. To select a suitable cooling unit, you need to determine required P_{ta} :

RX 800 - Sollte diese Bedingung nicht gegeben sein, muss der Lüfter durch ein Kühlaggregat mit Wärmeaustauscher ersetzt werden. Vor der Wahl des angemessenen Kühlaggregats muss zunächst die erforderliche P_{ta} bestimmt werden:

RX 700 Series
 $P_{ta} = 0$

$$P_{ta} \geq P_1 - (P_{IN} \cdot fm \cdot fa \cdot fd \cdot fp) \quad [kW]$$

dove:

P_{ta} = potenza termica addizionale

Dopo avere selezionato il gruppo di raffreddamento, ripetere la verifica aggiungendo alla precedente il valore massimo di P_{tamax} del range identificato espresso in tabella, adeguato con i coefficienti correttivi di temperatura acqua e aria:

Where:

P_{ta} = additional thermal power required

After selecting the cooling unit, check that the following condition is satisfied; as you can see, it considers the upper limit value P_{tamax} of the resulting tabulated range adjusted using the water and air temperature correction factors:

Hier ist:

P_{ta} = termische Zusatzgrenzleistung

Nach erfolgter Wahl der Kühlgruppe, die Kontrolle wiederholen und dabei dem vorausgehenden Wert den max. Wert des P_{tamax} des in der Tabelle angegebenen Bereichs zurechnen und durch die Korrekturkoeffizienten der Wasser- und Lufttemperatur anpassen:

RX 700 Series
 $P_{tmax} = 0$

$$P_1 \leq (P_{IN} \cdot fm \cdot fa \cdot fd \cdot fp) + (P_{tamax} \cdot fw \cdot fc) \quad [kW]$$

dove:

P_{tamax} = potenza termica addizionale del range identificato espresso in tabella
 fw = coefficiente relativo alla temperatura dell'acqua (esclude fc)
 fc = coefficiente relativo alla temperatura dell'aria (esclude fw)

Where:

P_{tamax} = additional thermal power required obtained from resulting tabulated range
 fw = water temperature factor (excludes fc)
 fc = air temperature factor (excludes fw)

Hier ist:

P_{tamax} = thermische Zusatzgrenzleistung des identifizierten, in der Tabelle angegebenen Bereichs
 fw = Koeffizient bezüglich der Wassertemperatur (schließt fc aus)
 fc = Koeffizient bezüglich der Lufttemperatur (schließt fw aus)

1.4 Verifiche

1.4 Verification

1.4 Überprüfungen

P_{tN}

Potenza termica nominale
Thermal power rating
Termische Nenngrenzleistung

	RX 700 Series					RX 800 Series															
	704	708	712	716	720	802	804	806	808	810	812	814	816	818	820	822	824	826	828	830	832
RXO1	7.5	11.0	16.5	25	39	30	39	51	66	82	104	127	158	203	252	304	368	—	—	—	—
RXO2	—	12	18	26	35	24	30	40	52	65	82	102	127	165	205	248	306	368	445	—	—
RXO3	—	—	—	—	—	14	17	23	30	38	49	61	77	101	127	156	195	235	289	365	440
RXO4	—	—	—	—	—	11	14	18	22	28	35	45	55	—	—	—	—	—	—	—	—

La P_{tN} è riferita ad un ambiente industriale aperto con velocità dell'aria di 1,4 m/s; nel caso di ambienti confinati scarsamente aerati consultarci

P_{tN} refers to an open space industrial environment with air speed 1,4 m/s; in the event of a confined space environment with poor ventilation, please contact the factory

Die P_{tN} bezieht sich immer auf einen Einsatz im industriellen offenen Umfeld mit Luftgeschwindigkeit 1,4 m/s; sollten Umgebungen mit geringer Belüftung daran angrenzen, bitten wir Sie, sich mit uns in Verbindung zu setzen

f_m

Fattore correttivo per la posizione di montaggio, velocità e rapporto
Correction factor accounting for mounting position, speed and ratio
Korrekturfaktor für Einbaulage, Drehzahl und Übersetzungsverhältnis

f_m	RX 700 Series
	1.0

f_m	ir	RX 800 Series									
		all	M1-M2-M6	M3-M5			M4				
		n_1									
RXO1 RXV1	802-806	1	1	0-749	0- n_{1max}	750-1250	1251-1750	1751- n_{1max}	750-1250	1251-1750	1751- n_{1max}
				1	1	1	1	1	1		
	808-814			0.9	0.8	0.65	1	0.9	0.7		
				0.95	0.85	0.7	1	1	0.8		
	816-824			0.7	0.65	0.5	0.9	0.8	0.65		
				0.9	0.75	0.65	0.95	0.85	0.75		

f_m	ir	RX 800 Series									
		all	M1-M2	M3-M6			M4-M5				
		n_1									
RXO2 RXV2	802-806	1	1	0-749	0- n_{1max}	750-1250	1251-1750	1751- n_{1max}	750-1250	1251-1750	1751- n_{1max}
				1	1	1	1	1	1		
	808-814			0.95	0.85	0.7	0.85	0.75	0.6		
				1	0.9	0.75	0.9	0.8	0.65		
	816-820			0.85	0.75	0.6	0.7	0.65	0.5		
				0.9	0.8	0.65	0.75	0.7	0.55		
822-828	0.75	0.7	0.55	0.7	0.6	0.5					
	0.85	0.75	0.6	0.7	0.65	0.5					

f_m	ir	RX 800 Series									
		all	M1-M2	M3-M6			M4-M5				
		n_1									
RXO3 RXV3	802-806	1	1	0-749	0- n_{1max}	750-1250	1251-1750	1751- n_{1max}	750-1250	1251-1750	1751- n_{1max}
				1	1	1	1	1	1		
	808-814			0.95	0.85	0.7	0.9	0.8	0.65		
				1	1	0.8	1	0.9	0.75		
	816-820			0.9	0.8	0.65	0.85	0.75	0.6		
				1	0.9	0.75	0.95	0.85	0.7		
822-832	0.85	0.75	0.6	0.75	0.7	0.55					
	0.95	0.85	0.7	0.9	0.8	0.65					
RXO4	802-806	all	1	1	1	1	1	1	1	1	
	808-816				1	1	0.8	1	0.9	0.75	

N.B.
I valori di n_{1max} sono riportati al punto 4

NOTE:
 n_{1max} values are listed at point 4

HINWEIS:
Die Werte n_{1max} werden unter Punkt 4 angegeben.
 $f_m=1$ - / falls n_1 eine Zwangsschmierung erfordert

$f_m=1$ - nel caso in cui n_1 richieda la lubrificazione forzata

1.4 Verifiche

1.4 Verification

1.4 Überprüfungen

fa

Fattore correttivo dell'altitudine
Altitude factor
Korrekturwert der Höhe

m	0	750	1500	2250	3000
fa	1	0.95	0.90	0.85	0.81

fd

Fattore correttivo del tempo di lavoro
Operation time factor
Korrekturwert der Betriebszeit

S3%	100	80	60	40	20
fd	1	1.05	1.15	1.35	1.8

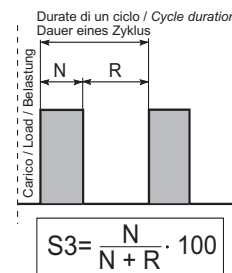

fp

Fattore correttivo della temperatura ambiente
Ambient temperature factor
Korrekturfaktor der Umgebungstemperatur

Temperatura ambiente Ambient temperature Umgebungstemperatur	50 °C	40 °C	30 °C	20 °C	10 °C	0 °C
fp	0.63	0.75	0.87	1	1.12	1.25

ff

Fattore di aerazione
Aeration factor
Belüftungsfaktor

RX 700 Series

ff	1	Riduttore senza ventilazione forzata / Non ventilated gearbox / Nicht belüftetes Getriebe
-----------	---	---

Il fattore correttivo ff della potenza termica che tiene conto dell'effetto refrigerante della ventola assume in accordo con le norme AGMA 6010.E88 i valori riportati nella tabella. L'impiego è limitato alle velocità maggiori o uguali a 700 min⁻¹.

Cooling fan factors ff reported in table 8 are in accordance with AGMA 6010.E88 and can be used directly to adjust thermal power to reflect the use of a cooling fan. These factors must only be used for speeds equal to 700 rpm and higher.

In Übereinstimmung mit den Normen AGMA 6010.E88 nimmt der Korrekturwert ff der thermischen Grenzleistung, der den Kühleffekt des Lüfters berücksichtigt, die in der Tabelle angegebenen Werte an. Der Einsatz beschränkt sich auf die Drehzahlen die 700 min⁻¹ betragen oder darüber liegen.

RX 800 Series

ff	Tipo Type Typ	Tipo ventola Fan type Lüfertyp	Note Notes Hinweise
1.7	RXO RXV	VE	—
2.1	RXO	VEMB VEMN	—

1.4 Verifiche

1.4 Verification

1.4 Überprüfungen

Pta [kW]

Potenza termica addizionale
Additional thermal power
Thermische Zusatzgrenzleistung

Raffreddamento con scambiatore acqua-olio (Tacqua=15°C)
Cooling by water-oil exchanger (Twater=15°C)
Kühlung durch Wasser-/Ölaustauscher (TWasser=15°C)

RFW...		RXO-V 1	RXO-V 2	RXO-V 3
Size	Q _{min}			
1	6	≤ 66	≤ 46	≤ 37
2	6	67 ÷ 108	47 ÷ 74	38 ÷ 59
3	16	109 ÷ 202	75 ÷ 139	60 ÷ 111
4	30	203 ÷ 542	140 ÷ 373	112 ÷ 298
5	80	543 ÷ 968	374 ÷ 666	299 ÷ 533

Raffreddamento con scambiatore aria-olio (Taria=20°C)
Cooling by air-oil exchanger (Tair=20°C)
Kühlung durch Luft-/Ölaustauscher (TLuft=20°C)

RFA...		RXO-V 1	RXO-V 2	RXO-V 3
Size	Q _{min}			
1	6	≤ 149	≤ 103	≤ 82
2	13	150 ÷ 200	104 ÷ 138	83 ÷ 110
3-A 3-B	32	201 ÷ 392	139 ÷ 269	111 ÷ 215
4	112	393 ÷ 656	270 ÷ 451	216 ÷ 361
5	112	657 ÷ 984	452 ÷ 676	362 ÷ 541
6	160	985 ÷ 1235	677 ÷ 849	452 ÷ 679
7	160	1236 ÷ 1940	850 ÷ 1334	680 ÷ 1067

fw

Coefficiente relativo alla temperatura dell'acqua
Water temperature factor
Koeffizient bezüglich der Wassertemperatur

Twater	15°C	20° C	25° C	30° C
fw	1	0.85	0.7	0.6



fc

Coefficiente relativo alla temperatura dell'aria
Air temperature factor
Koeffizient bezüglich der Lufttemperatur

Tair	15° C	20° C	25° C	30° C	35° C	40° C
fc	1.12	1	0.88	0.75	0.65	0.5

Una volta selezionato lo scambiatore è necessario verificare se la quantità di olio del riduttore è sufficiente a garantire un corretto funzionamento del gruppo. Pertanto deve essere verificata la relazione:

After selecting the cooling system it's necessary to check if the oil quantity is enough for making it work.

Nach der Auswahl des Kühlsystems ist es nötig mit unten stehender Formel zu überprüfen, ob die Ölmenge für diese Arbeit ausreichend ist:

Therefore check the following formula:

$$Q_{rid} \geq Q_{min} \times 1.2$$

Q_{rid} - Quantità olio di riempimento del riduttore (vedere 1.8)

Q_{rid} - Gearbox oil quantity (l) look at points 1.8

Q_{rid} - Ölfüllmenge des Getriebes siehe Punkt 1.8

Q_{min} - Quantità olio minima che deve avere il serbatoio olio per garantire il funzionamento del gruppo.

Q_{min} - Minimum tank oil quantity to assure the cooling running.

Q_{min} - Minimale Ölfüllung im Tank, um die Kühlung sicherzustellen.

Qualora la relazione non fosse soddisfatta è necessario prevedere un serbatoio aggiuntivo

If the formula is not satisfied, it will be necessary to add another oil tank.

Sollte die Relation nicht zufriedenstellend sein, muss ein Zusatztank vorgesehen werden.

1.4 Verifiche

1.4 Verification

1.4 Überprüfungen

08 8) Compatibilità esecuzione grafica e forma costruttiva.

8) *Ensure that shaft arrangement and design configuration are compatible.*

8) Kompatibilität der grafischen Ausführung und der Bauform.

Per ulteriori informazioni vedere - 1.7.

For more details, please read - 1.7

Sie können Weitere Informationen siehe - 1.7.

09 9) Condizioni di impiego:
9.1 - $t_a > 0\text{ °C}$: vedere i punti 1.8;
9.2 - $t_a < -10\text{ °C}$: contattare il nostro servizio tecnico-commerciale.

9) *Using conditions:*
9.1 - $t_a > 0\text{ °C}$: *look at points 1.8;*
9.2 - $t_a < -10\text{ °C}$: *contact our technical sales dept.*

9) Anwendungsbedingungen:
9.1 - $t_a > 0\text{ °C}$: siehe Punkt 1.8;
9.2 - $t_a < -10\text{ °C}$: bitte kontaktieren sie unsere technische Verkaufsabteilung.

10 10) Coppia di slittamento del calettatore

10) *Shrink disk slipping torque*

10) Schrumpfscheiben-Schlupfmoment

E' necessario che sia soddisfatta la seguente relazione:

The following formula must be satisfied:

Folgende Bedingung muss erfüllt sein:

$$M_{2s} > T_{2max}$$

Coppia Slittamento Slipping torques Rutsch- momente M_{2s} [kNm]	RX 700 Series					RX 800 Series														
	704	708	712	716	720	802	804	806	808	810	812	814	816	818	820	822	824	826	828	830
	0.34	0.78	1.52	2.5	8.3	4.6	8.3	12.0	20.2	23.0	31.7	42.3	61.5	86.0	138	240	320	415	612	788

T_{2max} - Coppia Uscita Sovraccarico Applicazione

T_{2max} - *Application overloaded output torque*

T_{2max} - Maximalmoment bei Überlast

M_{2s} - Coppia di slittamento calettatore

M_{2s} - *Shrink disc slipping torque:*

M_{2s} - Schrumpfscheiben-Schlupfmoment:

11 11) Coppie antiretro

11) *Back-stop device torque*

11) Rücklauf-Drehmomente

E' necessario che sia soddisfatta la seguente relazione:

The following ratio must be met:

Folgendes Verhältnis muss gegeben sein

$$T_{1a} > \left(\frac{T2r * 100}{RD * ir} \right)$$

RX 700 Series	RXO-V1														
704	ir			9.5	13.8	15.2	18.5	22.1	26.5	36.4	44.3	55.2	63.5		
	T1a			16.7	11.5	16.7	16.7	11.5	11.5	7	7	4.9	4.9		
708	ir	5.2	7.1	10.0	11.9	14.6	16.7	21.2	24.2	31.0	39.8	51.0	57.0	73.2	
	T1a	26.1	26.1	26.1	26.1	26.1	26.1	18.0	18.0	18.0	10.9	10.9	7.6	7.6	
712	ir	5.2	7.4	10.0	12.2	14.6	17.0	21.2	24.6	31.0	40.5	51.0	58.0	73.2	
	T1a	70.0	70.0	70.0	70.0	70.0	70.0	48.3	48.3	48.3	29.4	29.4	20.5	20.5	
716	ir	5.2	7.4	10.2	12.2	14.6	17.0	21.2	24.6	31.9	40.5	52.6	58.0	75.4	
	T1a	131.5	131.5	131.5	131.5	131.5	131.5	90.7	90.7	90.7	55.1	55.1	38.4	38.4	
720	ir	5.2	7.6	10.3	12.3	14.9		20.2	24.6	33.4	40.7	51.3	57.4	72.3	
	T1a	217.8	217.8	217.8	217.8	217.8		132.2	132.2	80.0	80.0	80.0	56.7	56.7	

1.4 Verifiche

1.4 Verification

1.4 Überprüfungen

RX 700 Series		RXO-V2														
708	ir	A richiesta / On request / Auf Anfrage														
	T _{1a}															
712	ir	60.8	74.5	98.4	125.2	142.6	168.1	202.5	234.7	259.9	296.1	304.1	372.7	424.6	571.0	
	T _{1a}	26.1	26.1	26.1	18.0	18.0	10.9	10.9	10.9	10.9	10.9	7.6	7.6	7.6	7.6	
716	ir	61.9	74.5	100.1	125.2	145.0	177.7	206.0	238.7	267.6	310.2	342.3	383.8	444.8	561.2	
	T _{1a}	70.0	70.0	70.0	48.3	48.3	29.4	29.4	29.4	29.4	29.4	20.5	20.5	20.5	20.5	
720	ir		46.0	54.9	66.9	79.5	102.5	125.0	159.5	205.7	250.5	315.6	371.6	452.5	569.4	
	T _{1a}		131.5	131.5	131.5	90.7	90.7	90.7	55.1	55.1	55.1	55.1	38.4	38.4	38.4	

RX 800 Series		RXO1 - RXV1						
		T _{1a}						
		i < 11	i < 12	i < 13	11,1 < i < 19,6	12,1 < i < 19,6	13,1 < i < 19,6	i > 19,7
802		—	462	—	—	307	—	219
804		—	462	—	—	307	—	219
806		—	517	—	—	344	—	245
808		937	—	—	601	—	—	429
810		—	1639	—	—	1090	—	777
812		—	1639	—	—	1090	—	777
814		—	2148	—	—	1427	—	1018
816		—	3395	—	—	2256	—	1609
818		—	—	4183	—	—	2870	1982
820		4107	—	—	2780	—	—	1982
822		A richiesta On request Auf anfrage						
824		A richiesta On request Auf anfrage						

RX 800 Series		RXO2 - RXV2						
		T _{1a}						
		i < 47,5	i < 53	47,6 < i < 77	53,1 < i < 80	47,6 < i < 82	i > 77,1	i > 82,1
802		160	—	—	—	107	—	76
804		196	—	—	—	131	—	93
806		462	—	—	—	307	—	219
808		462	—	—	—	307	—	219
810		517	—	—	—	344	—	245
812		904	—	601	—	—	429	—
814		1639	—	1090	—	—	777	—
816		1639	—	1090	—	—	777	—
818		2148	—	1427	—	—	1018	—
820		3395	—	—	—	2256	—	1609
822		—	4183	—	2780	—	—	1982
824		4107	—	2780	—	—	—	1982
826		—	6891	—	4670	—	—	3287
828		A richiesta / On request / Auf anfrage						
830		A richiesta / On request / Auf anfrage						

T_{2r} = Coppia uscita moto retrogrado;
RD = Rendimento dinamico riduttore;
ir = rapporto riduzione

T_{1a} = Coppia limite in ingresso del dispositivo antiretro - [Nm].

T_{2r} = output torque retrograde motion;
RD = gearbox dynamic performance;
ir = reduction ratio

T_{1a} = income limit torque for back-stop device - [Nm].

T_{2r} = Rückläufiges Abtriebsdrehmoment
RD = Dynamischer Getriebewirkungsgrad
ir = Untersetzungsverhältnis

T_{1a} = Grenzantriebsmoment der Rücklauf- sperre - [Nm].

RX 800 Series	RX03 - RXV3						
	T _{1a}						
	i < 240	i < 263	240,1 < i < 369	263 < i < 369	263 < i < 410	i > 369,1	i > 410,1
802	—	53	—	—	36	—	25
804	—	53	—	36	—	25	—
806	—	100	—	—	67	—	47
808	—	160	—	—	107	—	76
810	—	234	—	—	155	—	111
812	—	371	—	—	247	—	176
814	—	424	—	—	282	—	201
816	462	—	307	—	—	219	—
818	—	837	—	—	556	—	397
820	—	1339	—	—	890	—	634
822	A richiesta / On request / Auf anfrage						
824							
826							
828							
830							
832							

T_{2r} = Coppia uscita moto retrogrado;
 RD = Rendimento dinamico riduttore;
 ir = rapporto riduzione

T_{2r} = output torque retrograde motion;
RD = gearbox dynamic performance;
ir = reduction ratio

T_{2r} = Rückläufiges Abtriebsdrehmoment
 RD = Dynamischer Getriebewirkungsgrad
 ir = Untersetzungsverhältnis

T_{1a} = Coppia limite in ingresso del dispositivo antiretro - [Nm].

T_{1a} = income limit torque for back-stop device - [Nm].

T_{1a} = Grenzantriebsmoment der Rücklaufsperr - [Nm].

1.4 Verifiche

1.4 Verification

1.4 Überprüfungen

12) Verifica peso motore elettrico:

12) Verify of the electric motor weight:

12)Überprüfung des

RX 700 Series

Qualora la grandezza del motore elettrico installato sia maggiore della IEC 180 (peso 165 Kg) e qualora la posizione di montaggio del riduttore sia tale da porre il motore nelle posizioni 1-2-3 è necessario contattare il nostro servizio tecnico per verificare se l'installazione è idonea, considerando il peso del motore installato e il fattore di servizio dell'applicazione.

If the input electric motor is bigger than IEC 180 (weight 165 Kg) and the mounting position is 1-2-3, it will be necessary to contact our technical sales department to check the electric motor weight and the service factor of the installation.

Wenn der elektrische Antriebsmotor größer als IEC 180 (ca. 165 kg Gewicht) und in Position 1 bis 3 montiert ist, kontaktieren sie bitte unsere technische Verkaufsabteilung wegen Überprüfung von Gewicht und Servicefaktor.

P_{KG} - peso motore elettrico

P_{KG} - Electric motor weight

P_{KG} - Gewicht E-Motor

13) Coppia frenatura-Motore Autofrenante

13) Braking torque - Brake motor

13) Bremsmoment – Bremsmotor

Nel caso di frenature T_{2max} può essere considerata come quella parte della coppia decelerante (T_{2dec}) che passa attraverso l'asse lento del riduttore:

For braking T_{2max} may be considered as that portion of deceleration torque (T_{2dec}) passing through the gear unit output (low speed) shaft:

Bei Bremsungen kann T_{2max} als der Teil des Beschleunigungsmoments Abbremsmoment (T_{2dec}), der durch die Abtriebsachse des Getriebes läuft, angesehen werden:

$$T_{2max} = T_{2dec} = \left(\left(\frac{T_{1f} \cdot i}{\eta} \right) - T_{2n} \right) \cdot \left(\frac{J}{J + \frac{J_0}{\eta}} \right) + T_{2n} \quad [Nm]$$

dove:
J: momento d'inerzia della macchina e del riduttore ridotto all'asse motore (kgm²)
J₀: momento d'inerzia delle masse rotanti sull'asse motore (kgm²)
T_{1f}: coppia frenante dinamica (Nm)

Where:
J: machine and gear unit inertial load reflected to motor shaft (kgm²)
J₀: inertial load of rotating parts at motor shaft (kgm²)
T_{1f}: dynamic braking torque (Nm)

Hier ist:
J: An der Motorachse reduziertes Trägheitsmoment der Maschine und des Getriebes (kgm²)
J₀: Trägheitsmoment der an der Motorachse drehenden Massen (kgm²)
T_{1f}: dynamisches Bremsmoment (Nm)

Prima della messa in servizio del riduttore è necessario verificare la seguente relazione:

Before using the gearbox, it's necessary to verify the following formula:

Vor Verwendung des Motors ist nach unten stehender Formel sicherzustellen:

$$T_{2max} < 2xT_N$$

Qualora la condizione non sia rispettata è necessario provvedere alla regolazione della coppia di frenatura.

If the condition is not respected, it will be necessary to adjust the braking torque.

Wenn diese Bedingung nicht erreicht wird, ist es notwendig das Bremsmoment entsprechend einzustellen.



1.5 Stato di fornitura

1.5.1 Verniciatura e protezione - RX 700

I riduttori sono verniciati esternamente con smalto a polvere termoidurente blu RAL 5010, salvo disposizioni contrattuali diverse

La protezione è idonea a resistere a normali ambienti industriali anche esterni, e a consentire finiture ulteriori con vernici sintetiche.

Per maggiori informazioni relative allo stato di fornitura vedere la tabella seguente

Caratteristiche della Vernice

Le caratteristiche della vernice utilizzata sono le seguenti: polvere termoidurente a base di resine poliesteri, modificate con resine epossidiche.

A richiesta è possibile fornire:

- 1-Ciclo di verniciatura;
- 2-Le caratteristiche di spessore, durezza, resistenza alla corrosione;
- 3-Scheda tecnica della Polvere utilizzata.

Nel caso si prevedano condizioni ambientali particolarmente aggressive occorre adottare prodotti adeguati apposti con opportuno ciclo di verniciatura. In questi casi si suggerisce di concordare il ciclo in fase di ordine. (TYP0-TYP1-TYP2-TYP3-TYP4).

1.5.2 Protezione alla corrosione e protezione superficiale - RX 800

General information

GSM propone diverse soluzioni protettive opzionali per motori e riduttori che lavorano in speciali condizioni ambientali.

Le misure protettive sono costituite da:

- Protezione corrosiva e protezione superficiale per motori e riduttori;
- Colore Standard RAL 5010

1.5.2.1 - Protezione Corrosiva

La protezione corrosiva è ottenuta con le seguenti specifiche come standard:

- Le targhette sono realizzate in acciaio inox;
- Applicazione di un prodotto anticorrosivo temporaneo per proteggere le superfici di accoppiamento delle flange e gli alberi uscita.

Nel caso di specifiche richieste è possibile applicare tutte le viti di fissaggio in acciaio inox.

1.5.2.2 - Verniciatura e protezione Superficiale

I riduttori preventivamente sabbiati vengono verniciati con vernice ad alto solido, internamente antiolio ed esternamente con fondo epossidico anticorrosivo di colore grigio o rosso ricoperto da finitura poliuretanica bicomponente di colore Blu RAL 5010 (TYP1).

La protezione ottenuta è idonea a resistere in ambienti mediamente corrosivi, industriali interni ed esterni e consente ulteriori finiture a scelta del cliente.

Nel caso si debbano prevedere impieghi in ambienti industriali più aggressivi o corrosivi o estremi o più genericamente di tipo marino, occorre adottare prodotti adeguati apposti con opportuno ciclo di verniciatura. In questi casi si suggerisce di concordare il ciclo in fase di ordine.

La GSM comunque propone già cicli di verniciatura speciali selezionati per ambienti di questo tipo (TYP2 - TYP3 - TYP4).

1.5 Scope of the supply

1.5.1 Painting and protection - RX 700

The gearboxes are painted on surface with powder thermosetting blue RAL 5010 top coating, if there are not different agreements.

The protection is suitable to stand normal industrial environments, also outdoors, and allows additional synthetic paint finishes.

For further details about the supply conditions, please refer to the following table

Paint features

The features of the paint used are the following: thermosetting powder-coating based on polyester resins, modified with epoxy resins.

On request, we can supply:

- 1-Painting cycle specs;
- 2-Specifications for thickness, hardness, resistance to corrosion;
- 3-Technical data sheet of the Powder coating used.

In case of particularly aggressive weather condition it is necessary to paint the gearboxes with a special painting cycle. We suggest you to specify your requests while ordering our products. (TYP0-TYP1-TYP2-TYP3-TYP4).

1.5.2 - Corrosion and surface protection - RX 800

General information

GSM offers different protective solutions for motors and gearboxes which work in special weather condition

The protective measures are:

- Corrosion and surface protection for motors and gearboxes;
- Standard color RAL 5010

1.5.2.1 - Corrosion protection

The corrosion protection is the result of the following standard procedures:

- The name plates are made of inox steel;
- An anticorrosive temporary product is applied on the mechanized surfaces of flanges and output shafts

In case of special requests it is possible to use inox steel screws

1.5.2.2 - Painting and surface protection

Gearboxes, after being sand blasted, are painted with a specific paint, which has a double function. On the internal side it works as an anti-oil, while on the external side it works as a grey or red anticorrosive epoxy primer covered by a blue RAL 5010 (TYP 1) bi-component polyurethane finishing paint.

The above mentioned protection is suitable for internal and external industrial environments with corrosive effects on the average. It also gives to the customer the possibility to chose other finishing effects.

In case of use in aggressive or corrosive industrial or sea environments, it is necessary to use special products with the required painting cycle. We suggest you to specify these particular terms with our company.

GSM offers already special painting cycles, which have been created for these kind of environments (TYP2 - TYP3 - TYP4).

1.5 Lieferzustand

1.15.1 Lackierung und schutz - RX 700

Die Getriebe sind außen mit wärmehärtenden blauen, RAL 5010, Lack lackiert, außer anderweitig lautende vertragliche Vereinbarungen.

Dieser Schutz ist für einen Einsatz in normalen industriellen, auch im Freien liegenden Umfeldern geeignet und erlaubt Überlackierungen mit Synthetiklack.

Weitere Informationen zum Lieferzustand können der folgenden Tabelle entnommen werden.

Eigenschaften der Lackierung

Der verwendete Lack weist folgende Eigenschaften auf: wärmehärtender Pulverlack auf Polyesterharzbasis mit Epoxidharzen modifiziert.

Auf Anfrage erhältlich:

- 1-Lackierungszyklus;
- 2-Stärke, Härte, Korrosionsfestigkeit;

3-Technisches Datenblatt des verwendeten Pulverlacks.

Bei besonders aggressiven Umweltbedingungen müssen hierfür geeignete Produkte mit den entsprechenden Lackierzyklen verwendet werden. In diesen Fällen wird vorgeschlagen, dass Sie den Zyklus in der Auftragsphase vereinbaren.(TYP0-TYP1-TYP2-TYP3-TYP4).

1.5.2 - Korrosionsschutz und Oberflächenschutz - RX 800

Allgemeine Information

GSM bietet optional verschiedene Schutzmöglichkeiten für Motoren und Getriebe an, die in besonderen Umweltbedingungen arbeiten

Die Schutzmaßnahmen bestehen aus:

- Korrosionsschutz und Oberflächenschutz für Motoren und Getriebe;
- Standardfarbe RAL 5010

1.5.2.1 - Korrosionsschutz

Der Korrosionsschutz ist bei den folgenden Spezifikationen standardmäßig:

- Die Typenschilder sind aus Edelstahl;
- Anwendung eines temporären Antikorrosionsproduktes als Oberflächenschutz für die Flansch und Abtriebswellenverbindungen

Im Falle spezifischer Anfragen können alle Befestigungsschrauben aus Edelstahl verwendet werden.

1.5.2.2 - Lackierung und Oberflächenschutz

Die vorbeugend sandgestrahlten Getriebe werden mit Farbe mit hohem Feststoffgehalt lackiert, innen gegen das Öl und außen gegen Korrosion mit Epoxid in grauer oder roter Farbe. Und werden abschließend mit Bikomponentenpolyurethan in der Farbe blau RAL 5010 (TYP 1) überzogen..

Der erreichte Schutz ist geeignet für Bereiche mit durchschnittlicher Korrosion, für den industriellen Innen- und Außeneinsatz geeignet und erlaubt eine zusätzliche Endbearbeitung gemäß Kundenwunsch.

Sollte der Einsatz in industriellen Bereichen erfolgen, die aggressiver oder korrosiver oder extremer oder allgemein den marinen Bereich betreffen, müssen hierfür geeignete Produkte mit den entsprechenden Lackierzyklen verwendet werden. In diesen Fällen wird vorgeschlagen zuzustimmen.

Die GSM schlägt hier jedoch bereits speziell ausgewählte Lackierzyklen für Bereiche dieser Art vor (TYP2 - TYP3 - TYP4).

1.5 Stato di fornitura

1.5 Scope of the supply

1.5 Lieferzustand

RX 800 Series

Protezione superficiale Surface protection	Numero di strati Permutation of layers	Spessore Coat thick nes	Adatto per Suitable for
TYP 1 "STANDARD"	1x Primer 1x Two-component top coat	Circa/Approx. 120 micron A Secco/Dry	1 - Impatto ambientale BASSO - (condizioni ambientali normali) Low enviroment impact (Normal ambient condition) 2 - Umidità relativa inferiore al 90% Relative humidity below 90 % 3 - Temperatura superficiale massima. 120 °C Surface temperature up to max. 120 °C 4 - Categoria di corrosività " C3-M " (DIN EN ISO 12,944-2) Corrosivity category " C3-M " (DIN EN ISO 12,944-2)
TYP 2 Standard Rinforzato Standard Reinforced	1x Primer 1x Two-pack Intermediate 1x Two-pack top coat	Circa/Approx. 160 micron A Secco/Dry	1 - Impatto ambientale MEDIO Medium environmental impact 2 - Umidità relativa massima 95 % Relative humidity max. 95 % 3-Temperatura superficiale massima 120 °C Surface temperature up to max. 120 °C 4 -Categoria di corrosività " C4-M " (DIN EN ISO 12,944-2) Corrosivity category " C4-M " (DIN EN ISO 12,944-2)
TYP 3 Industriale Industrial	1x Primer 2x Two-pack Intermediate 1x Two-pack top coat	Circa/Approx. 240 micron A Secco/Dry	1 - Impatto ambientale ALTO - Applicazione industriale High environmental impact - Industrial Application 2 - Umidità relativa massima 100 % Relative humidity max. 100 % 3-Temperatura superficiale massima 120 °C Surface temperature up to max. 120 °C 4 - Categoria di corrosività " C5I-M " (DIN EN ISO 12,944-2) Corrosivity category " C5I-M " (DIN EN ISO 12,944-2)
TYP 4 Marino Marine	1x Zinc Primer 2x Two-pack Intermediate 2x Two-pack top coat	Circa/Approx. 320 micron A Secco/Dry	1 - Alto impatto ambientale - Applicazione ambiente marino High environmental impact - Marine Application 2 - Umidità relativa massima 100 % Relative humidity max. 100 % 3-Temperatura superficiale massima 120 °C Surface temperature up to max. 120 °C 4 - Categoria di corrosività " C5M-M " (DIN EN ISO 12,944-2) Corrosivitycategory " C5M-M " (DIN EN ISO 12,944-2)

A richiesta é possibile fornire ciclo di verniciatura ,schede tecniche dei prodotti utilizzati e report di prova
If requested, we can supply you with painting procedures, data sheets of the products which have been used and testing reports
Auf Anfrage ist es möglich den Lackierzyklus, technische Leistungsblätter der benutzten Produkte und Testberichte zur Verfügung zu stellen

OPT2 - Opzioni - Verniciatura
Options - Painting and surface protection
Optionen - Lackierung und Oberflächenschutz

Serie Series Baureihe	Verniciatura Interna Inner painting Innenlackierung	Verniciatura Esterna Outer painting Außenlackierung	Piani lavorati Machined surfaces Bearbeitete Flächen	Alberi Shafts Wellen
		Tipo e Caratteristiche vernice Paint type and features Lacktyp und -eigenschaften	Verniciabile Can be painted Kann lackiert werden	
TypSTM				
RX 700 Series	Uguale a verniciatura esterna Same as outer painting Wie Außenlackierung	Verniciatura a Polvere RAL 5010 Powder coating RAL 5010 Pulverlackierung RAL 501	SI Dopo Grassatura e Carteggiatura e applicazione di un PRIMER Yes After Degreasing and sanding and/or application of a PRIMER Ja Nach Fettentfernung und Abschiff und/oder Auftrag eines PRIMER	Quando il materiale è la ghisa sono protetti con prodotto antiruggine. When material is cast iron, they are protected with rustproof oil. Falls aus Gusseisen mit Rostschutzöl geschützt
				Protetti con prodotto antiruggine. Protected with rustproof oil. Mit Rostschutzöl geschützt
TYP 1				
RX 800 Series	fondo epossidico anticorrosivo di colore grigio o rosso Grey or red anticorrosive epoxy primer Epoxidkorrosionsschutz in grauer oder roter Farbe	ricoperto da finitura poliuretanica bicomponente di colore Blu RAL 5010 (TYP1) Covered by a blue RAL 5010 (TYP 1) bi-component polyurethane finishing paint überzogen mit Bikomponentenpolyrethan in der Farbe blau RAL 5010 (TYP 1)	SI	Protetti con prodotto antiruggine. Protected by oxide protectant Mit Rostschutzpaste geschützt.
				Protetti con prodotto antiruggine Protected by oxide protectant Mit Rostschutzpaste geschützt.

ATTENZIONE
In caso di verniciatura o asportazione del prodotto antiruggine si chiede di porre attenzione alla preventiva protezione:
- Delle superfici lavorate, al fine di evitare che una eventuale verniciatura delle stesse pregiudichi il successivo accoppiamento.
-Delle tenute e più in generale di ogni parte plastica e di gomma, al fine di non variarne le caratteristiche chimico fisiche pregiudicandone così l'efficienza.
-Alla targa di identificazione per evitare la perdita di tracciabilità.
-Al tappo sfiato ed al tappo di livello olio, al fine di evitarne l'occlusione.

ATTENTION
If the product must be painted or cleaning off any antirust paint, protect the machined surfaces and oil seals/gaskets in order to prevent any damage. It is also necessary to protect the identification plate, the oil level plug (if fitted) and the hole in the breather plug (if fitted) against obstruction.

ACHTUNG
Sollten die Produkte lackiert werden oder Abbau des Rostschutzmittels, muss darauf geachtet werden, dass die bearbeiteten und Dichtflächen dabei geschützt werden, so dass verhindert werden kann, dass die Lackierung die chemisch-physischen Eigenschaften verändert und die Wirkung der Öabdichtungen einschränkt. In der gleichen Weise und aus gleichem Grund müssen das Typenschild und die Öleinfüllschraube sowie die Bohrung der Entlüftungsschraube (wo vorhanden) geschützt werden.

1.5 Stato di fornitura

1.5 Scope of the supply

1.5 Lieferzustand

1.5.3 MATERIALI COSTRUTTIVI

1.5.3 MATERIAL

1.5.3 KOSTRUKTIONSMATERIAL

1.5.3.1 Casse - Flange - Coperchi

1.5.3.1 Housings - Flanges - Covers

1.5.3.1 Gehäuse - Flanschen – Deckel

Serie Series Baureihe	Per ulteriori informazioni vedere 1.6.5 For more details, please read 1.6.5 Sie können Weitere Informationen siehe 1.6.5
RX 700 RX 800	

1.5.3.2 Materiale degli anelli di tenuta

1.5.3.2 Materials of Seals

1.15.2.2 Dichtungstoffe

Serie Series Baureihe	OPT Opzioni - Materiale degli anelli di tenuta Options - Materials of Seals Optionen - Dichtungstoffe	
	— (Tenute STANDARD Oil Seals Standard Ölabdichtungen Standard) Opzioni - Disponibile Options Available Optionen - verfügbar
RX 700 RX 800	Per ulteriori informazioni vedere SEZIONE U For more details, please read SECTION U Sie können Weitere Informationen siehe ABSCHNITT U	

1.5.4 Lubrificazione

1.5.4 Lubrication

1.5.4 Schmierung

RX 700	OPT1 - Opzioni - Stato fornitura olio Options - Scope of the supply - Options - OIL Optionen - Lieferzustand - Optionen - Öl	
		Sigla ordine Designation order Bezeichnung Bestellung
	704	INOIL
	708	OUTOIL
	712	
	716	
720		

RX 800	OPT1 - Opzioni - Stato fornitura olio Options - Scope of the supply - Options - OIL Optionen - Lieferzustand - Optionen - Öl	
		Sigla ordine Designation order Bezeichnung Bestellung
	all sizes	OUTOIL

1.5 Stato di fornitura

1.5 Scope of the supply

1.5 Lieferzustand

1.5.4 Lubrificazione

1.5.4 Lubrication

1.5.4 Schmierung

ATTENZIONE:

Lo stato di fornitura è messo in evidenza con una targhetta adesiva posta sul riduttore.

Verificare la corrispondenza tra stato di

CAUTION:

Gearbox state of supply is indicated on a nameplate applied on gearbox.

Ensure that nameplate data and state of supply correspond.

ACHTUNG:

Der entsprechende Lieferzustand wird auf einem Aufkleber am Getriebe angegeben. Überprüfen Sie die Übereinstimmung zwischen effektivem Lieferzustand und Auf-

OPT1 - Opzioni - Stato fornitura olio- Options - Scope of the supply - Options - OIL Optionen - Lieferzustand - Optionen - Öl				
Stato fornitura Scope of the supply Lieferzustand	Riduttore - Lubrificazione Gearbox - Lubrication Getriebe - Schmierung	Tipo Type Typ	NOTE Note Hinweis	Targhetta Namplate Aufkleber
OUTOIL Riduttore Privo di Lubrificante <i>Gearbox with no lubricant</i> Getriebe ohne Schmiermittel	Si consiglia l'uso di oli a base sintetica. Vedere a tale proposito le indicazioni riportate paragrafo 1.8. The use of synthetic oil is recommended. see details in paragraph 1.8. Der Einsatz von synthetischem Öl wird empfohlen. Siehe diesbezüglich die Hinweise im Abschnitt 1.8.		Se richiedi completi di lubrificante, verranno forniti con olio standard - "INOIL_STD" If customer requests supply of gearbox with lubricant, we shall supply - "INOIL_STD" Falls diese Getriebe mit Schmiermittelfüllung angefordert werden - "INOIL_STD"	
INOIL_STD Riduttore Completo di Lubrificante Standard STM <i>Gearbox with lubricant STM standard</i> Getriebe mit Standard Schmiermittel STM	RX700 OMALA S4 WE 320	OilGear_TYPE CLP PG Synthetic PG	—	
	RX 800 AGIP BLASIA 220	OilGear_TYPE CLP Mineral		
INOIL_Food Riduttore Completo di Lubrificante "ALIMENTARE" <i>Gearbox with lubricant "FOOD-TYPE"</i> Getriebe mit Schmiermittel "LEBENSMITTEL"	RX 700 - RX 800 CASSIDA GL 320	OilGear_TYPE CLP HCE Synthetic HCE NSF H1	—	
ASOIL Riduttore Completo di Lubrificante Speciale - a richiesta <i>Gearbox with Special lubricant - On request</i> Getriebe mit Sondern-Schmiermittel - Auf Anfrage	A richiesta On request Auf Anfrage	OilGear_TYPE CLP PG Synthetic PG	—	
		OilGear_TYPE CLP HC Synthetic PAO		
		OilGear_TYPE CLP Mineral		
		OilGear_TYPE CLP HCE Synthetic HCE NSF H1		
		Grease		

Nota campo- ASOIL

Nella targhetta sono riportate le seguenti informazioni:

- Code_Plate;
- Sigla lubrificante;
- ISO VG;
- Type DIN;
- NSF;
- Altre prescrizioni.

Note range-ASOIL

The type plate contains the following information:

- Code_Plate
- Lubricant type
- ISO VG
- Type DIN
- NSF
- other details

Hinweis Bereich-ASOIL

Auf dem Typenschild finden Sie folgende Informationen:

- Code_Plate
- Schmiermitteltyp
- ISO VG
- Type DIN
- NSF
- andere Hinweise

1.5 Stato di fornitura

1.5.4 Lubrificazione

Riduttori forniti con il cuscinetto schermato

Se ne consiglia il ringrassaggio indipendentemente dalle ore di esercizio effettuate, dopo almeno 2-3 anni.

Pertanto è stato predisposto un ingrassatore per provvedere all'opportuno ringrassaggio.

Le Caratteristiche tecniche generali del grasso utilizzato sono:

- Inspessente: base di Litio Complesso;
- NGLI: 2;
- Olio: HCE - con additivazione EP di viscosità minima ISO VG 220;
- Additivi: l'olio presente nel grasso deve avere caratteristiche di additivazione EP;

SPECIFICHE E APPROVAZIONI
DIN51502: **KP-HCE-2 P-40**

1.5.5 Antiretro

Qualora sia presente un dispositivo antiretro una freccia ne evidenzia il senso di rotazione consentito.

1.6 Normative applicate

1.6.1 Specifiche prodotti non "ATEX"

I riduttori della GSM SpA sono organi meccanici destinati all'uso industriale e all'incorporazione in apparecchiature meccaniche più complesse. Dunque non vanno considerati macchine indipendenti per una predeterminata applicazione ai sensi 2006/42/CE, né tantomeno dispositivi di sicurezza.

1.5 Scope of the supply

1.5.4 Lubrication

Worm gearboxes with a shielded bearing

It is recommended to grease it at least every 2-3 years regardless of the operating hours.

To this end it is provided with a greaser.

Following are the general technical features of the lubrication grease:

- Thickener: Complex Lithium-based;
- NGLI: 2;
- Oil: HCE with EP additives with minimum viscosity as per ISO VG 220;
- Additives: the oil in the grease must feature EP additive;

SPECIFICATIONS AND APPROVALS
DIN51502: **KP-HCE-2 P-40**

1.5.5 Back-stop device

In the event a back-stop device is provided, an arrow indicates its permitted direction of rotation.

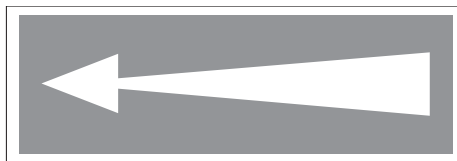

1.6 Standards applied

1.6.1 Specifications of non - "ATEX"

products

GSM SpA gearboxes are mechanical devices for industrial use and incorporation in more complex machines. Consequently, they should not be considered neither self-standing machines for a pre-determined application according to 2006/42/EEC nor safety devices.

1.5 Lieferzustand

1.5.4 Schmierung

Getrieben mit abgeschirmtem Lager geliefert werden

Wir empfehlen, unabhängig von den erfolgten Betriebsstunden, mindestens alle 2-3 Jahre ein entsprechendes Nachschmieren.

Daher wurde ein angemessener Schmiernippel für das Nachschmieren vorgesehen.

Allgemeine technische Eigenschaften des verwendeten Fetts:

- Verdickungsmittel: auf Lithiumkomplex;
- NGLI: 2;
- Öl: HCE mit Zusatz von EP mit Mindestviskosität gemäß ISO VG 220;
- Additive: das im Fett enthaltene Öl muss die Eigenschaften der EP Additivierung aufweisen;

SPEZIFIKATIONEN
DIN51502: **KP-HCE-2 P-40**

1.5.5 Rücklaufsperr

Sollte eine Rücklaufsperr vorhanden sein, wird die zulässige Drehrichtung durch einen Pfeil angegeben.

1.6 Angewendete Normen

1.6.1 Spezifikationen für produkte, die

nicht der "ATEX"-norm entsprechen
Bei den Getrieben der GSM SpA handelt es sich um Mechanikorgane, die für den industriellen Einsatz und einen Einbau in komplexere Einrichtungen bestimmt sind. Sie werden deshalb weder unter dem Aspekt unabhängiger, für eine bestimmte Anwendung vorgesehener Maschinen im Sinne der 2006/42/EEG, noch als Sicherheitsvorrichtungen berücksichtigt.

1.6 Normative applicate

1.6.2 Specifiche prodotti "ATEX"

Campo applicabilità

La direttiva ATEX (2014/34/UE) si applica a prodotti elettrici e non elettrici destinati a essere introdotti e svolgere la loro funzione in atmosfera potenzialmente esplosiva. Le atmosfere potenzialmente esplosive vengono suddivise in gruppi e zone a seconda della probabilità di formazione. I prodotti GSM sono Conformi alla seguente classificazione:

- 1- Gruppo: II
2- Categoria: **Gas 2G polveri 2D**
3- Zona: Gas 1 ; 2 – Polveri 21;22

1.6 Standards applied

1.6.2 Specifications of "ATEX" products

Application field

ATEX set of provisions (2014/34/UE) is referred to electric and non-electric products which are used and run in a potentially explosive environment. The potentially explosive environments are divided into different groups and zones according to the probability of their formation. GSM products are in conformity with following classification:

- 1- Group : II
2- Type : **Gas 2G dust 2D**
3-Zone : Gas 1;2 – Dust 21;22

1.6 Angewendete Normen

1.6.2 Spezifikationen für "ATEX"-produkte

Anwendungsbereich

Die ATEX-Richtlinie (2014/34/UE) wird bei elektrischen und nicht elektrischen Produkten angewendet, die dazu bestimmt sind, in potentiell explosionsfähigen Atmosphären eingesetzt und betrieben zu werden. Die potentiell explosionsfähigen Atmosphären werden in Abhängigkeit der Wahrscheinlichkeit in Gruppen und Zonen unterteilt. Die GSM-Produkte entsprechen der folgenden Klassifizierung:

- 1- Gruppe: II
2- Kategorie: **Gas 2G Staub 2D**
3- Zone: Gas 1;2 - Staub 21;22

Massime temperature di superficiali / Max surface temperature allowed / Maximale Oberflächentemperaturen					
Classe di temperatura / Temperature class / Temperaturklasse	T1	T2	T3	T4	T5(1)
Massima temp.di superficie / Max surface temperature / Max. Oberflächentemperaturen (°C)	450	300	200	135	100(1)
Classi di temperatura ATEX dei prodotti GSM / ATEX temperature class of GSM products / ATEX Temperaturklassen der GSM-Produkte					

I prodotti GSM sono marcati classe di temperatura **T4** per IIG (atmosfera gassosa) e **135° C** per IID (atmosfera polverosa).

Nota 4:

Nel caso di Classe di temperatura T5 occorre verificare la potenza limite termico declassata;

In tutti gli altri casi vale la potenza riportata a catalogo prevista per i singoli rapporti con fattore di servizio complessivo dell'applicazione pari a 1 e le considerazioni sul limite termico.

I prodotti del gruppo IID (atmosfera polverosa) vengono definiti dalla massima temperatura di superficie effettiva.

La massima temperatura di superficie è determinata in normali condizioni di installazione e ambientali (-20°C e +40°C) e senza depositi di polvere sugli apparecchi. Qualunque scostamento da queste condizioni di riferimento può influenzare notevolmente lo smaltimento del calore e quindi la temperatura.

GSM products are branded temperature class **T4** for IIG (gas environment) and **135°C** for IID (dust environment).

Note 4:

In case of T5 Class of temperature the extreme down-graded thermic power should be checked.

In all the other instances, the power indicated on the catalogue for the single ratios with overall application service factor equal to 1 and the considerations on temperature limits apply.

The products of the family IID (dust environment) are defined by the max effective surface temperature.

Max surface temperature is determined in standard installation and environmental conditions (-20°C and +40°C) and in absence of dust on product surface. Any other condition will modify the heat dissipation and consequently the temperature.

Die GSM-Produkte sind mit der Temperaturklasse **T4** für IIG (Atmosphäre mit gasförmiger Belastung) und **135° C** für IID (Atmosphäre mit staubförmiger Belastung) gekennzeichnet.

Hinweis 4:

Bei der Temperaturklasse T5 muss die zurückgestufte thermische Grenzleistung überprüft werden. In den anderen Fällen gilt die im Katalog für die einzelnen Übersetzungsverhältnisse angegebene Leistung mit Betriebsfaktor einschließlich Applikation entsprechend 1 und die Berücksichtigungen im Hinblick auf die thermische Grenzleistung.

Die der Gruppe IID (Atmosphäre mit staubförmiger Belastung) angehörigen Produkte werden ihrer effektiven maximalen Oberflächentemperatur gemäß definiert.

Die maximale Oberflächentemperatur wird in normalen Einbau- und Umgebungsbedingungen (-20°C und +40°C) und ohne auf den Vorrichtungen vorhandenen Staubablagerungen bestimmt.

Jegliche Abweichung von diesen Bezugsbedingungen kann sich erheblich auf die Wärmeableitung bzw. auf die Betriebstemperatur auswirken.

1.6.3. COME SI APPLICA

Al momento di una richiesta di offerta per prodotto conforme a normativa ATEX 2014/34/UE occorre compilare la **scheda acquisizione dati** (www.stmspa.com).

Effettuare le verifiche come prima descritto.

I riduttori certificati verranno consegnati con:
-una seconda targhetta contenente i dati ATEX;
-ove previsto un tappo sfiato, tappo sfiato con molla interna;

-se rispondente alla classe di temperatura T4 e T5 verrà allegato un indicatore di temperatura (132 °C nel caso di T4 e 99°C rispettivamente per la T5)

-Indicatore di temperatura : termometro a singolo rilevamento, una volta raggiunta la temperatura indicata si annerisce segnalando il raggiungimento di tale limite.

1.6.3. HOW IS IT APPLIED

In case of request of offer relating to any product in conformity with the provisions ATEX/2014/34/UE, the **specifications paper** should be filled in (www.stmspa.com).

Perform the inspections as described above. Certified reducers will be delivered with:

- a second nameplate containing ATEX data;
- a breather valve with internal spring, where a breather is needed;
- if in accordance with classes of temperature T4 and T5, a temperature gauge will be included (132 °C in case of T4 and 99 °C in case of T5).
- Temperature gauge: single-reading thermometer, it blackens once temperature is reached, pointing out the achievement of that limit.

1.6.2. ANWENDUNGSWEISE

Bei einer Angebotsanfrage für der Richtlinie ATEX 2014/34/UE entsprechende Produkte muss das Datenerfassungsformular (www.stmspa.com) ausgefüllt werden.

Dazu die zuvor beschriebenen Kontrollen vornehmen. Die zertifizierten Getriebe werden wie folgt ausgestattet geliefert:

- mit einem zweiten Typenschild mit ATEX- Daten;
- wo vorgesehen, mit einem Entlüftungs- verschluss, Entlüftungsverschluss mit interner Feder;
- falls der Temperaturklasse T4 und T5 entsprechend, wird eine Temperaturanzeige vorgesehen (132 °C bei T4 und 99°C bei T5)
- Temperaturanzeige: einzelnes Erfassungsthermometer - bei Erreichen der angegebenen Temperatur wechselt die Farbe zur Anzeige der erreichten Temperatur in Schwarz.

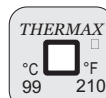
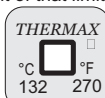

1.6 Normative applicate**1.6.4 Direttive CE- marcatura CE- ISO9001****Direttiva Bassa Tensione 2006/95/CE**

I motoriduttori, motorivii angolari, motorivariatori e i motori elettrici GSM sono conformi alle prescrizioni della direttiva Bassa Tensione .

2004/108/CE Compatibilità elettromagnetica

I motoriduttori, motoriviiangolari, motorivariatori e i motori elettrici GSM sono conformi alle specifiche della direttiva di Compatibilità Elettromagnetica.

Direttiva Macchine 2006/42/CE

I motoriduttori, motoriviiangolari, motorivariatori e i motori elettrici GSM non sono macchine ma organi da installare o assemblare nelle macchine.

Marchio CE, dichiarazione del fabbricante e dichiarazione di conformità.

I motoriduttori, motorivariatori e i motori elettrici hanno il marchio CE.

Questo marchio indica la loro conformità alla direttiva Bassa Tensione e alla direttiva Compatibilità Elettromagnetica.

Su richiesta, GSM può fornire la dichiarazione di conformità dei prodotti e la dichiarazione del fabbricante secondo la direttiva macchine.

ISO 9001

I prodotti GSM sono realizzati all'interno di un sistema di qualità conforme allo standard ISO 9001. A tal fine su richiesta è possibile rilasciare copia del certificato.

1.6.5 Normative riferimento Progettazione e Fabbricazione**Ingranaggi**

Gli ingranaggi cilindrici a dentatura elicoidale, sono rettificati sul profilo ad evolvente dopo cementazione, tempra e rinvenimento finale.

Gli ingranaggi conici a dentatura Gleason sono rodati, (o rettificati a seconda della grandezza del riduttore), dopo cementazione tempra e rinvenimento finale.

Cuscinetti

Tutti i cuscinetti sono del tipo a rulli conici o a rulli orientabili, di elevata qualità e dimensionati per garantire una lunga durata se lubrificati con il tipo di lubrificante previsto a catalogo.

Carcassa

La carcassa è ottenuta per fusione in GJL 250 UNI EN 1561 o in ghisa a grafite sferoidale UNI EN 1563 2004 fino alla grandezza 824-826.

Le grandezze in acciaio sono in S275J2 EN UNI 10025 composto elettrosaldato e disteso. I particolari accorgimenti adottati nel disegno della struttura permettono di ottenere un' elevata rigidità.

1.6 Standards applied**1.6.4 EC Directives-CE mark-ISO 9001****Directive 2006/95 EEC Low VoltageGSM**

geared motors, right angle drives with motor, motorvariators and electric motors meet the specification of the low voltage directive.

2004/108/EEC Electromagnetic Compatibility

GSM geared motors, right angle drives with motor, motorvariators and electric motors correspond to the specifications of the EMC directive.

Machinery Directive 2006/42/EC

GSM geared motors, right angle drives with motor, motorvariators and electric motors are not standalone machines, they are exclusively for installation into a machine or for assembly on a machine.

CE Mark, Conformity Declarations and Manufacturer's Declaration.

GSM geared motors, right angle drives with motor, motorvariators and electric motors carry the CE Mark.

It indicates conformity to the low voltage directive and to electromagnetic compatibility directive.

On request GSM supplies both the conformity declarations and the manufacturer's declaration according to the machine directive.

ISO 9001

GSM products have been designed and manufactured according to ISO 9001 quality system standard.

On request a copy of the certification can be issued.

1.6.5 Standards applied**Gearing**

Helical gear sets are first case hardened, hardened and tempered and finally their involute profile is ground.

Gleason bevel gear sets are first case hardened, hardened and tempered and finally broken in (or ground, depending on gear unit size).

Bearings

All bearings are high quality taper or self-aligning roller bearings suitably sized to ensure long service life provided the approved lubricants indicated in this catalogue are used.

Casings

Casings up to size 824-826 are cast from GJL 250 UNI EN 1561 cast iron or from Spheroidal cast iron.

Sizes use casings fabricated from electrically welded stress relieved S275J2 steel EN UNI 10025.

Casing design incorporates special arrangements to provide superior rigidity.

1.6 Angewendete Normen**1.6.4 EG-Richtlinien - CE-Zeichen - ISO9001****Niederspannungsrichtlinie. 2006/95/EG**

Die Getriebemotoren, Winkelgetriebe, Verstellgetriebe und Elektromotoren der GSM entsprechen den Vorschriften der Niederspannungsrichtlinie.

2004/108/EG**Verträglichkeit**

Die Getriebemotoren, Winkelgetriebe, Verstellgetriebe und Elektromotoren der GSM entsprechen den Vorschriften der Richtlinie zur Elektromagnetischen Verträglichkeit.

Maschinenrichtlinie 2006/42/EG

Die Getriebemotoren, Winkelgetriebe, Verstellgetriebe und Elektromotoren der GSM sind keine Maschinen sondern Organe, die in Maschinen eingebaut oder an diesen montiert werden.

CE-Zeichen, Hersteller- und Konformitätserklärung

Die Getriebemotoren, Verstellgetriebe und Elektromotoren tragen das CE-Zeichen.

Dieses Zeichen weist auf ihre Konformität mit der Niederspannungsrichtlinie und der Richtlinie zur Elektromagnetischen Verträglichkeit hin.

Auf Anfrage kann die GSM die Konformitätserklärung und die Herstellererklärung gemäß Maschinenrichtlinie zu den Produkten liefern.

ISO 9001

Die GSM-Produkte werden in einem Qualitätssystem gemäß dem Standard ISO 9001 realisiert. Auf Anfrage kann daher eine Kopie der Zertifizierung geliefert werden.

1.6.5 Bezugsnormen Entwicklung und Produktion**Zahnräder**

Das Evolventenprofil der Stirnrädergetriebe mit Schrägverzahnung wird nach dem Einsatzhärten, dem Abschrecken und dem Anlassen entsprechend geschliffen.

Die Kegelnzahnäder mit Gleason-Verzahnung sind bereits eingelaufen (oder in Abhängigkeit der Getriebegröße geschliffen), dies erfolgt nach dem Einsatzhärten, Abschrecken und Anlassen.

Lager

Bei allen Lagern handelt es sich um hochqualitative Kegelrollenlager mit orientierungsfähigen Rollen und in Maßen, die so ausgelegt sind, dass sie bei Einsatz der gemäß Katalogangaben vorgesehenen Schmiermittel eine lange Lebensdauer garantieren.

Gehäuse

Die Gehäuse der Getriebe bis Baugröße 824-826 werden im Gussverfahren aus GJL 250 UNI EN 1561 oder Sphäroguss UNI EN 1563 2004 gewonnen.

Die Baugrößen von Stahl werden aus elektroverschweißtem und entspanntem S275J2 EN UNI 10025 realisiert.

Die besonderen beim Entwurf der Struktur berücksichtigten Vorkehrungen verleihen ihr eine besondere Steifheit.

1.6 Normative applicate**Alberi**

RX 700 - Gli alberi lenti sono verificati a flesso-torsione con elevato coefficiente di sicurezza.

Linguette secondo UNI 6604-69, DIN 6885 BI.

RX 800 - Gli alberi lenti sono verificati a flesso-torsione con elevato coefficiente di sicurezza. Le estremità d'albero cilindriche sono secondo UNI 6397-68, DIN 748, NF E 22.051, BS 4506-70, ISO/R 775-69, escluso corrispondenza R-S, con foro filettato in testa secondo DIN 1414. Linguette secondo UNI 6604-69, DIN 6885 BI, 1-68, NF E 27.656 22.175, BS 4235.1-72, ISO/R 773-69 escluso corrispondenza I.

Tutti i prodotti della GSM sono progettati nel rispetto delle seguenti normative:

Calcolo degli ingranaggi e cuscinetti

ISO 6336 - ISO10400 - DIN3991

La capacità di carico è stata calcolata a pressione superficiale e a rottura secondo la normativa ISO 6336 - ISO10400 - DIN3991 (a richiesta sono possibili verifiche secondo le norme AGMA 2001-C95 e AGMA 2003).

BS 721

Calcolo della capacità di carico delle viti e delle corone elicoidali.

ISO 281

Calcolo della durata a fatica dei cuscinetti volventi.

Alberi

DIN 743

Calcolo della durata a fatica degli alberi

Materiali

EN 10084

Acciaio da cementazione per ingranaggi e viti senza fine.

EN 10083

Acciaio da bonifica per alberi.

EN UNI 10025

Acciaio - Casse

UNI EN 1982 - UNI 5274

Bronzo per corone elicoidali.

UNI EN 1706

Alluminio e leghe di Alluminio

UNI EN 1561

Fusioni in ghisa grigia.

UNI EN 1563 2004

Getti di ghisa a grafite sferoidale

UNI 3097

Acciaio per cuscinetti per piste rotolamento.

1.6 Standards applied**Shafts**

RX 700 - Output shafts are calculations incorporate a high safety factor and are validated by bending and torsional stress analyses.

Keys are in accordance with UNI 6604-69, DIN 6885 BI.

RX 800 - Output shafts are calculations incorporate a high safety factor and are validated by bending and torsional stress analyses. Cylindrical shaft ends are in accordance with UNI 6397-68, DIN 748, NF E 22.051, BS 4506-70, ISO/R 775-69, excluding section R-S, with centre tapped hole at shaft end to DIN 1414. Keys are in accordance with UNI 6604-69, DIN 6885 BI, 1-68, NF E 27.656 22.175, BS 4235.1-72, ISO/R 773-69 excluding section I.

All GSM products are designed following these standards:

Calculation of gearboxes and bearings

ISO 6336 - ISO10400 - DIN3991

The load capacity of gear sets is calculated at contact and root bending stress in accordance with standard ISO 6336 - ISO10400 - DIN3991

(gears can be rated to AGMA 2001-C95 and AGMA 2003 on request).

BS 721:

Calculation of load capacity for worm gearing.

ISO 281:

Rolling bearings — Dynamic load ratings and rating life

Shafts

DIN743

Shafts — Dynamic load ratings and rating life

Materials

EN 10084

Case hardening steels for gears and worms

EN 10083

Quenched and Tempered Steels for shafts

EN UNI 10025

Steel - Casing

UNI EN 1982 - UNI 5274

Copper for helical worm-gears

UNI EN 1706

Aluminium alloy

UNI EN 1561

Grey iron casting

UNI EN 1563 2004

Spheroidal cast iron

UNI 3097

Ball and roller bearing steel

1.6 Angewendete Normen**Wellen**

RX 700 - Die Abtriebswellen werden unter Berücksichtigung eines hohen Sicherheitskoeffizienten auf Biegung-Windung getestet.

Die Federkeile entsprechen UNI 6604-69, DIN 6885 BI.

RX 800 - Die Abtriebswellen werden unter Berücksichtigung eines hohen Sicherheitskoeffizienten auf Biegung-Windung getestet.

Die Enden der zylindrischen Wellen entsprechen den Normen UNI 6397-68, DIN 748, NF E 22.051, BS 4506-70, ISO/R 775-69, ausgenommen Zuordnung R-S, mit Gewindebohrung in der Wellenspitze DIN 1414. Die Federkeile entsprechen UNI 6604-69, DIN 6885 BI, 1-68, NF E 27.656 22.175, BS 4235.1-72, ISO/R 773-69, ausgenommen Zuordnung I.

Alle Produkte der GSM werden unter Einhaltung folgender Normen entwickelt:

Berechnung der Zahnräder und Lager

ISO 6336 - ISO10400 - DIN3991

Die Belastbarkeit wurde auf Oberflächendruck und Bruch der Richtlinie ISO 6336 - ISO10400 - DIN3991 - gemäß berechnet (auf Anfrage können Überprüfungen den Normen AGMA 2001-C95 und AGMA 2003 gemäß vorgenommen werden).

BS 721

Berechnung der Belastungsfähigkeit der Schnecken und Schrägzahnräder.

ISO 281

Berechnung der Belastungsdauer der Wälzlager.

Wellen

DIN743

Berechnung der Belastungsdauer der Wellen.

Material

EN 10084

Einsatzstahl für Zahnräder und Schnecken.

EN 10083

Vergütungsstahl für Wellen.

EN UNI 10025

Stahl - Gehäuse

UNI EN 1982 - UNI 5274

Bronze für Schrägzahnräder

UNI EN 1706

Aluminium und Aluminiumlegierungen

UNI EN 1561

Grauguss-Legierungen

UNI EN 1563 2004

Sphäroguss

UNI 3097

Stahl für Lagergleitbahnen

RXO-V 700 - Series

CODE: Example of Order	RX	O	1	704	C1	9.5
WEB: Reference Designation	Maschine 00-M	Centerline Orientation 01-CO	N° of reductions 02-NOR	Size 03-SIZE	Shaft arrangement 04-SA	Reduction ratio 05-IR

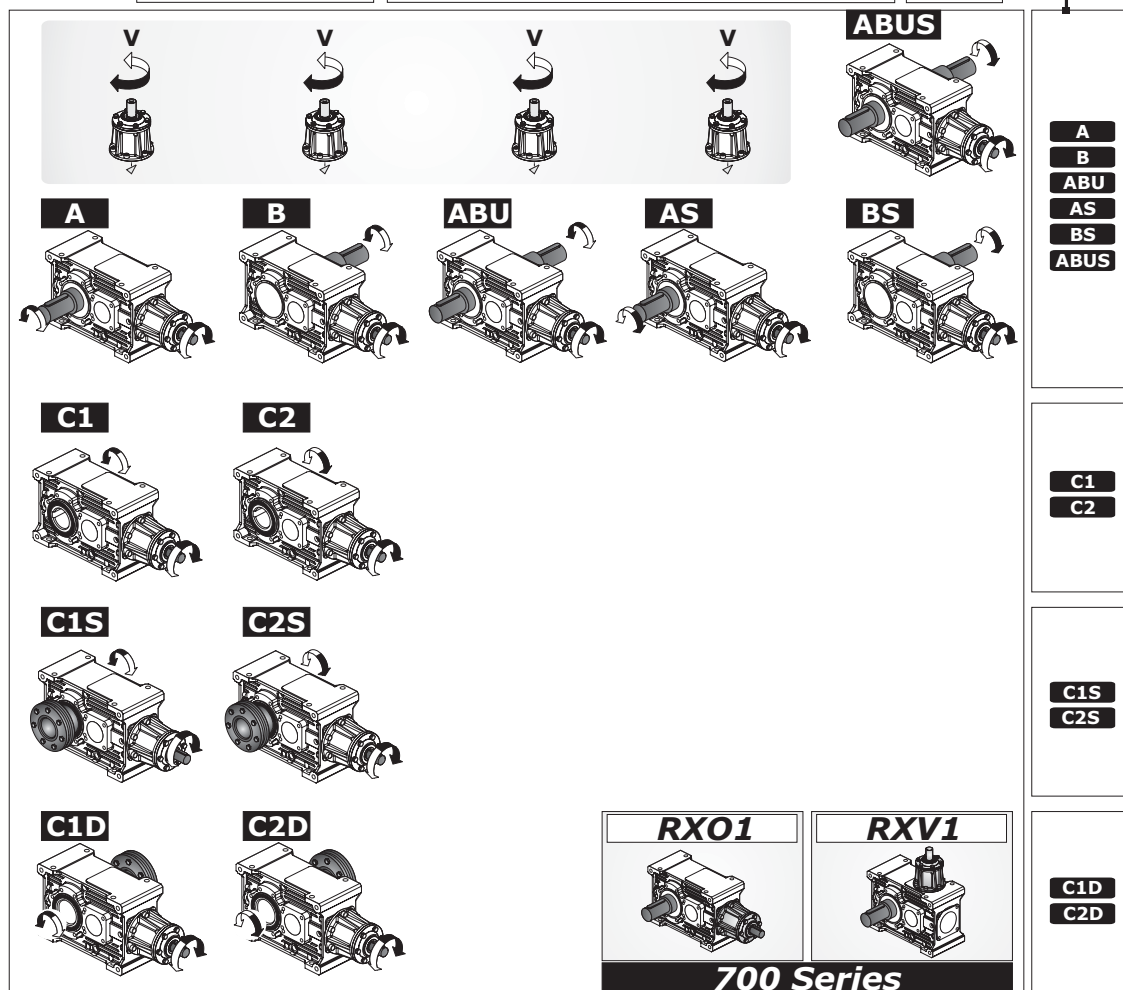
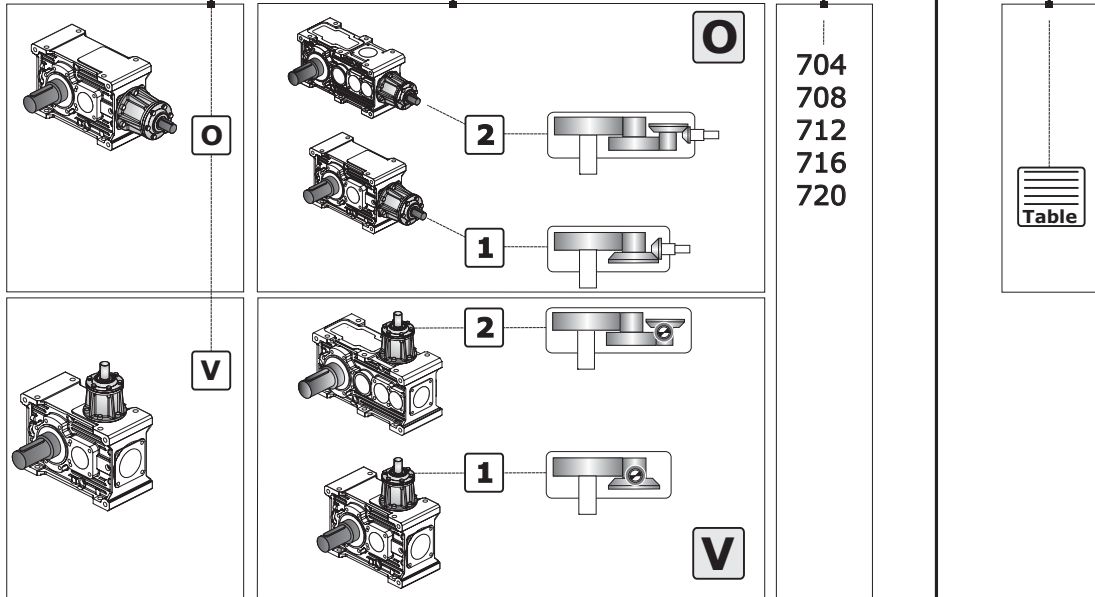

RXO-V 700 - Series

PAM	63	G	-	-	-	-	C	-	M1	-	-	-
Input Version Main	Input Shaft Main	IEC type and Input Shaft Main	Input Version Secondary	Input Shaft Secondary	IEC type and Input Shaft Secondary	Backstop	Output Shaft	Mounting position output Flange	Mounting positions	Options	Additional shaft extension	Position Terminal Box
06-IVM	07-ISM	08-IECTM	09-IVS	10-ISS	11-IECTS	13-BSTOP	16-OS	17-MPOF	18-MP	19-OPT	20-ASE	21-PMT



O	ECE	ECE	PAM.G.R	PAM.D	PAM.
	PAM.D	PAM.G.R	PAM.D	PAM.	
	PAM.	ECE	PAM.G.R	PAM.D	PAM.
V	ECE	ECE	PAM.G.R	PAM.D	PAM.
	PAM.G.R	ECE	PAM.D	PAM.	
	PAM.	ECE	PAM.G.R	PAM.D	PAM.





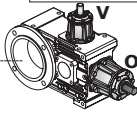
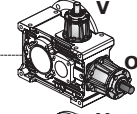
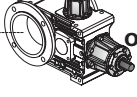

 A richiesta
 On request
 Auf Anfrage









M1	PROT	U	1
M2			2
M3			3
M4			4
M5			
M6			

Fs  **C1D-C2D**
Fd  **C1S-C2S**
2F 

N 
D 
FD 

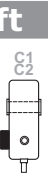
C 

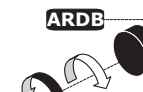
UB 
B  Not supplied
GD 

Left						 ARSB ARSN	
A AS	B BS	ABU ABUS	C1 C2	C1D C2D	C1S C2S	ARDB	ARDN
							

RXO 800 - Series

CODE: Example of Order	RX	O	2	802	C1	24.9
WEB: Reference Designation	Maschine 00-M	Centerline Orientation 01-CO	N° of reductions 02-NOR	Size 03-SIZE	Shaft arrangement 04-SA	Reduction ratio 05-IR

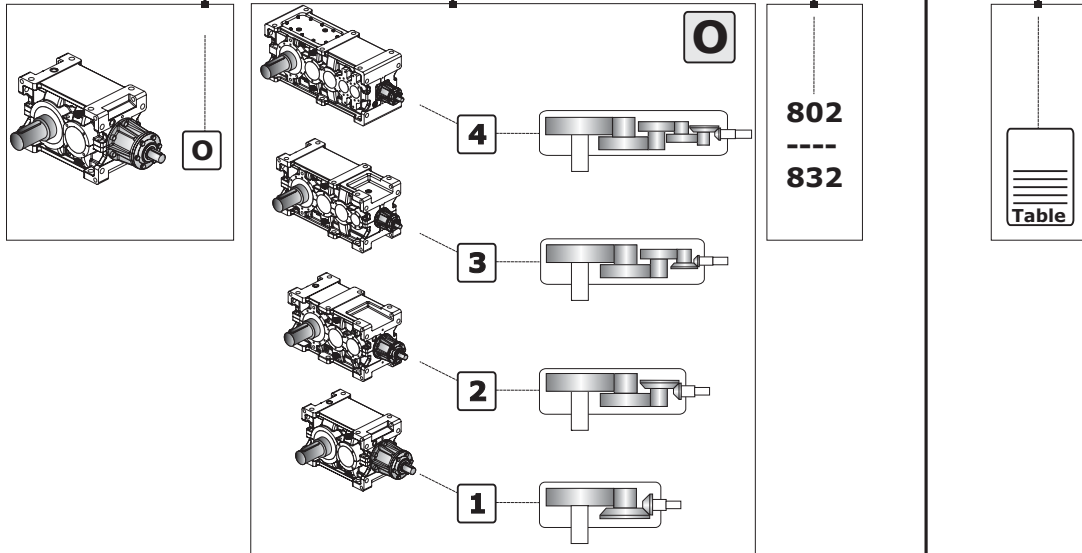

					A B ABU AS BS ABUS
					C1 C2
					C1S C2S
					C1D C2D
RXO1 				RXV1 	
800 Series					

RXO 800 - Series

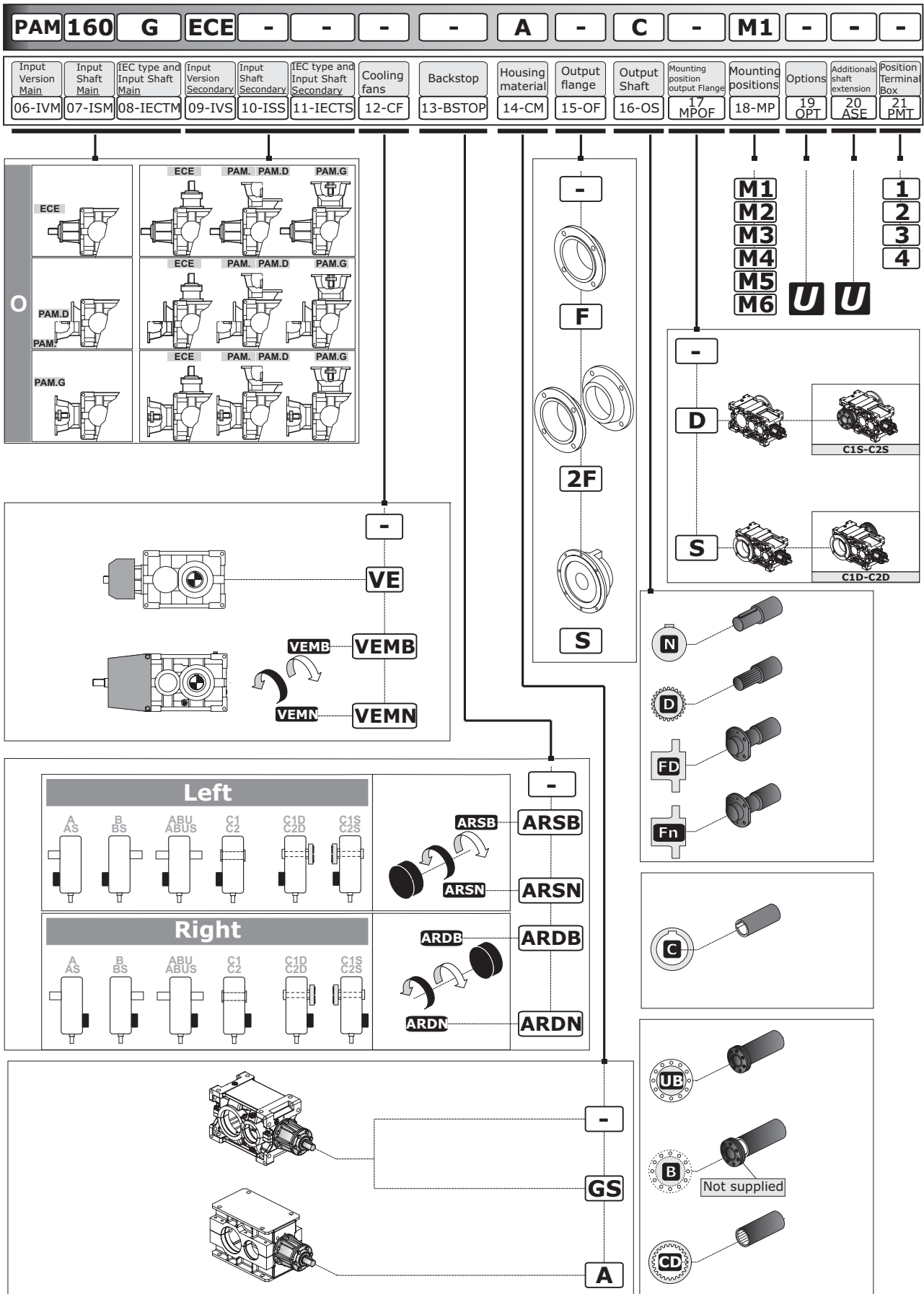

RXV 800 - Series

CODE: Example of Order	RX	V	2	802	B	24.9
	Maschine 00-M	Centerline Orientation 01-CO	N° of reductions 02-NOR	Size 03-SIZE	Shaft arrangement 04-SA	Reduction ratio 05-IR

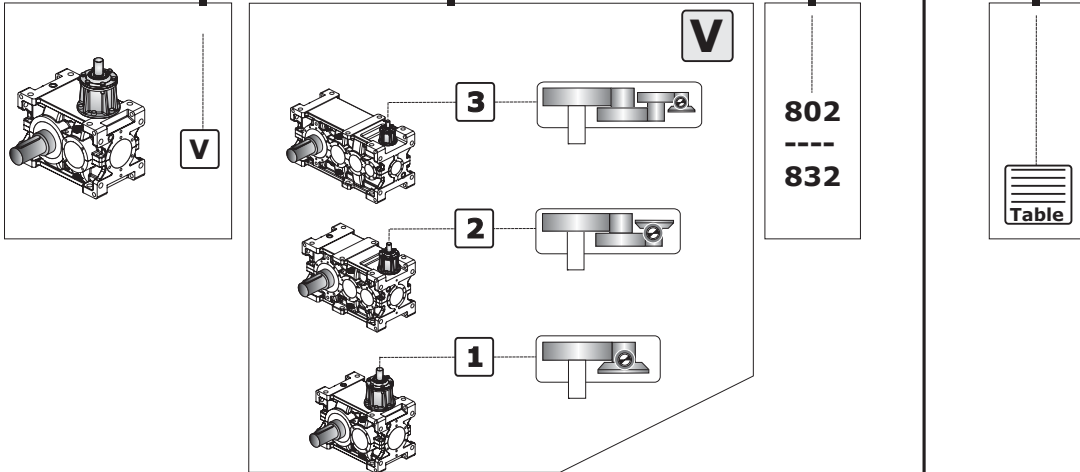

				ABUS	A B ABU AS BS ABUS	
A	B	ABU	AS	BS		
C1	C2					C1 C2
C1S	C2S					C1S C2S
C1D	C2D					C1D C2D
		RX01	RXV1			
800 Series						

RXV 800 - Series

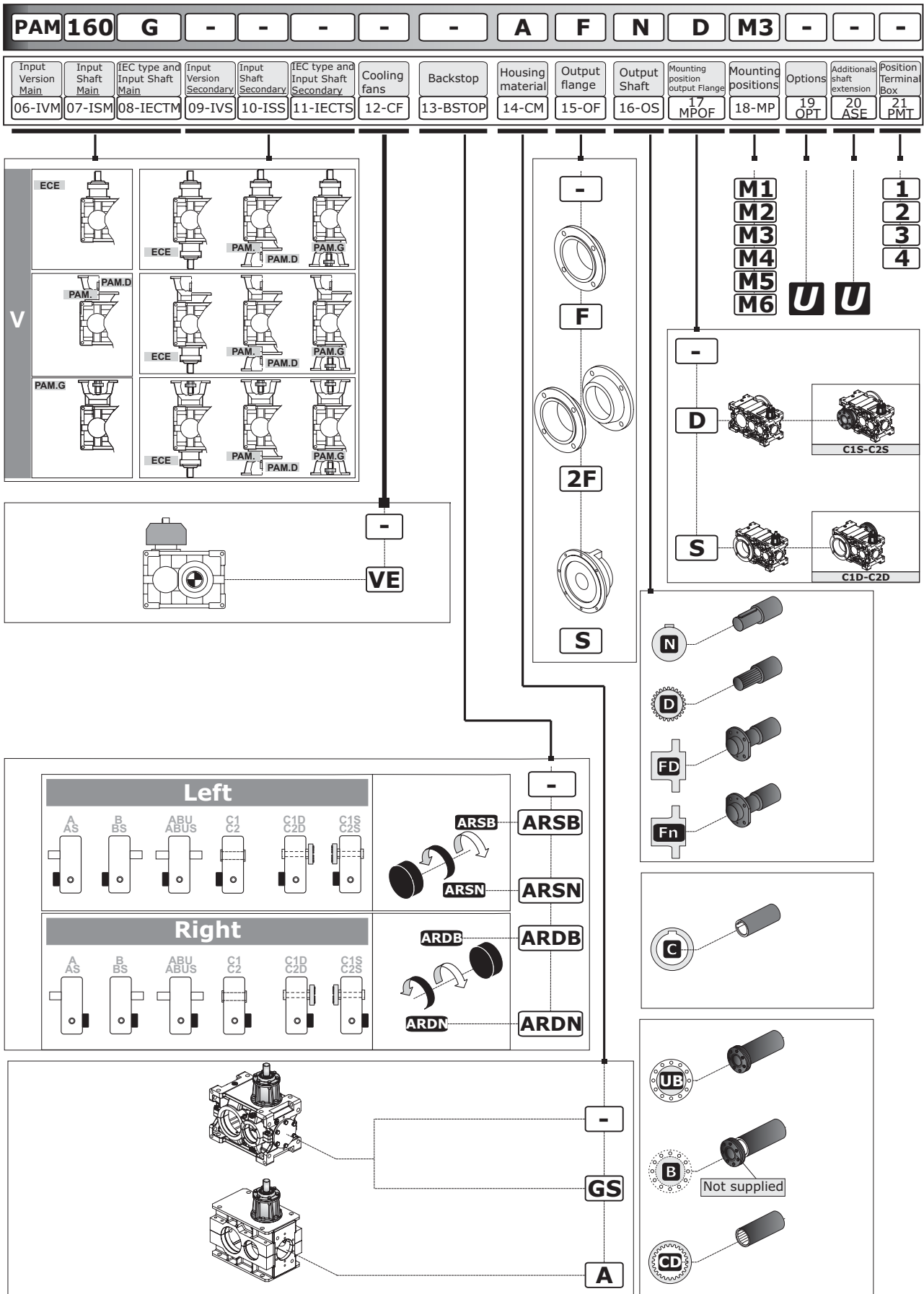

1.7 Designazione

1.7 Designation

1.7 Bezeichnung

00 M - Macchina

M - Maschine

M - Getriebe

RX

01 CO - Posizione Assi

CO - Centerline Orientation

CO - Bauform getriebestufen

RX 700 Series

RX 800 Series

O

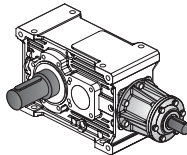

O

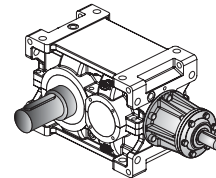

V

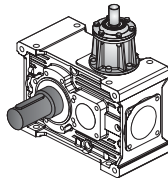

V

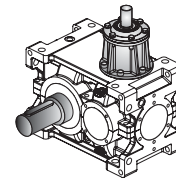

02 NOR - N° Stadi

NOR - N° of reductions

NOR - N° Anzahl der stufen

	RXO-RXV	RXO-RXV	RXO-RXV	RXO
RX 700	1	2	—	—
RX 800	1	2	3	4

03 SIZE - Grandezza

SIZE - Size

SIZE - Größe

	RX 700 Series					RX 800 Series																
	704	708	712	716	720	802	804	806	808	810	812	814	816	818	820	822	824	826	828	830	832	
RXO1																						
RXV1																						—
RXO2	—																					—
RXV2																						
RXO3																						
RXV3																						
RXO4																						
RXV4																						

04 SA - Esecuzione grafica

SA - Shaft arrangement

SA - Grafische Ausführung

05 - SA			
A	B	ABU	
AS	BS	ABUS	
C1	C2		
C1D	C1S		
C2D	C2S		

05 IR - Rapporto di riduzione

IR - Reduction ratio

IR - Übersetzungsverhältnis

(Vedi prestazioni). Tutti i valori dei rapporti sono approssimati. Per applicazioni dove necessita il valore esatto consultare il ns. servizio tecnico.

(See ratings). Ratios are approximate values. If you need exact values for a specific application, please contact our Engineering.

(Siehe "Leistungen"). Bei allen Werten der Übersetzungen handelt es sich um approximative Wertangaben. Bei Applikationen, bei denen die exakte Wertangabe erforderlich ist, muss unser Technischer Kundendienst konsultiert werden.

1.7 Designazione

1.7 Designation

1.7 Bezeichnung

04 SA - Esecuzione grafica

SA - Shaft arrangement

SA - Grafische Ausführung

RXO-V 1
700

				<p>ABUS</p>
A	B	ABU	AS	BS
C1	C2			
C1S	C2S			
C1D	C2D			
		RXO1	RXV1	
700 Series				

N

D

FD

C

UB

B Not supplied

CD

RXO-V 1
800

				<p>ABUS</p>
A	B	ABU	AS	BS
C1	C2			
C1S	C2S			
C1D	C2D			
		RXO1	RXV1	
800 Series				

N

D

FD

Fi

G

UB

B Not supplied

CD

1.7 Designazione

1.7 Designation

1.7 Bezeichnung

04 SA - Esecuzione grafica

SA - Shaft arrangement

SA - Grafische Ausführung

RXO-V 2
700

RXO-V 2
800

1.7 Designazione

1.7 Designation

1.7 Bezeichnung

04 SA - Esecuzione grafica

SA - Shaft arrangement

SA - Grafische Ausführung

RXO-V 3
800

RXO 4
800

1.7 Designazione

1.7 Designation

1.7 Bezeichnung



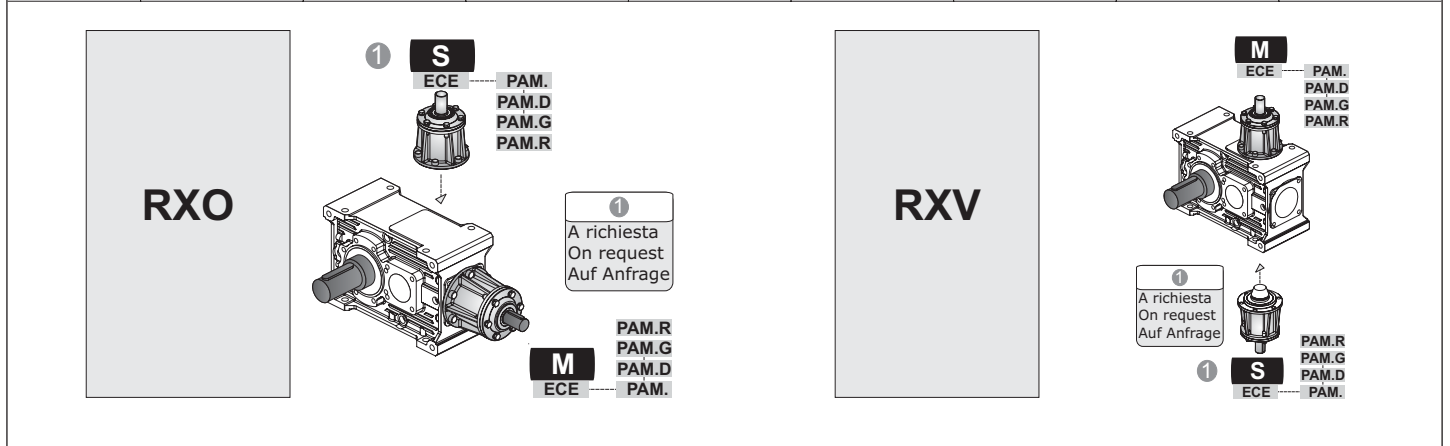

RX 700 Series	M (Entrata Principale/ Main Input /Hauptantrieb)			S (Entrata Secondaria / Secondary Input / Nebenantrieb)				
	06 IVM <small>Versione Entrata Input Version Antriebsausführung</small>	07 ISM <small>Albero Entrata Input Shaft Antriebswelle</small>	08 IECTM <small>Tipo IEC e Albero Entrata IEC type and Input Shaft IEC Typ und Antriebswelle</small>	09 IVS <small>Versione Entrata Input Version Antriebsausführung</small>	10 ISS <small>Albero Entrata Input Shaft Antriebswelle</small>	11 IECTS <small>Tipo IEC e Albero Entrata IEC type and Input Shaft IEC Typ und Antriebswelle</small>		
	ECE	ECE	—	—	ECE	ECE	—	—
	PAM..	PAM	80 90 ...	—	PAM	80 90 ...	—	—
	PAM..G			G			PAM..G	G
	PAM..D			D			PAM..D	D
PAM...R	R			PAM...R			R	

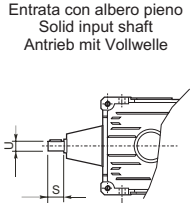
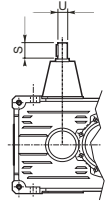

1.7 Designazione

1.7 Designation

1.7 Bezeichnung

RX 700 Series	 <p>ECE Entrata con albero pieno Solid input shaft Antrieb mit Vollwelle</p>		 <p>RXO</p>	 <p>RXV</p>	<p>PAM...</p>  <p>IEC - Con campana senza giunto IEC - Motor bell without coupling IEC - mit Glocke ohne Kupplung</p>	<p>PAM...G</p>  <p>IEC - Con campana e giunto IEC - Motor bell and coupling IEC - mit Glocke und Kupplung</p>	<p>PAM...R</p>  <p>IEC-Con campana e giunto non elastico IEC - Motor bell and coupling not elastic IEC-mit Glocke und Kupplung mit keinem elastischen Teil</p>	U	S	63 (B5)	71 (B5)	80 (B5)	90 (B5)	100 (B5)	112 (B5)	132 (B5)	160 (B5)	180 (B5)	200 (B5)
	RXO1 RXV1	704	14 j6	30															
	708	19 j6	40																
	712	24 j6	50																
	716	28 j6	60									PAM132 G*	PAM160 G*	PAM180 G*					
	720	38 k6	80									PAM132 G*	PAM160 G*	PAM180 G*	PAM200 G*				
RXO2 RXV2	708	14 j6	30																
	712	19 j6	40																
	716	24 j6	50																
	720	28 j6	60									PAM132 G*	PAM160 G*	PAM180 G*					

*Solo PAM...G - forniti con giunto tipo Rotex.

* Only PAM...G - come with Rotex coupling.

* nur PAM...G - Werden sie mit Kupplung Typ Rotex geliefert.



RX 700 Series	<p>PAM...D</p>  <p>IEC - Accoppiamento diretto IEC - Direct coupling IEC - Direkte Passung</p>	
RXO-V1 704 RXO-V2 708	90	24/200 (B5) - 24/140 (B14) - 24/160 - 24/120
	80	19/200 (B5) - 19/120 (B14) - 19/160 - 19/140
	71	14/160 (B5) - 14/200 - 14/140 - 14/120
	63	11/140 (B5) - 11/200 - 11/160 - 11/120
RXO-V1 708 RXO-V2 712	112	28/250 (B5) - 28/160 (B14) - 28/200 - 28/140 - 28/120
	100	28/250 (B5) - 28/160 (B14) 28/200 - 28/140 - 28/120
	90	24/200 (B5) - 24/140 (B14) 24/250 - 24/160 - 24/120
	80	19/200 (B5) - 19/120 (B14) 19/250 - 19/160 - 19/140
	71	14/160 (B5) - 14/250 - 14/200 - 14/140 - 14/120
RXO-V1 712 RXO-V2 716	132	38/300 (B5) - 38/200 (B14) - 38/250
	112	28/250 (B5) - 28/300 - 28/200
	100	28/250 (B5) - 28/300 - 28/200
	90	24/200 (B5) - 24/300 - 24/250
	80	19/200 (B5) - 19/300 - 19/250
RXO-V1 716 RXO-V1 720 RXO-V2 720	132	38/300 (B5) - 38/200 (B14) - 38/250
	112	28/250 (B5) - 28/300 - 28/200
	100	28/250 (B5) - 28/300 - 28/200
	90	24/200 (B5) - 24/300 - 24/250
	80	19/200 (B5)

N.B: Per ulteriori accoppiamenti non previsti a catalogo consultare il ns. servizio tecnico commerciale.

NOTE: For coupling with motors not listed in this catalogue, please contact our Sales Engineers.

HINWEIS: Für weitere, nicht im Katalog enthaltene Passungen, bitten wir Sie sich mit unseren Technischen Kundendienst in Verbindung zu setzen.

Designazione motore elettrico Se è richiesto un motoriduttore completo di motore è necessario riportare la designazione di quest'ultimo. A tale proposito consultare il ns. catalogo dei motori elettrici Electronic Line.	Electric motor designation For applications requiring a gearmotor, motor designation must be specified. To this end, please refer to our Electronic Line electric motor catalogue.	Bezeichnung des Elektromotors Wird ein Getriebemotor komplett mit Elektromotor angefordert, müssen dessen Daten angegeben werden. Diesbezüglich verweisen wir auf unseren Katalog der Elektromotoren "Electronic Line".
---	---	--

1.7 Designazione

1.7 Designation

1.7 Bezeichnung

RX 800 Series	M (Entrata Principale/ Main Input /Hauptantrieb)			CODE GSM	S (Entrata Secondaria / Secondary Input / Nebenantrieb)		
	06 IVM <small>Versione Entrata Input Version Antriebsausführung</small>	07 ISM <small>Albero Entrata Input Shaft Antriebswelle</small>	08 IECTM <small>Tipo IEC e Albero Entrata IEC type and Input Shaft IEC Typ und Antriebswelle</small>		09 IVS <small>Versione Entrata Input Version Antriebsausführung</small>	10 ISS <small>Albero Entrata Input Shaft Antriebswelle</small>	11 IECTS <small>Tipo IEC e Albero Entrata IEC type and Input Shaft IEC Typ und Antriebswelle</small>
	ECE	ECE	—		ECE	ECE	—
	PAM..	PAM	80		PAM..	PAM	80
	PAM..G				90		
PAM..D	...		D	PAM..D	...		D

RXO	RXV
------------	------------

S
ECE
PAM.
PAM.G
PAM.D

M
ECE
PAM.G
PAM.D
PAM.

M
ECE
PAM.
PAM.G
PAM.D

S
PAM.D
PAM.G
ECE
PAM.

1.7 Designazione

1.7 Designation

1.7 Bezeichnung

<p>RX 800 Series</p> <p>ECE</p> <p>Entrata con albero pieno Solid input shaft Antrieb mit Vollwelle</p>				<p>PAM...</p> <p>IEC - Con campana senza giunto IEC - Motor bell without coupling IEC - mit Glocke ohne Kupplung</p>		<p>PAM...G</p> <p>IEC - Con campana e giunto IEC - Motor bell and coupling IEC - mit Glocke und Kupplung</p>		<p>PAM...D</p> <p>IEC - Accoppiamento diretto IEC - Direct coupling IEC - Direkte Passung</p>													
				U	S	71 B5	80 B5	90 B5	100 B5	112 B5	132 B5	160 B5	180 B5	200 B5	225 B5	250 B5	280 B5	315 B5	355 B5		
RXO1 RXV1	802	28 j6	50																		
	804	32 k6	56																		
	806	35 k6	63																		
	808	40 k6	70																		
	810	45 k6	80																		
	812	50 k6	90																		
	814	55 m6	100																		
	816	60 m6	112																		
	818	70 m6	125																		
	820	80 m6	140																		
822	90 m6	160																			
824	100 m6	180																			
A richiesta / On request / Auf Anfrage																					
RXO2 RXV2	802	22 j6	40																		
	804	24 j6	45																		
	806	28 j6	50																		
	808	32 k6	56																		
	810	35 k6	63																		
	812	40 k6	70																		
	814	45 k6	80																		
	816	50 k6	90																		
	818	55 m6	100																		
	820	60 m6	112																		
	822	70 m6	125																		
	824	80 m6	140																		
	826	90 m6	160																		
828	100 m6	180																			
830	110 m6	200																			
A richiesta / On request / Auf Anfrage																					
RXO3 RXV3	802	18 j6	32																		
	804	20 j6	36																		
	806	22 j6	40																		
	808	24 j6	45																		
	810	28 j6	50																		
	812	32 k6	56																		
	814	35 k6	63																		
	816	40 k6	70																		
	818	45 k6	80																		
	820	50 k6	90																		
	822	55 m6	100																		
	824	60 m6	112																		
	826	70 m6	125																		
828	80 m6	140																			
830	90 m6	160																			
832	100 m6	180																			
A richiesta / On request / Auf Anfrage																					
RXO4	802	14 j6	30	D	D	D															
	804	14 j6	30	D	D	D															
	806	19 j6	40	D	D	D	D	D													
	808	19 j6	40	D	D	D	D	D													
	810	24 j6	50		D	D	D	D	D												
	812	24 j6	50		D	D	D	D	D												
	814	28 j6	60			D	D	D	D												
816	28 j6	60			D	D	D	D													

Designazione motore elettrico
Se è richiesto un motoriduttore completo di motore è necessario riportare la designazione di quest'ultimo. A tale proposito consultare il ns. catalogo dei motori elettrici Electronic Line.

Electric motor designation
For applications requiring a gearmotor, motor designation must be specified. To this end, please refer to our Electronic Line electric motor catalogue.

Bezeichnung des Elektromotors
Wird ein Getriebemotor komplett mit Elektromotor angefordert, müssen dessen Daten angegeben werden. Diesbezüglich verweisen wir auf unseren Katalog der Elektromotoren "Electronic Line".

1.7 Designazione

1.7 Designation

1.7 Bezeichnung

12 CF - Ventole di raffreddamento

CF - Cooling fans

CF - Kühllüfterräder

RX 700 Series		Non disponibile Not available Nicht verfügbar
----------------------	--	---

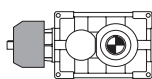
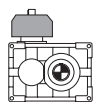
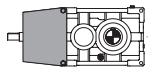
RX 800 Series	—	 	
	Senza Ventola Without Coolings Fan Ohne Kühllüfterräder		

Applicabilità / Application / Applikationsmöglichkeiten																
RXO1	VEMB VEMN	Size	802	804	806	808	810	812	814	816	818	820	822	824	826	828
		ir max	—	10,7	11,7	11,9	11,2	11,7	12,9	10,9	10,8	A richiesta On request Auf Anfrage		—		
RXO1 RXV1	VE	Size	802	804	806	808	810	812	814	816	818	820	—			
		ir	tutti / all / alles													

Applicabilità / Application / Applikationsmöglichkeiten																
RXO2	VEMB VEMN	Size	802	804	806	808	810	812	814	816	818	820	822	824	826	828
		ir max	—	45,3	46,0	45,9	44,1	46,8	52,5	46,1	50,9	A richiesta On request Auf Anfrage				
RXO2 RXV2	VE	Size	802	804	806	808	810	812	814	816	818	820	—			
		ir	tutti / all / alles													

Applicabilità / Application / Applikationsmöglichkeiten													
RXO3 RXV3 RXO4	VEMB VEMN VE	Non disponibile Not available Nicht verfügbar											

ir max = rapporto più alto consentito, oltre non è possibile eseguire l' applicazione
 Ir max= highest ratio available , up to that the application is not possible
 Ir max =höchstmögliches Verhältnis, darüber hinaus ist die Anwendung nicht möglich

 **VEM** - Ventola maggiorata
 Questa esecuzione garantisce un ottimale resa termica . Le geometrie della ventola e del convogliatore dell'aria sono state studiate seguendo il profilo del corpo del riduttore a cui vengono applicate, la progettazione è stata eseguita conformemente a parametri aerodinamici evoluti.

 **VEM** - Big fan
 This version ensures optimal thermal performance. The geometry of the fan and air conveyor were studied following the profile of the housing to which they are applied, the design was carried out in accordance with advanced aerodynamic parameters.

 **VEM** - Vollgebläse. Diese Version gewährleistet eine optimale thermische Leistung. Die Geometrie des Lüfters und des Luftförderers wurden dem jeweiligen Getriebegehäuse angepasst mit dem sie verwendet werden; die Planung entspricht fortschrittlichen aerodynamischen Parametern.

1 - Sono normalmente applicate su riduttori con un solo senso di rotazione. Indicare nella richiesta il senso di rotazione riferendosi all'albero veloce (freccia nera - **VEMN** e freccia bianca **VEMB** , vedere esecuzioni grafiche

1 - They are usually applied on gearboxes with one direction of rotation. Specify the required direction of rotation referring to input shaft (black arrow - **VEMN** and white arrow - **VEMB**, see the graphic executions)

1 - Sie werden üblicherweise bei Getrieben mit einer Drehrichtung verwendet. Geben Sie die gewünschte Drehrichtung in Bezug auf die Antriebswelle an (schwarzer Pfeil - **VEMN** und weißer Pfeil **VEMB**, siehe grafische Darstellung)

2 - Non è possibile fornire la ventola su tutti i rapporti di riduzione proposti a catalogo - per applicabilità vedere la tabella.

2 - Not possible to supply the fan on all the ratios available in the catalog - See the table for applicability.

2 - Der Lüfter kann nicht für alle Getriebeübersetzungen, die im Katalog aufgelistet sind, geliefert werden - Anwendbarkeit gemäß Tabelle.

3 - Per un utilizzo bidirezionale, contattare il nostro ufficio tecnico.

3 - To be used in a bidirectional service, please contact our technical department.

3 - Für eine bidirektionale Anwendung, wenden Sie sich bitte an unsere technische Abteilung.

4 - Disponibile solo con materiale carcassa in G-GS.

4 - Available only with housing material - G-GS.

4 - Verfügbar nur mit Gehäusematerial - G-GS.

13 BSTOP - Antiretro

Hanno adeguata capacità di carico rapportata alle prestazioni del riduttore. Sono montati direttamente sugli alberi pignoni. La lubrificazione è fornita dall'olio del riduttore salvo forme costruttive particolari. L'inversione del senso libero avviene molto semplicemente dall'esterno ruotando le ruote libere di 180°.

Indicare nella richiesta il senso di rotazione libero necessario riferendosi all'albero lento (freccia nera e bianca, vedere esecuzioni grafiche nelle pagine dimensionali).

BSTOP - Backstop

Backstops are supplied with appropriate load capacity for gear unit rating. They are fitted directly on the pinion shafts. Lubrication is provided by gear unit oil (except for some special gear unit configurations). Free rotation is easily reversed by rotating the free wheels through 180° with no need to disassemble the unit.

Specify the required direction of free rotation as viewed from output shaft end (black and white arrow, see shaft arrangements in dimension pages).

BSTOP - Rücklaufsperr

Sie verfügen über eine den Getriebeleistungen angemessene Belastungskapazität. Sie werden direkt auf die Ritzelwellen montiert. Die Schmierung wird, mit Ausnahme besonderer Bauformen, durch das Getriebeöl gegeben. Die Inversion der freien Drehrichtung erfolgt einfach von außen her, indem die Freiläufe um 180° gedreht werden.

In der Anfrage muss unter Bezugnahme auf die Antriebswelle die erforderliche Richtung der freien Drehung angegeben werden (schwarzer und weißer Pfeil, siehe grafische Ausführungen auf den Seiten mit Maßangaben).

	—	Senza Antiretro Without Backstop Ohne Rücklaufsperr
Posizione antiretro a sinistra Backstop on the left Position Rücklaufsperr links	ARSB	Rotazione libera freccia bianca (B) Free rotation - white arrow (B) Freie Drehung - weißer Pfeil (B)
	ARSN	Rotazione libera freccia nera (N) Free rotation - black arrow (N) Freie Drehung - schwarzer Pfeil (N)
Posizione antiretro a destra Backstop on the right Position Rücklaufsperr rechts	ARDB	Rotazione libera freccia bianca (B) Free rotation - white arrow (B) Freie Drehung - weißer Pfeil (B)
	ARDN	Rotazione libera freccia nera (N) Free rotation - black arrow (N) Freie Drehung - schwarzer Pfeil (N)

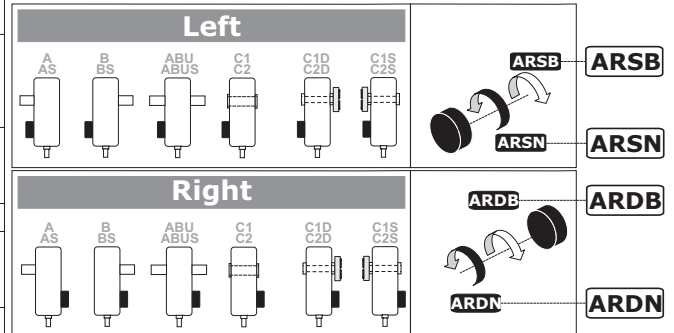

		Applicabilità Application Applikationsmöglichkeiten																				
		RX 700 Series					RX 800 Series															
		704	708	712	716	720	802	804	806	808	810	812	814	816	818	820	822	824	826	828	830	832
RXO 1																						
RXV 1																						
RXO 2		—																				
RXV 2																						
RXO 3																						
RXV 3																						
RXO 4																						
RXV 4																						

RX 800 Series	RXO1 - RV1					
Applicabilità antiretro Application backstop Applikationsmöglichkeiten Rücklaufsperr	ESECZIONI GRAFICHE / SHAFT ARRANGEMENTS / GRAFISCHE AUSFÜHRUNGEN					
	A AS	B BS	ABU ABUS	C1 C2	C1D C2D	C1S C2S
—						
ARSB - ARSN	—		not shaft FD-Fn			—
ARDB - ARDN		—			—	

RX 800 Series	RXO2 - RXV2 RXO3 - RV3 RX O4					
Applicabilità antiretro Application backstop Applikationsmöglichkeiten Rücklaufsperr	ESECZIONI GRAFICHE / SHAFT ARRANGEMENTS / GRAFISCHE AUSFÜHRUNGEN					
	A AS	B BS	ABU ABUS	C1 C2	C1D C2D	C1S C2S
—						
ARSB - ARSN						
ARDB - ARDN						

1.7 Designazione

1.7 Designation

1.7 Bezeichnung

14 CM - Materiale carcassa

CM - Housing material

CM - Gehäusematerial

RX 700 - Series

		RXO1 - RXV1 RXO2 - RXV2				
Materiale carcassa / Housing material Gehäusematerial		704	708	712	716	720
Ghisa meccanica / Engineering cast iron Maschinenguss	G					

RX 800 - Series

		RXO1 - RXV1																
Materiale carcassa / Housing material Gehäusematerial		802	804	806	808	810	812	814	816	818	820	822	824	826	828	830	832	
Ghisa meccanica / Engineering cast iron Maschinenguss	G	"Standard"											—					
Ghisa sferoidale / Spheroidal cast iron Sphäroguss	GS	"On request"											"Std"	—				
Acciaio / Steel / Stahl	A	"On request"											—					

		RXO2 - RXV2																
Materiale carcassa / Housing material Gehäusematerial		802	804	806	808	810	812	814	816	818	820	822	824	826	828	830	832	
Ghisa meccanica / Engineering cast iron Maschinenguss	G	"Standard"											—					
Ghisa sferoidale / Spheroidal cast iron Sphäroguss	GS	"On request"											"Std"	—				
Acciaio / Steel / Stahl	A	"On request"											"Std"	—				

		RXO3 - RXV3																
Materiale carcassa / Housing material Gehäusematerial		802	804	806	808	810	812	814	816	818	820	822	824	826	828	830	832	
Ghisa meccanica / Engineering cast iron Maschinenguss	G	"Standard"											—					
Ghisa sferoidale / Spheroidal cast iron Sphäroguss	GS	"On request"											"Std"	—				
Acciaio / Steel / Stahl	A	"On request"											"Std"	—				

		RXO4															
Materiale carcassa / Housing material Gehäusematerial		802	804	806	808	810	812	814	816	818	820	822	824	826	828	830	832
Ghisa meccanica / Engineering cast iron Maschinenguss	G	"Standard"									—						
Ghisa sferoidale / Spheroidal cast iron Sphäroguss	GS	"On request"									—						
Acciaio / Steel / Stahl	A	"On request"									—						

1.7 Designazione

15 OF - Flangia Uscita

Sono previste flange da impiegare qualora si desideri il fissaggio diretto del riduttore alla macchina.

F - La soluzione è molto compatta, la battuta dell'albero lento non è modificata rispetto allo standard.

S - La soluzione prevede un allungamento della distanza tra i cuscinetti e della battuta dell'albero lento per fornire maggiore stabilità all'intera struttura.

1.7 Designation

OF - Output Flange

Output flanges are available for flange-mount configuration. This provides a compact design;

F - *standard output shaft shoulder dimensions are unchanged.*

S - *The solution provides a lengthening of the distance between the bearings and the outputshaft to provide greater stability to the whole structure.*

1.7 Bezeichnung

OF - Flansche am Abtrieb

Es sind Flanschen vorgesehen, die dann einzusetzen sind, wenn eine direkte Befestigung des Getriebes an der Maschine gewünscht wird. Bei dieser Lösung handelt es sich um eine sehr kompakte Form, der Abtriebswellenansatz ist dem standardmäßigen Ansatz gleich.

S - Die Lösung bietet eine Verlängerung der Abstand zwischen den Lagern und der Abtriebwelle, um eine größeren Stabilität der gesamten Struktur bereitzustellen.

RX 700 Series

Per ulteriori informazioni vedere - 17 - MPOF
For more details, please read - 17 - MPOF
Sie können Weitere Informationen siehe - 17 - MPOF

RX 800 Series

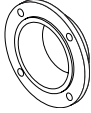
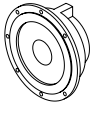
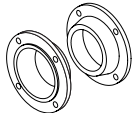
—	F	S	2F
Senza Flangia <i>Without Flange</i> Ohne Flansche	Flangia Uscita <i>Output Flange</i> Flansche am Abtrieb	Supportazione flangiata in uscita <i>Flange bearing on the right at output end</i> Geflanschte Lagerung am Abtrieb	Doppia flangia in uscita <i>Double output flange</i> Doppelter Flansch am Abtrieb
			



Applicabilità <i>Application</i> Applikationsmöglichkeiten	Materiale carcassa / <i>Housing material</i> /Gehäusematerial Ghisa / Cast iron / Guss									
	802	804	806	808	810	812	814	816	818	820
RX01 - RV1	—									
RX02 - RXV2										
RX03 - RXV3										
RX04										

Applicabilità <i>Application</i> Applikationsmöglichkeiten	Materiale carcassa / <i>Housing material</i> /Gehäusematerial Acciaio / Steel / Stahl									
	802	804	806	808	810	812	814	816	818	820
RX01 - RXV1	—									
RX02 - RXV2									—	
RX03 - RXV3									—	
RX04										—

1.7 Designazione

16 OS - Estremità uscita

Nessuna indicazione = diametro standard;

diametro opzionale = vedi tabella.

1.7 Designation

OS - Output shaft

No indications = standard diameter;







optional diameter = see table.



1.7 Bezeichnung

OS - Wellenende - Abtrieb

Keine Angabe = Standard-durchmesser

Optionaler durchmesser = siehe Tabelle.

RX 700			 				
	Standard — (N)	Standard — (C)	Optional C...	Standard — (UB) B	Standard CD	Standard D	Standard FD
704	— (N - Ø 24xL50)	— (C - Ø 24)	C28 (Ø 28)	— (UB - Ø 25) B (Ø 25)	(28 x 25 DIN5482)	(35 x 31 DIN5482)	(35 x 31 DIN5482)
708	— (N - Ø 32xL60)	— (C - Ø 32)	C30 (Ø 30) C35 (Ø 35)	— (UB - Ø 35) B (Ø 35)	(35 x 31 DIN5482)	(40 x 36 DIN5482)	(40 x 36 DIN5482)
712	— (N - Ø 42xL80)	— (C - Ø 42)	C40 (Ø 40) C45 (Ø 45)	— (UB - Ø 45) B (Ø 45)	(40 x 36 DIN5482)	(58 x 53 DIN5482)	(58 x 53 DIN5482)
716	— (N - Ø 55xL100)	— (C - Ø 55)	C50 (Ø 50)	— (UB - Ø 55) B (Ø 55)	(50 x 45 DIN5482)	(FIAT 60)	(FIAT 60)
720	— (N - Ø 70xL125)	— (C - Ø 70)	C60 (Ø 60)	— (UB - Ø 70) B (Ø 70)	(70 x 64 DIN5482)	(FIAT 70)	(FIAT 70)

RX02	712
 	571
Nei rapporti contrassegnati non è disponibile la versione uscita con albero cavo - "C45" / Hollow output shaft "C45" not available for ratios / Bei den gekennzeichneten Übersetzungsverhältnissen ist die Version „Abtrieb mit Hohlwelle "C45" nicht verfügbar	

N	Sporgente Integrale / Output shaft / Vollwelle
C	Albero Cavo / Hollow Shaft / Holwelle
UB - B	Albero cavo con unità di bloccaggio / Hollow output shaft with shrink disc / Hohlwelle mit Schrumpfscheibe
CD	Albero lento cavo scanalato / Splined hollow shaft / Verzahnte Hohlwelle
D	Estremità albero lento scanalato senza flangia brocciata / Splined output shaft without broached flange / Abtriebswelle mit Keilende ohne geräumtem Flansch
FD	Estremità scanalata albero lento flangia brocciata / Splined output shaft and broached flange / Abtriebswelle mit Keilende und geräumtem Flansch
F1...F9	Estremità scanalata albero lento con giunto dentato flangiato / Splined output shaft with flanged splined coupling / Abtriebswelle mit Keilende mit geflanschter Klauen kupplung
F101...F108	Estremità scanalata albero lento con giunto flangiato a rulli bombati / Splined output shaft with flanged barrel rollers coupling / Abtriebswelle mit Keilende mit geflanschter Tonnenrollen kupplung

1.7 Designazione









1.7 Designation

1.7 Bezeichnung





16 OS - Estremità uscita

OS - Output shaft





OS - Wellenende - Abtrieb

RX 800			 					
	Standard N	Standard C	Standard UB B	Standard CD	Standard D	Standard FD	Standard F...	Standard F1..
802	(∅ 60xL112)	(∅ 60)	(∅ 60)	(60 x 55 DIN5482)	(FIAT 60)	(FIAT 60)	—	
804	(∅ 70xL125)	(∅ 70)	(∅ 70)	(70 x 64 DIN5482)	(FIAT 70)	(FIAT 70)	—	
806	(∅ 80xL140)	(∅ 80)	(∅ 80)	(80 x 74 DIN5482)	(FIAT 80)	(FIAT 80)	—	
808	(∅ 90xL160)	(∅ 90)	(∅ 90)	(90 x 84 DIN5482)	(FIAT 95)	(FIAT 95)	F1	F101
810	(∅ 100xL180)	(∅ 100)	(∅ 100)	(100 x 94 DIN5482)	(D. 105 DIN 5480)	(D. 105 DIN 5480)	F1	F101
812	(∅ 110xL200)	(∅ 110)	(∅ 110)	(110 x 3 x 35 DIN5480)	(D. 110 DIN 5480)	(D. 110 DIN 5480)	F2	F102
814	(∅ 125xL225)	(∅ 125)	(∅ 125)	(120 x 5 x 22 DIN5480)	(D. 130 DIN 5480)	(D. 130 DIN 5480)	F3	F103
816	(∅ 140xL250)	(∅ 140)	(∅ 140)	(140 x 5 x 26 DIN5480)	(D. 140 DIN 5480)	(D. 140 DIN 5480)	F4	F104
818	(∅ 160xL280)	(∅ 160)	(∅ 160)	(160 x 5 x 30 DIN5480)	(D. 160 DIN 5480)	(D. 160 DIN 5480)	F5	F105
820	(∅ 180xL315)	(∅ 180)	(∅ 180)	(180 x 8 x 21 DIN5480)	(D. 180 DIN 5480)	(D. 180 DIN 5480)	F6	F106
822	(∅ 200xL355)	(∅ 200)	(∅ 200)	—	(D. 200 DIN 5480)	(D. 200 DIN 5480)	F7	F107
824	(∅ 220xL400)	(∅ 220)	(∅ 220)	—	(D. 220 DIN 5480)	—	F8	F108
826	(∅ 250xL450)	(∅ 250)	(∅ 250)	—	(D. 250 DIN 5480)		F9	F108
828	(∅ 280xL500)	(∅ 280)	(∅ 280)	—	—		On request	On request
830	(∅ 320xL500)	(∅ 320)	(∅ 320)	—	—	—	—	—
832	(∅ 360xL560)	(∅ 360)	(∅ 360)	—	—	—	—	—

Per ulteriori informazioni vedere **SEZIONE T** / For more details, please read **SECTION T** / Sie können Weitere Informationen siehe **ABSCHNITT T**

RXO 2	802	804	806	808	810	812	814	816	818	820	822	824	826	828	830	832
    	107 118	107 118	124	Ok! all	111 123	105 117	107 118	107 118	112 124	109 121	123	117 130	118 132	106 118	on request	—

Nei rapporti contrassegnati non è disponibile la versione uscita con albero cavo - "C"- "UB"- "B"- "CD" / Hollow output shaft "C"- "UB"- "B"- "CD" not available for ratios / Bei den gekennzeichneten Übersetzungsverhältnissen ist die Version „Abtrieb mit Hohlwelle "C"- "UB"- "B"- "CD" nicht verfügbar

RXO 3	802	804	806	808	810	812	814	816	818	820	822	824	826	828	830	832
    	631 700	568 629 697	600 661	Ok! All	618 685	621 689	631 700	568 630 697	597 661	589 653	685	689	700	630 697	Ok! All	Ok! All

Nei rapporti contrassegnati non è disponibile la versione uscita con albero cavo - "C"- "UB"- "B"- "CD" / Hollow output shaft "C"- "UB"- "B"- "CD" not available for ratios / Bei den gekennzeichneten Übersetzungsverhältnissen ist die Version „Abtrieb mit Hohlwelle "C"- "UB"- "B"- "CD" nicht verfügbar

1.7 Designazione

1.7 Designation

1.7 Bezeichnung

17 MPOF - Lato Flangia Uscita

MPOF - Mounting Position Output Flange

MPOF - Montageseite Abtriebsflansch

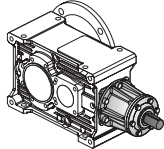
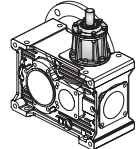
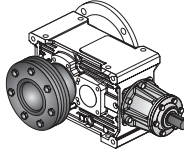
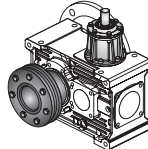
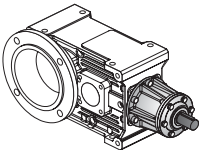
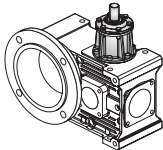
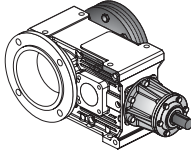
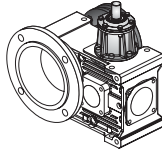
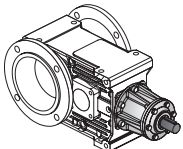
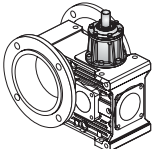
RX 700 Series					
—	Senza Flangia Without Flange Ohne Flansche				
Fd	A-AS-B-BS-ABU-ABUS-C1-C2		Flangia in uscita a destra Output flange on right side Flansch am Abtriebe rechts	C1S - C2S	
					
Fs	A-AS-B-BS-ABU-ABUS-C1-C2		Flangia in uscita a sinistra Output flange on left side Flansch am Abtrieb links	C1D - C2D	
					
2F	A-AS-B-BS-ABU-ABUS-C1-C2		2 Flange in uscita Double output flange Doppelflansch am Abtrieb		
					

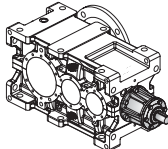
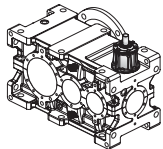
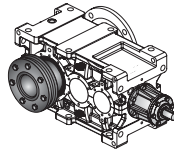
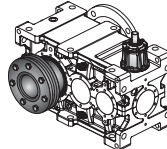
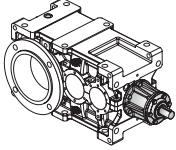
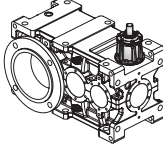
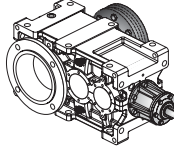
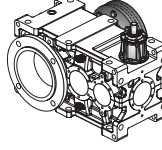
RX 800 Series					
D	B-BS-ABU-ABUS-C1-C2		Flangia in uscita a destra Output flange on right side Flansch am Abtriebe rechts	C1S - C2S	
					
S	A-AS-ABU-ABUS-C1-C2		Flangia in uscita a sinistra Output flange on left side Flansch am Abtrieb links	C1D - C2D	
					

18 MP - Posizioni di montaggio

MP - Mounting positions

MP - Einbaulagen

<p>RX 700 Series</p> <p>RX 800 Series</p>	<p>Per ulteriori informazioni vedere 1.8 For more details, please read 1.8 Sie können Weitere Informationen siehe 1.8</p>
---	---

1.7 Designazione

1.7 Designation

1.7 Bezeichnung

19 OPT-ACC. - Opzioni

OPT-ACC - Options

OPT-ACC. - Optionen

RX 700 RX 800	ACC1	Code	Per ulteriori informazioni vedere SEZIONE T . For more details, please read SECTION T Sie können Weitere Informationen siehe ABSCHNITT T .
		PROT.	
	OPT	VT. SL.	Per ulteriori informazioni vedere SEZIONE U For more details, please read SECTION U Sie können Weitere Informationen siehe ABSCHNITT U

RX 800	ACC.	Code	Per ulteriori informazioni vedere SEZIONE U For more details, please read SECTION U Sie können Weitere Informationen siehe ABSCHNITT U
		RFA. RFW.	

KIT

RX 700 RX 800	ACC1	Code			
		FF	FF - Kit	FF - Kit	FF - Kit
	RR	Kit rosetta di montaggio	Mounting washer kit	Kit Montagescheibe	
	ACC3	BR	Kit bullone di reazione	Torque arm kit	Kit Momentenstütze
Per ulteriori informazioni vedere 1.14 e Sezione T For more details, please read 1.14 and Section T Sie können Weitere Informationen siehe 1.14 und Abschnitt T					

20 ASE - Estremità Supplementare

ASE - Additional Shaft Extension

ASE - Zusätzliches Wellende

RX 700 RX 800	Per ulteriori informazioni vedere SEZIONE U For more details, please read SECTION U Sie können Weitere Informationen siehe ABSCHNITT U
--------------------------	---

21 PMT - Posizioni della Morsettieria

PMT - Position Terminal Box

PMT - Montagposition Klemmenkasten

[2, 3, 4] Posizione della morsettieria del motore se diversa da quella standard (1).

[2, 3, 4] Position of the motor terminal box if different from the standard one (1).

Montageposition Klemmenkasten [2, 3, 4], wenn abweichend von Standardposition [1] (für Motorgetriebe).

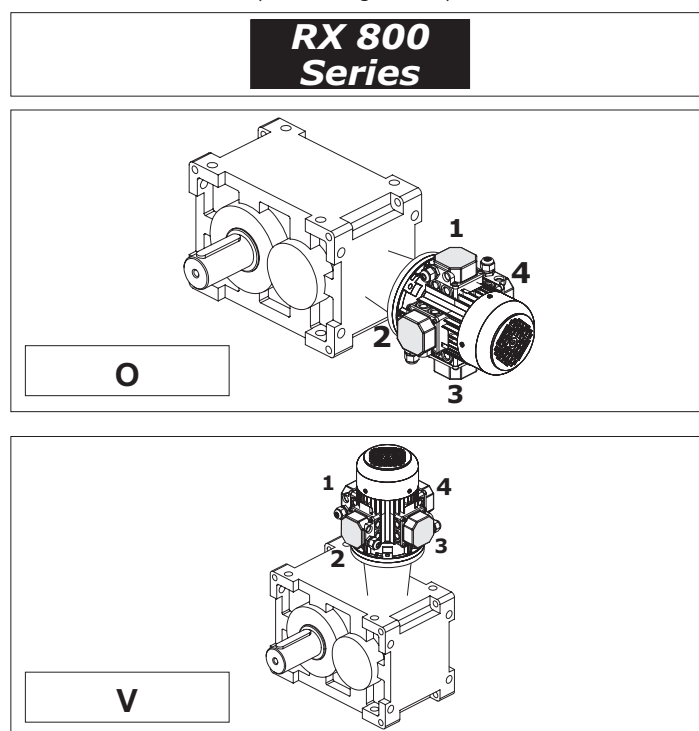
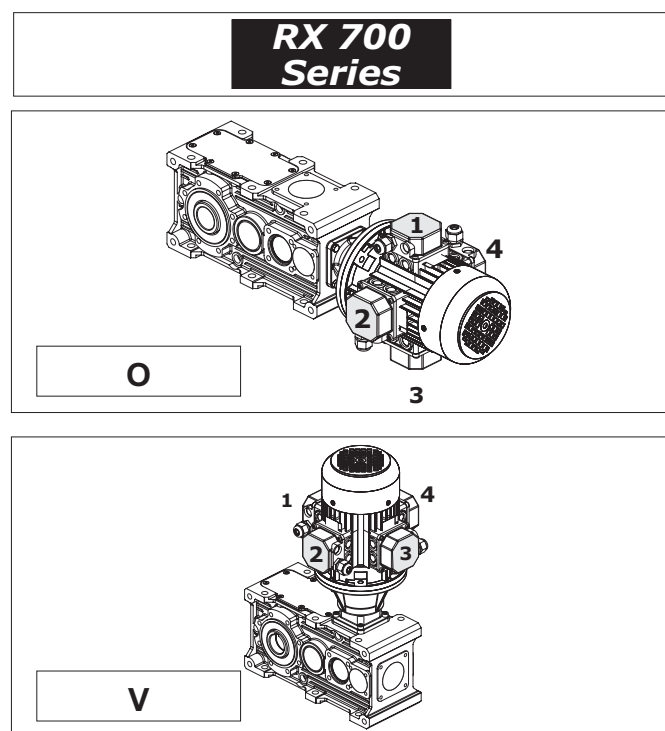

1.8 Lubrificazione

Gli oli disponibili appartengono generalmente a tre grandi famiglie:

- 1) Oli minerali
- 2) Oli sintetici Poli-Alfa-Olefine
- 3) Oli sintetici Poli-Glicole

La scelta più appropriata è generalmente legata alle condizioni di impiego. riduttori non particolarmente caricati e con un ciclo di impiego discontinuo, senza escursioni termiche importanti, possono certamente essere lubrificati con olio minerale.

Nei casi di impiego gravoso, quando i riduttori saranno prevedibilmente caricati molto ed in modo continuativo, con conseguente prevedibile innalzamento della temperatura, è bene utilizzare lubrificanti sintetici tipo polialfaolefine (PAO).

Gli oli di tipo poliglicole (PG) sono da utilizzare strettamente nel caso di applicazioni con forti strisciamenti fra i contatti, ad esempio nelle viti senza fine. Debbono essere impiegati con grande attenzione poiché non sono compatibili con gli altri oli e sono invece completamente miscibili con l'acqua. Questo fenomeno è particolarmente pericoloso poiché non si nota, ma deprime velocemente le caratteristiche lubrificanti dell'olio.

Oltre a questi già menzionati, ricordiamo che esistono gli oli per l'industria alimentare. Questi trovano specifico impiego nell'industria alimentare in quanto sono prodotti speciali non nocivi alla salute. Vari produttori forniscono oli appartenenti a tutte le famiglie con caratteristiche molto simili. Più avanti proponiamo una tabella comparativa.

1.8 Lubrication

Available oils are typically grouped into three major classes:

- 1) Mineral oils
- 2) Poly-Alpha-Olefin synthetic oils
- 3) Polyglycol synthetic oils

Oil is normally selected in accordance with environmental and operating conditions. Mineral oil is the appropriate choice for moderate load, non-continuous duty applications free from temperature extremes.

In severe applications, where gear units are to operate under heavy loads in continuous duty and high temperatures are expected, synthetic Poly-Alpha-Olefin oils (PAO) are the preferred choice.

Polyglycol oils (PG) should only be used in applications involving high sliding friction, as is the case with worm shafts. These particular oils should be used with great care, as they are not compatible with other oils, but are totally mixable with water. The oil mixed with water cannot be told from uncontaminated oil, but will degrade very rapidly.

In addition to the oils mentioned above, there are food-grade oils. These are special oils harmless to human health for use in the food industry. Oils with similar characteristics are available from a number of manufacturers. A comparative overview table is provided at the next pages.

1.8 Schmierung

Die verfügbaren Öle gehören im Allgemeinen drei großen Familien an:

- 1) Mineralöle
- 2) Polyalphaolefine-Synthetiköle
- 3) Polyglykol-Synthetiköle

Die angemessene Wahl ist im Allgemeinen an die Einsatzbedingungen gebunden. Getriebe, die keinen besonders schweren Belastungen ausgesetzt sind und einem unregelmäßigen Einsatzzyklus unterliegen, ohne starke thermische Ausschläge, können problemlos mit Mineralöl geschmiert werden.

Bei einem Einsatz unter harten Bedingungen, d.h. wenn die Getriebe stark und andauernd belastet werden, woraus sich ein sicherer Temperaturanstieg ergibt, sollten Synthetiköle, Typ Polyalphaolefine (PAO), verwendet werden.

Die Öle, Typ Polyglykole (PG), sind ausschließlich für einen Einsatz ausgelegt, bei denen es zu starken Reibungen zwischen den in Kontakt stehenden Elementen kommt, z.B. bei Schnecken. Bei ihrem Einsatz in besondere Aufmerksamkeit erforderlich, da sie nicht mit anderen Ölen kompatibel sind, sich jedoch vollständig mit Wasser vermischen lassen. Diese Tatsache erweist sich daher als besonders gefährlich, da sie sich nicht feststellen lässt, jedoch die Schmiereigenschaften des Öls bereits nach kurzer Zeit unterdrückt.

Über die bereits genannten Öle hinaus, gibt es auch Öle, die speziell für die Lebensmittelindustrie ausgelegt sind. Diese finden demzufolge dort ihren Einsatz, da es sich dabei um spezielle Produkte handelt, die für die Gesundheit unschädlich sind. Die den jeweiligen Familien angehörigen Ölsorten werden von verschiedenen Herstellern angeboten; sie weisen jeweils sehr ähnliche Eigenschaften auf. Auf der folgenden Seite finden Sie eine entsprechende Vergleichstabelle.

Input speed n_1 (min ⁻¹)	Absorbed power (kW)	Lubrication system	Viscosity ISO VG at 40° (cSt)	
			$i \leq 10$	$i > 10$
$2000 < n_1 \leq 5000$	$P < 7.5$	Forced or Oil splash	68	68
	$7.5 \leq P \leq 22$		68	150
	$P > 22$		150	220
$1000 < n_1 \leq 2000$	$P < 7.5$	Forced or Oil splash	68	150
	$7.5 \leq P \leq 37$		150	220
	$P > 37$		220	320
$300 < n_1 \leq 1000$	$P < 15$	Forced Oil splash	68	150
	$15 \leq P \leq 55$	Forced Oil splash	150	220
		Forced Oil splash	220	320
		Forced Oil splash	320	460
$50 < n_1 \leq 300$	$P < 22$	Forced Oil splash	150	220
	$22 \leq P \leq 75$	Forced Oil splash	220	320
		Forced Oil splash	320	460
		Forced Oil splash	460	680

1.8 Lubrificazione

Nel caso di lubrificazione forzata con pompa, qualora siano richieste ISO VG > 220 e/o temperature < 10°C, consultarci.

La tabella è valida per velocità periferiche normali; in caso di velocità > 13m/s, consultarci.

Se la temperatura ambiente T < 0°C ridurre di una gradazione la viscosità prevista in tabella, viceversa aumentarla di una se T > 40°C.

Le temperature ammissibili per gli oli minerali sono:
(-10 = T = 90)°C (fino a 100°C per periodi limitati).

Le temperature ammissibili per gli oli sintetici sono:
(-20 = T = 110)°C (fino a 120°C per periodi limitati).

Per temperature dell'olio esterne a quelle ammissibili per il minerale e per aumentare l'intervallo di sostituzione del lubrificante adottare olio sintetico a base di polialfaolefine.

1.8 Lubrication

In case of forced lubrication by pump, when ISO VG > 220 and/or temperatures < 10°C, are requested, it is advisable to contact us.

The table is valid for normal peripheral speeds; in case of speed > 13 m/s, contact us.

If the environment temperature T < 0°C, decrease viscosity class by one, vice versa increase by one if T > 40°C.

Permissible temperatures for mineral oil are:

(-10 = T = 90)°C, up to 100°C for a short time.

Permissible temperatures for synthetic oil are:
(-20 = T = 110)°C, up to 120°C for a short time.

If the oil temperature is not permissible for mineral oil and for decreasing frequency of oil change, use synthetic oil with polyalphaolefins (PAOs).

1.8 Schmierung

Im Fall einer Zwangsschmierung über eine Pumpe, falls die ISO VG > 220 und/oder Temperaturen < 10°C gefordert werden, setzen Sie sich bitte mit uns in Verbindung.

Die Tabelle ist für normale Umfangsgeschwindigkeiten gültig. Bei Geschwindigkeiten > 13m/s, setzen Sie sich bitte mit uns in Verbindung.

Bei einer Umgebungstemperatur T < 0°C den von der Tabelle vorgesehenen Viskositätsgrad um eine Gradation mindern und, im entgegengesetzten Fall, bei einer Temperatur T > 40°C, um eine anheben.

Für Mineralöle zulässige Temperaturen:

(-10 = T = 90) °C (bis 100°C über begrenzte Zeiträume).

Für Synthetiköle zulässige Temperaturen:

(-20 = T = 110) °C (bis 120°C über begrenzte Zeiträume).

Bei Temperaturen, die diese für Mineralöle zulässigen Werte überschreiten und um die Auswechselzeiten verlängern zu können, sollte Synthetiköl auf Basis von Polyalphaolefinen verwendet werden.

Produttore Manufacturer Hersteller	Oli Minerali Mineral oils Mineralöle			Oli Sintetici Polialfaolefine (PAO) Poly-Alpha-Olefin synthetic oils (PAO) Polyalphaolefine- Synthetiköle (PAO)			Oli Sintetici Poliglicoli (PG) Polyglycol synthetic oils (PG) Polyglykol-Synthetiköle (PG)		
	ISO VG	ISO VG	ISO VG	ISO VG	ISO VG	ISO VG	ISO VG	ISO VG	ISO VG
	150	220	320	150	220	320	150	220	320
AGIP	Blasia 150	Blasia 220	Blasia 320	-	Blasia SX 220	Blasia SX 320	Blasia S 150	Blasia S 220	Blasia S 320
ARAL	Degol BG 150 Plus	Degol BG 220 Plus	Degol BG 320 Plus	Degol PAS 150	Degol PAS 220	Degol PAS 320	Degol GS 150	Degol GS 220	Degol GS 320
BP	Energol GR-XP 150	Energol GR-XP 220	Energol GR-XP 320	Enersyn EPX 150	Enersyn EPX 220	Enersyn EPX 320	Enersyn SG 150	Enersyn SG-XP 220	Enersyn SG-XP 320
CASTROL	Alpha SP 150	Alpha SP 220	Alpha SP 320	Alphasyn EP 150	Alphasyn EP 220	Alphasyn EP 320	Alphasyn PG 150	Alphasyn PG 220	Alphasyn PG 320
CHEVRON	Ultra Gear 150	Ultra Gear 220	Ultra Gear 320	Tegra Synthetic Gear 150	Tegra Synthetic Gear 220	Tegra Synthetic Gear 320	HiPerSYN 150	HiPerSYN 220	HiPerSYN 320
ESSO	Spartan EP 150	Spartan EP 220	Spartan EP 320	Spartan S EP 150	Spartan S EP 220	Spartan S EP 320	Glycolube 150	Glycolube 220	Glycolube 320
KLÜBER	Klüberoil GEM 1-150	Klüberoil GEM 1-220	Klüberoil GEM 1-320	Klübersynth EG 4-150	Klübersynth EG 4-220	Klübersynth EG 4-320	Klübersynth GH 6-150	Klübersynth GH 6-220	Klübersynth GH 6-320
MOBIL	Mobilgear XMP 150	Mobilgear XMP 220	Mobilgear XMP 320	Mobilgear SHC XMP 150	Mobilgear SHC XMP 220	Mobilgear SHC XMP 320	Glygoyle 22	Glygoyle 30	Glygoyle HE320
MOLIKOTE	L-0115	L-0122	L-0132	L-1115	L-1122	L-1132	-	-	-
OPTIMOL	Optigear BM 150	Optigear BM 220	Optigear BM 320	Optigear Synthetic A 150	Optigear Synthetic A 220	Optigear Synthetic A 320	Optiflex A 150	Optiflex A 220	Optiflex A 320
Q8	Goya 150	Goya 220	Goya 320	El Greco 150	El Greco 220	El Greco 320	Gade 150	Gade 220	Gade 320
SHELL	OMALA S2 G 150	OMALA S2 G 220	OMALA S2 G 320	Omala S4 GX 150	Omala S4 GX 220	Omala S4 GX 320	OMALA S4 WE 150	OMALA S4 WE 220	OMALA S4 WE 320
TEXACO	Meropa 150	Meropa 220	Meropa 320	Pinnacle EP 150	Pinnacle EP 220	Pinnacle EP 320	-	Synlube CLP 220	Synlube CLP 320
TOTAL	Carter EP 150	Carter EP 220	Carter EP 320	Carter SH 150	Carter SH 220	Carter SH 320	Carter SY 150	Carter SY 220	Carter SY 320
TRIBOL	1100/150	1100/220	1100/320	1510/150	1510/220	1510/320	800\150	800\220	800\320

Lubrificanti sintetici per uso alimentare / Food-grade synthetic lubricants / Schmiermittel Synthetik für Lebensmittelbereich

AGIP				Rocol Foodlube Hi-Torque 150	—	Rocol Foodlube Hi-Torque 320			
ESSO				—	Gear Oil FM 220	—			
KLÜBER				Klüberoil 4 UH1 N 150	Klüberoil 4 UH1 N 220	Klüberoil 4 UH1 N 320			
MOBIL				DTE FM 150	DTE FM 220	DTE FM 320			
SHELL				Cassida Fluid GL 150	Cassida Fluid GL 220	Cassida Fluid GL 320			

1.8 Lubrificazione

1.8 Lubrication

1.8 Schmierung

Posizioni di montaggio

Mounting positions

Einbaulagen

RX 700 - Series

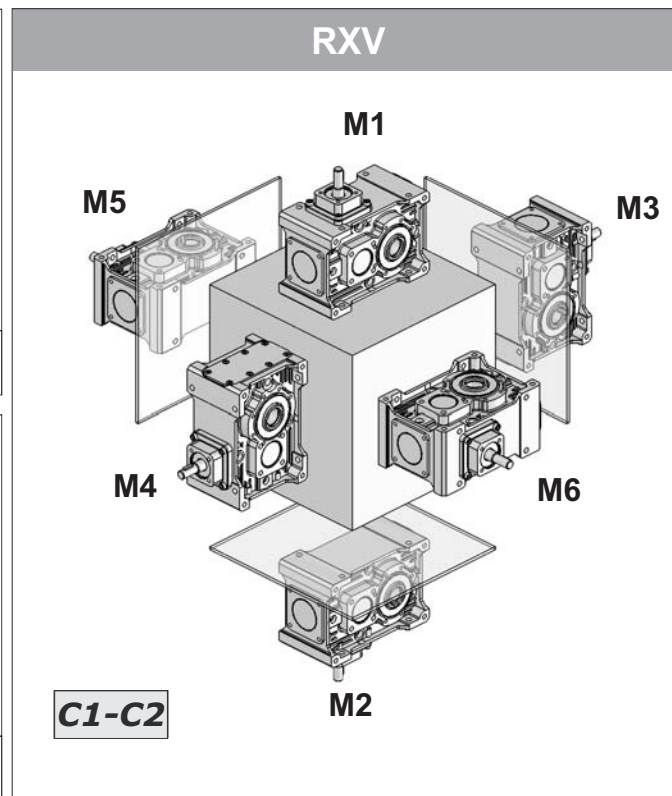
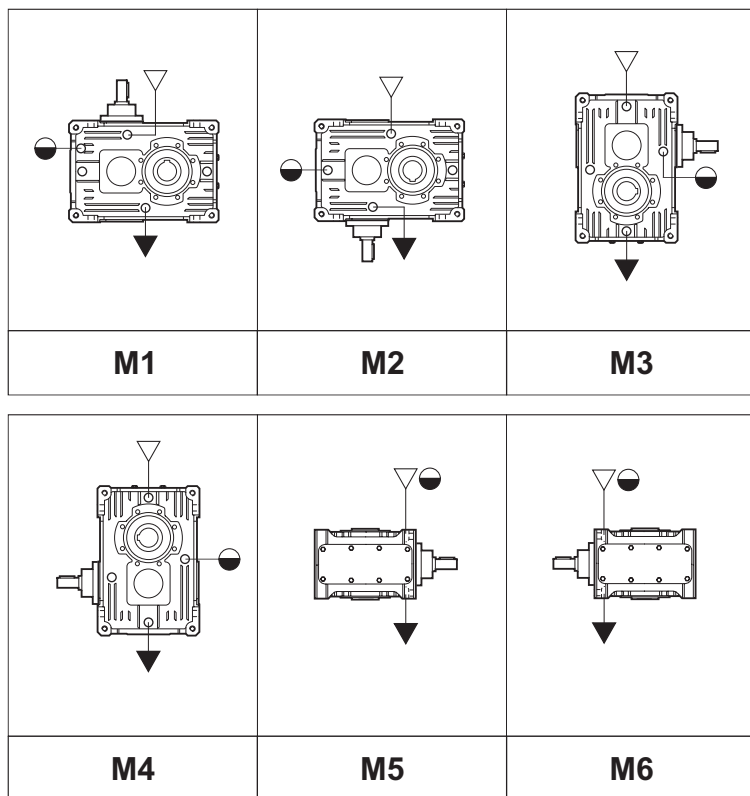
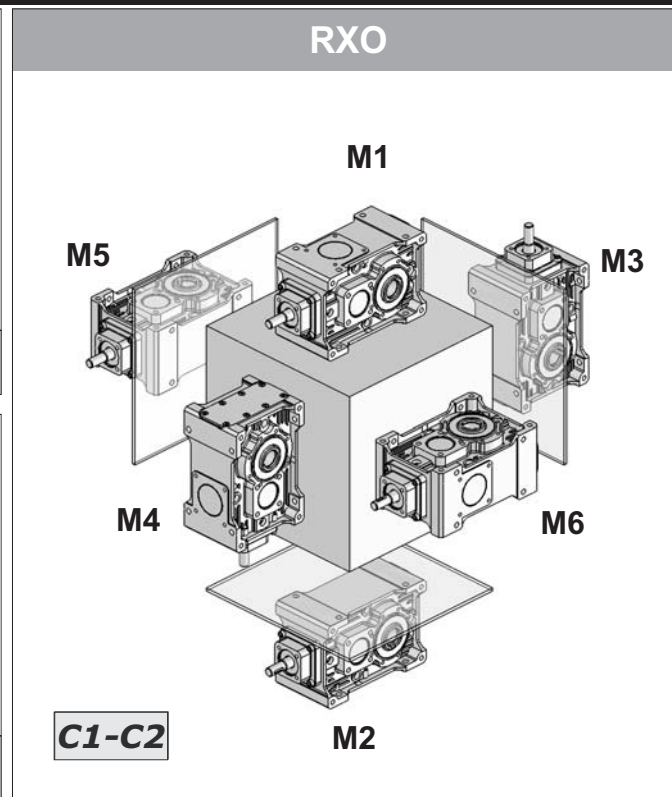
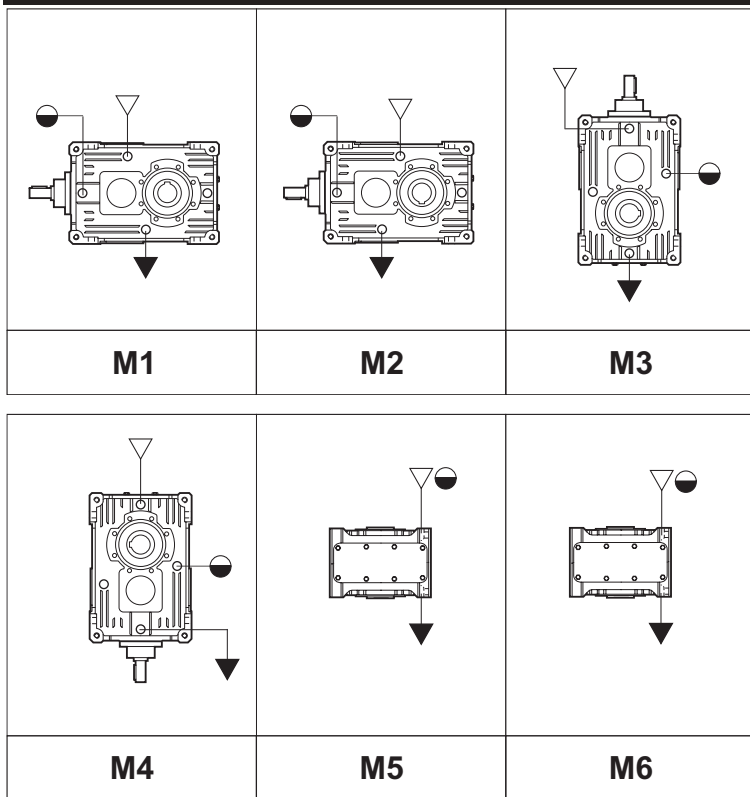

N.B. schema rappresentativo anche per 3 stadi
 NOTE Diagram applies to 3 reduction units as well
 HINWEIS: Schema auch für 3 Stufen gültig

- ▽ Carico / Filler plug / Einfüllschraube
- ▼ Scarico / Drain plug / Ablassschraube
- Livello / Level plug / Schauglas

L'esecuzione grafica rappresentata è la C1-C2.
 Per le altre esecuzioni grafiche vedere sezione POSIZIONI MONTAGGIO.

The noted version is C1-C2.
 To see further alternatives please refer to section MOUNTING POSITIONS.

Die dargestellte Version ist C1-C2.
 Für die anderen Versionen siehe MONTAGEPOSITIONEN.

1.8 Lubrificazione

1.8 Lubrication

1.8 Schmierung

Quantità di lubrificante / Lubricant quantity / Schmiermittelmenge [Kg]										
RX 700 Series	Posizione di montaggio Mounting position Einbaulage						Stato di fornitura State of supply Lieferzustand	N° tappi No. of plugs Anzahl Betriebschraubei	Posizione di montaggio Mounting position Montageposition	
	M1	M2	M3	M4	M5	M6				
RXO1	704	0.600						Riduttori forniti completi di lubrificante sintetico Gearboxes supplied with synthetic oil Getriebe werden mit synthetischem Öl geliefert	8	Non necessaria Not necessary Nicht erforderlich
	708	1.00	1.00	1.40	1.20	1.30	1.30	Riduttori predisposti per lubrificazione ad olio* Gearboxes supplied ready for oil lubrication Getriebe sind für Ölschmierung vorgesehen	Necessaria Necessary Erforderlich	
	712	2.20	2.20	2.50	2.50	2.60	2.60			
	716	4.00	4.00	4.40	4.40	4.50	4.50			
720	9.10	9.10	10.2	10.5	13.3	13.3				
RXO2	708	1.10	1.10	1.40	1.40	1.20	1.20	Riduttori predisposti per lubrificazione ad olio* Gearboxes supplied ready for oil lubrication Getriebe sind für Ölschmierung vorgesehen	Necessaria Necessary Erforderlich	
	712	2.20	2.20	2.50	2.50	2.60	2.60			
	716	3.70	3.70	4.50	4.50	4.80	4.80			
	720	8.70	8.70	12.2	12.4	13.3	13.3			

Quantità di lubrificante / Lubricant quantity / Schmiermittelmenge [Kg]										
RX 700 Series	Posizione di montaggio Mounting position Einbaulage						Stato di fornitura State of supply Lieferzustand	N° tappi No. of plugs Anzahl Betriebschraubei	Posizione di montaggio Mounting position Montageposition	
	M1	M2	M3	M4	M5	M6				
RXV1	704	0.600						Riduttori forniti completi di lubrificante sintetico Gearboxes supplied with synthetic oil Getriebe werden mit synthetischem Öl geliefert	8	Non necessaria Not necessary Nicht erforderlich
	708	1.00	1.00	1.40	1.20	1.30	1.30	Riduttori predisposti per lubrificazione ad olio* Gearboxes supplied ready for oil lubrication Getriebe sind für Ölschmierung vorgesehen	Necessaria Necessary Erforderlich	
	712	2.20	2.20	2.50	2.50	2.60	2.60			
	716	4.00	4.00	4.40	4.40	4.50	4.50			
720	9.10	9.10	10.2	10.5	13.3	13.3				
RXV2	708	1.10	1.10	1.40	1.40	1.20	1.20	Riduttori predisposti per lubrificazione ad olio* Gearboxes supplied ready for oil lubrication Getriebe sind für Ölschmierung vorgesehen	Necessaria Necessary Erforderlich	
	712	2.20	2.20	2.50	2.50	2.60	2.60			
	716	3.70	3.70	4.50	4.50	4.80	4.80			
	720	8.70	8.70	12.2	12.4	13.3	13.3			

Le quantità di olio sono approssimative; per una corretta lubrificazione occorre fare riferimento al livello segnato sul riduttore.

Oil quantities listed in the table are approximate; to ensure correct lubrication, please refer to the level mark on the gear unit.

Bei den Ölmengeangaben handelt es sich um approximative Werte; für den Erhalt einer korrekten Schmierung muss Bezug auf den am Getriebe gekennzeichneten Füllstand genommen werden.

*Su richiesta possono essere forniti completi di lubrificante sintetico del tipo OMA LA S4 WE 320.

*On request they can be supplied oil filled with synthetic lubricant OMA LA S4 WE 320.

*Auf Anfrage können Sie mit synthetischem Öl Typ OMA LA S4 WE 320 geliefert werden.

ATTENZIONE

Il tappo di sfiato è allegato solo nei riduttori che hanno più di un tappo olio.

WARNING

A breather plug is supplied only with gearboxes that have more than one oil plug.

ACHTUNG

Der Entlüftungsstopfen ist lediglich bei den Getrieben vorhanden, die über mehr als einen Ölfüllstopfen verfügen.

Eventuali forniture con predisposizioni tappi diverse da quella indicata in tabella, dovranno essere concordate.

The supply of gearboxes with different plug pre-arrangements has to be agreed with the manufacturer.

Lieferungen, die eine Auslegung hinsichtlich der Stopfen aufweisen, die von den Angaben in der Tabelle abweichen, müssen vorab vereinbart werden.

Nei riduttori dove è necessario specificare la posizione di montaggio, la posizione richiesta è indicata nella targhetta del riduttore.

The gearboxes that need a specific assembling position have the indication of it on the label of the gearbox.

In den Getrieben in dem man die Montage Position angeben soll, findet man die angefragte Position auf dem Typenschild des Getriebes.

1.8 Lubrificazione

1.8 Lubrication

1.8 Schmierung

Posizioni di montaggio

Mounting positions

Einbaulagen

RX 800 - Series

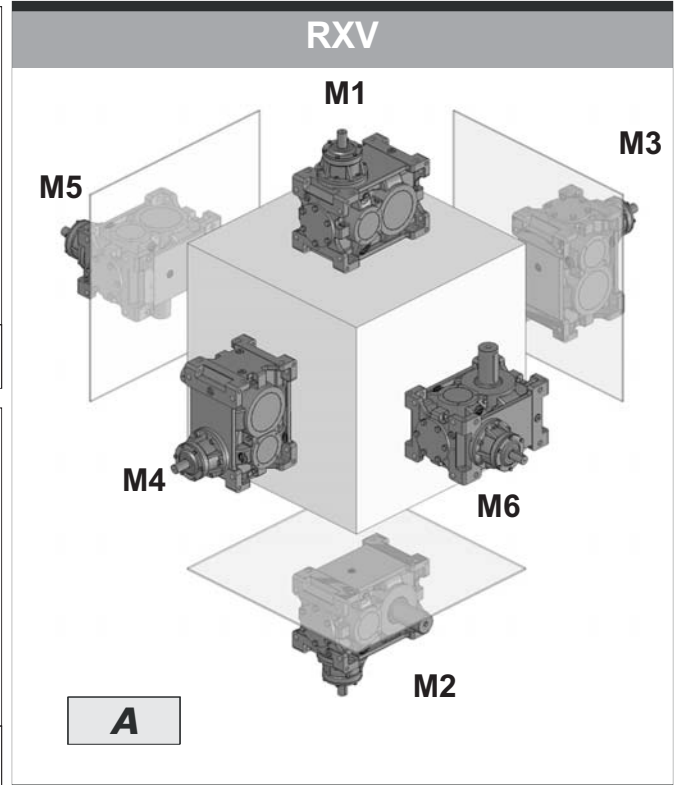
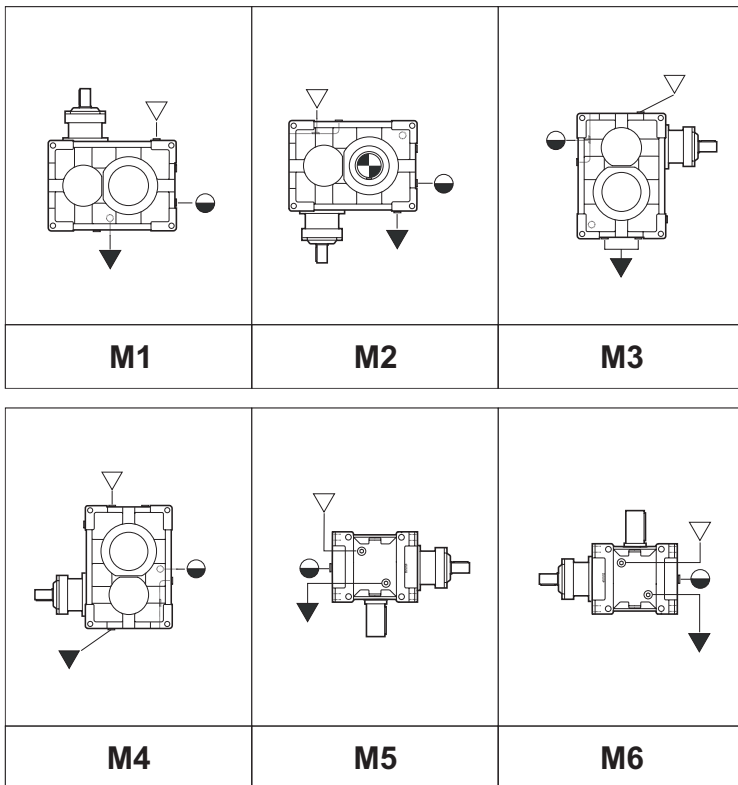
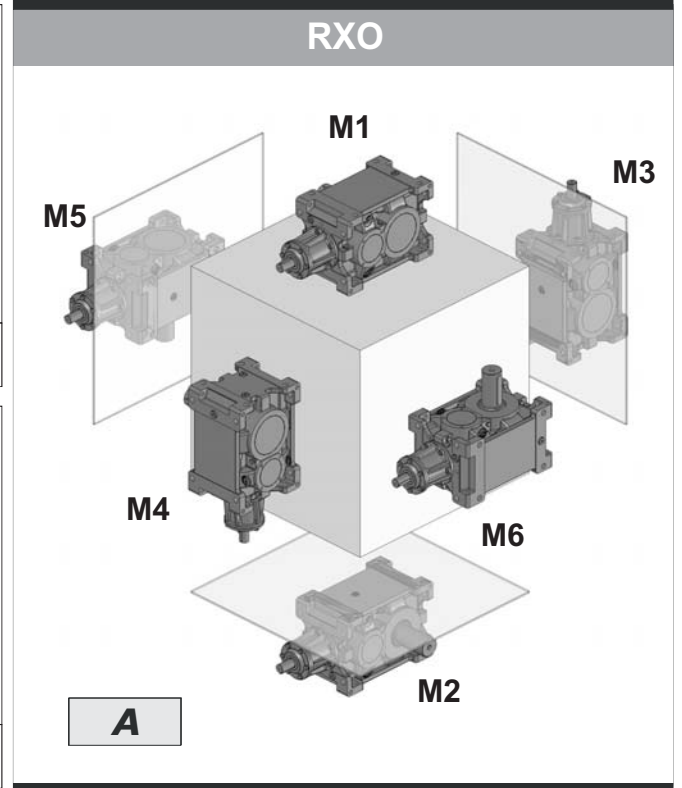
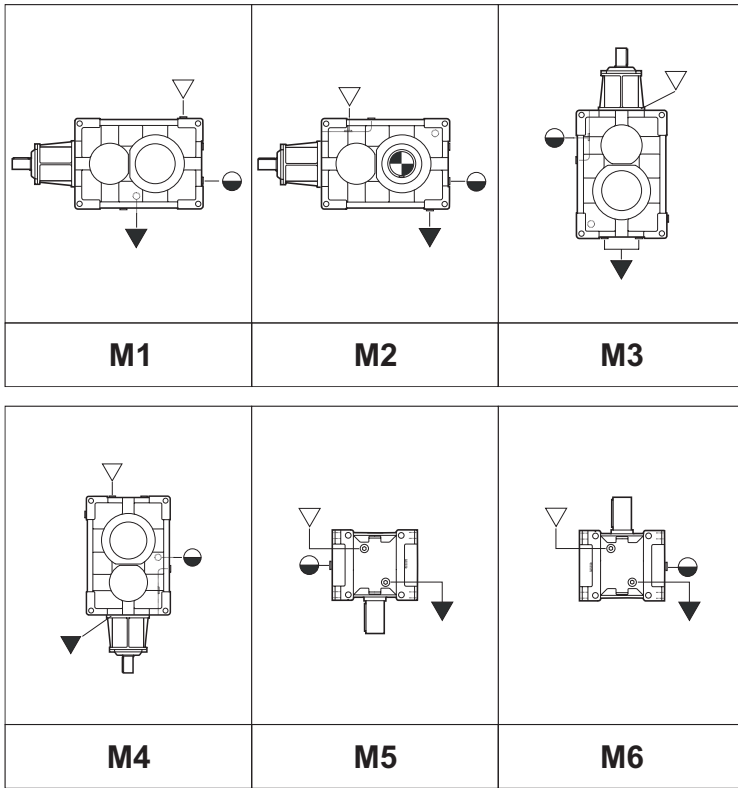

N.B. schema rappresentativo anche per 2-3-4 stadi
 NOTE Diagram applies to 2-3-4 reduction units as well
 HINWEIS: Schema auch für 2-3-4 Stufen gültig

- ▽ Carico / Filler plug / Einfüllschraube
- ▼ Scarico / Drain plug / Ablassschraube
- Livello / Level plug / Schauglas

L'esecuzione grafica rappresentata è la A.
 Per le altre esecuzioni grafiche vedere sezione POSIZIONI MONTAGGIO.
 The noted version is A.
 To see further alternatives please refer to section MOUNTING POSITIONS.
 Die dargestellte Version ist A.
 Für die anderen Versionen siehe MONTAGEPOSITIONEN.

1.8 Lubrificazione

1.8 Lubrication

1.8 Schmierung

RX 800 Series		Quantità di lubrificante / Lubricant Quantity / Schmiermittelmenge (l)															
		802	804	806	808	810	812	814	816	818	820	822	824	826	828	830	832
RXO1 RXV1	M1 - M2	2,5	3,5	4,9	6,9	9,6	13,0	19,0	26,0	37,0	52,0	72,0	100,0	—	—	—	—
	M3	3,8	5,3	7,5	11,0	15,0	21,0	30,0	42,0	61,0	85,0	115,0	156,0	—	—	—	—
	M4	3,5	4,9	7,0	9,8	14,0	22,0	28,0	40,0	56,0	78,0	111,0	152,0	—	—	—	—
	M5 - M6	3,6	5,0	7,1	10,0	14,0	20,0	29,0	40,0	57,0	79,0	110,0	151,0	—	—	—	—
RXO2 RXV2	M1 - M2	3,3	4,7	6,5	9,0	13,0	18,0	25,0	35,0	49,0	69,0	113,0	158,0	221,0	265,0	370,0	—
	M3	6,1	8,6	12,0	17,0	24,0	34,0	48,0	68,0	95,0	133,0	201,0	285,0	400,0	a richiesta		—
	M4	5,1	7,2	10,0	15,0	20,0	29,0	40,0	56,0	80,0	114,0	156,0	218,0	306,0			—
	M5 - M6	4,6	6,5	9,4	13,0	18,0	25,0	35,0	50,0	70,0	99,0	139,0	196,0	275,0	—	—	—
RXO3 RXV3	M1 - M2	3,9	5,5	7,6	11,0	15,0	21,0	29,0	41,0	58,0	81,0	113,0	158,0	221,0	310,0	433,0	605,0
	M3	8,1	11,0	15,0	22,0	32,0	44,0	62,0	87,0	125,0	175,0	246,0	345,0	485,0	a richiesta		—
	M4	6,6	9,2	13,0	18,0	26,0	36,0	50,0	71,0	102,0	144,0	201,0	285,0	400,0			—
	M5 - M6	5,1	7,3	10,0	14,0	20,0	28,0	40,0	56,0	79,0	111,0	156,0	218,0	306,0	—	—	—
RXO4	M1 - M2	4,9	6,4	9,5	12,8	18,8	24,4	36,3	47,6	58,0	81,0	113,0	158,0	221,0	310,0	433,0	605,0
	M3	10,1	12,8	18,8	25,5	40,0	51,0	77,5	100,9	125,0	175,0	246,0	345,0	485,0	a richiesta		—
	M4	8,3	10,7	16,3	20,9	32,5	41,8	62,5	82,4	102,0	144,0	201,0	285,0	400,0			—
	M5 - M6	7,1	9,5	14,0	18,2	28,0	36,4	56,0	72,8	79,0	111,0	156,0	218,0	306,0	—	—	—

Le quantità di olio sono approssimative; per una corretta lubrificazione occorre fare riferimento al livello segnato sul riduttore.

ATTENZIONE

Eventuali forniture con predisposizioni tappi diverse da quella indicata in tabella, dovranno essere concordate.

Oil quantities listed in the table are approximate; to ensure correct lubrication, please refer to the level mark on the gear unit.

WARNING

Any plug arrangements other than that indicated in the table must be agreed upon.

Bei den Ölmengeangaben handelt es sich um approximative Werte; für den Erhalt einer korrekten Schmierung muss Bezug auf den am Getriebe gekennzeichneten Füllstand genommen werden.

ACHTUNG

Eventuelle Lieferungen mit einer von den Tabellenangaben abweichenden Anordnung der Stopfen müssen zuvor abgestimmt werden.

Lubrificazione cuscinetti superiori

Upper bearing lubrication

Schmierung der obenliegenden Lager

La lubrificazione forzata dei cuscinetti superiori viene associata alla lubrificazione forzata degli ingranaggi nel caso quest'ultima sia necessaria.

Forced lubrication for upper bearings is normally associated with forced lubrication for the gears, where necessary.

Die Zwangsschmierung der obenliegenden Lager wird mit der Zwangsschmierung der Zahnräder, für die sind, assoziiert.

Pos. Mont. / Mntg. Pos. / Einbaulage M1- M5 - M6

RXO RXV	M5 M6	n ₁ [min ⁻¹]	Grandezza / Size / Baugröße												
			802-810	812	814	816	818	820	822	824	826	828	830	832	
RXO3 RXV3		0 - n _{1max}	G									LFM3		LFM4	
RXO2 RXV2		1751 - n _{1max}	G			LFM2			LFM2			LFM3		LFM4	
		1000 - 1750	G						LFM2			LFM3		LFM4	
RXO1 RXV1		0 - 999	G						LFM2			LFM2		LFM3	
		1751 - n _{1max}	G			LFM2			LFM2			LFM3			
		1000 - 1750	G						LFM2			LFM2		LFM3	
		0 - 999	G												

Pos. Mont. / Mntg. Pos. / Einbaulage M3 - M4

	n ₁ [min ⁻¹]	Grandezza / Size / Baugröße												
		802-808	810	812	814	816	818	820	822	824	826	828	830	832
RXO1 RXV1	1751 - n _{1max}	G			LFM1			LFM2						
	1000 - 1750	G			LFM1			LFM2						
	0 - 999	G			LFM1			LFM2						
RXO2 RXV2	1751 - n _{1max}	G			LFM1			LFM1			LFM2			
	1000 - 1750	G			LFM1			LFM1			LFM2			
	0 - 999	G			LFM1			LFM1			LFM2		LFM3	
RXO3 RXV3	0 - n _{1max}	G			LFM1			LFM2			LFM2		LFM3	

I valori di n_{1max} sono riportati nel paragrafo Verifiche, punto 4.

n_{1max} values are listed at paragraph Verification, point 4.

Die Werte von n_{1max} werden im Paragraph "Kontrollen", Punkt 4, angegeben.

	l/min	Motor	P (kW)	A
LFM1	0.5	71A4	0.25	172
LFM2	5			
LFM2	10	80A4	0.55	197
LFM4	20	80B4	0.75	
LFM5	30	90S4	1.1	214

LFM.: Motopompa (vedi sezione U accessori e opzioni).



LFM.: Motor pump (see Section Accessories and Options U).

LFM.: Motorpumpe (siehe Abschnitt "Zubehör und Optionen U).

1.9 Prestazioni riduttori RXO-RXV

1.9 RXO-RXV gear unit ratings

1.9 Leistungen der RXO-V Getriebe

RX 700  ECE-12.5 PAM-15.5							704						RX 708  ECE-20 PAM-25					
n_{1-1} min ⁻¹	ir	n_2 min ⁻¹	P_N kW	T_N Nm	Fr_1 N	Fr_2 N	ir	n_2 min ⁻¹	P_N kW	T_N Nm	Fr_1 N	Fr_2 N						
2850																		
1450							5.2	553.3	17.3	283.9	500	5000						
1000								281.5	9.6	310.0	1000	6000						
500								194.1	6.7	314.7	1000	6700						
2850								97.1	3.4	314.7	1000	8000						
1450							7.1	400.7	15.4	348.0	500	5000						
1000								203.9	8.5	380.0	1000	6000						
500								140.6	6.0	385.7	1000	6700						
2850								70.3	3.0	385.7	1000	8000						
1450								286.0	12.7	402.9	500	5000						
1000								145.5	7.1	440.0	1000	6000						
500								100.3	4.9	446.6	1000	6700						
2850								50.2	2.5	446.6	1000	8000						
1450								238.6	11.1	421.3	500	5000						
1000								121.4	6.2	460.0	1000	6000						
500								83.7	4.3	466.9	1000	6700						
2850	9.5	299.8	7.0	210.6	300	3000		41.9	2.2	466.9	1000	8000						
1450		152.5	3.9	230.0	630	3350		194.7	9.4	439.6	500	5000						
1000		105.2	2.7	233.5	630	4000		99.1	5.2	480.0	1000	6300						
500		52.6	1.4	233.5	630	4750		68.3	3.7	487.2	1000	7100						
2850		206.3	4.8	210.6	300	3150		34.2	1.8	487.2	1000	8000						
1450		105.0	2.7	230.0	630	3750		170.9	8.6	457.9	500	5000						
1000		72.4	1.9	233.5	630	4250		87.0	4.8	500.0	1000	6700						
500		36.2	0.9	233.5	630	5000		60.0	3.4	507.5	1000	7100						
2850		187.3	4.7	228.9	300	3350		30.0	1.7	507.5	1000	8000						
1450		95.3	2.6	250.0	630	4000		134.4	6.8	457.9	500	6000						
1000		65.7	1.8	253.8	630	4500		68.4	3.8	500.0	1000	7100						
500		32.9	0.9	253.8	630	5000		47.1	2.6	507.5	1000	7500						
2850		154.0	3.7	219.8	300	3550		23.6	1.3	507.5	1000	8000						
1450		78.4	2.1	240.0	630	4250		117.9	6.1	467.1	400	6000						
1000		54.0	1.5	243.6	630	4750		60.0	3.4	510.0	800	7100						
500		27.0	0.7	243.6	630	5000		41.4	2.4	517.7	800	8000						
2850		128.9	3.4	238.1	250	3750		20.7	1.2	517.7	800	8000						
1450		65.6	1.9	260.0	500	4500		91.9	4.8	476.2	400	6300						
1000		45.2	1.3	263.9	500	5000		46.7	2.7	520.0	800	7500						
500		22.6	0.7	263.9	500	5000		32.2	1.9	527.8	800	8000						
2850		106.0	2.7	228.9	250	4000		16.1	0.9	527.8	800	8000						
1450		53.9	1.5	250.0	500	4750		71.7	3.8	476.2	400	6700						
1000		37.2	1.0	253.8	500	5000		36.5	2.1	520.0	800	8000						
500		18.6	0.5	253.8	500	5000		25.1	1.5	527.8	800	8000						
2850		78.3	2.0	228.9	250	4250		12.6	0.7	527.8	800	8000						
1450		39.8	1.1	250.0	500	5000		55.8	3.0	494.5	300	7100						
1000		27.5	0.8	253.8	500	5000		28.4	1.7	540.0	630	8000						
500		13.7	0.4	253.8	500	5000		19.6	1.2	548.1	630	8000						
2850		64.4	1.7	238.1	200	4500		9.8	0.6	548.1	630	8000						
1450		32.8	0.9	260.0	400	5000		50.0	2.5	457.9	300	7100						
1000		22.6	0.7	263.9	400	5000		25.4	1.4	500.0	630	8000						
500		11.3	0.3	263.9	400	5000		17.5	1.0	507.5	630	8000						
2850		54.6	1.4	228.9	200	4500		8.8	0.5	507.5	630	8000						
1450		27.8	0.8	250.0	400	5000		38.9	2.0	457.9	300	7100						
1000		19.2	0.5	253.8	400	5000		19.8	1.1	500.0	630	8000						
500		9.6	0.3	253.8	400	5000		13.7	0.8	507.5	630	8000						
2850		44.9	1.1	228.9	200	4500		6.8	0.4	507.5	630	8000						
1450		22.8	0.6	250.0	400	5000												
1000		15.8	0.4	253.8	400	5000												
500		7.9	0.2	253.8	400	5000												
Potenze termiche / Thermal power / Termische Grenzleistung P_{tN} [kW]																		
(senza raffreddamento / Without cooling / ohne Kühlung)																		
7.5							11											



ECE-34 PAM-40 712							ECE-58 PAM-70 716					
n_{1-1} min ⁻¹	ir	n_2 min ⁻¹	P_N kW	T_N Nm	Fr_1 N	Fr_2 N	ir	n_2 min ⁻¹	P_N kW	T_N Nm	Fr_1 N	Fr_2 N
2850	5.2	553.3	27.9	457.9	800	8000	5.2	553.3	55.8	915.8	1250	12500
1450		281.5	15.5	500.0	1600	10000		281.5	31.0	1000.0	2500	16000
1000		194.1	10.9	507.5	1600	10600		194.1	21.7	1015.0	2500	17000
500	7.4	97.1	5.4	507.5	1600	11800	500	97.1	10.9	1015.0	2500	20000
2850		384.4	29.5	696.0	800	8000	2850	384.4	50.4	1190.5	1250	12500
1450		195.6	16.4	760.0	1600	10000	1450	195.6	28.0	1300.0	2500	16000
1000	134.9	11.5	771.4	1600	10600	1000	134.9	19.6	1319.5	2500	17000	
500	10.0	67.4	5.7	771.4	1600	11800	500	67.4	9.8	1319.5	2500	20000
2850		286.0	28.3	897.5	800	8000	2850	286.0	51.0	1648.4	1250	12500
1450		145.5	15.7	980.0	1600	10000	1450	142.7	28.3	1800.0	2500	16000
1000	100.3	11.0	994.7	1600	10600	1000	98.4	19.8	1827.0	2500	17000	
500	12.2	50.2	5.5	994.7	1600	11800	500	49.2	9.9	1827.0	2500	20000
2850		234.3	23.7	915.8	800	8000	2850	234.3	44.9	1740.0	1250	12500
1450		119.2	13.1	1000.0	1600	10000	1450	119.2	25.0	1900.0	2500	16000
1000	82.2	9.2	1015.0	1600	10600	1000	82.2	17.5	1928.5	2500	17000	
500	14.6	41.1	4.6	1015.0	1600	11800	500	41.1	8.7	1928.5	2500	20000
2850		194.7	19.7	915.8	800	8000	2850	194.7	39.3	1831.6	1250	12500
1450		99.1	10.9	1000.0	1600	10000	1450	99.1	21.8	2000.0	2500	16000
1000	68.3	7.6	1015.0	1600	11200	1000	68.3	15.3	2030.0	2500	18000	
500	17.0	34.2	3.8	1015.0	1600	12500	500	34.2	7.6	2030.0	2500	20000
2850		168.0	18.7	1007.4	800	8000	2850	168.0	33.9	1831.6	1250	14000
1450		85.5	10.4	1100.0	1600	10000	1450	85.5	18.8	2000.0	2500	16000
1000	59.0	7.3	1116.5	1600	11200	1000	59.0	13.2	2030.0	2500	19000	
500	21.2	29.5	3.6	1116.5	1600	12500	500	29.5	6.6	2030.0	2500	20000
2850		134.4	14.9	1007.4	800	8500	2850	134.4	28.5	1923.2	1250	15000
1450		68.4	8.3	1100.0	1600	10600	1450	68.4	15.8	2100.0	2500	17000
1000	47.1	5.8	1116.5	1600	11800	1000	47.1	11.1	2131.5	2500	20000	
500	24.6	23.6	2.9	1116.5	1600	12500	500	23.6	5.5	2131.5	2500	20000
2850		115.9	11.7	915.8	650	10000	2850	115.9	24.6	1923.2	1000	15000
1450		59.0	6.5	1000.0	1250	11200	1450	59.0	13.7	2100.0	2000	18000
1000	40.7	4.6	1015.0	1250	12500	1000	40.7	9.6	2131.5	2000	20000	
500	31.0	20.3	2.3	1015.0	1250	12500	500	20.3	4.8	2131.5	2000	20000
2850		91.9	9.3	915.8	650	10000	2850	89.2	18.0	1831.6	1000	16000
1450		46.7	5.2	1000.0	1250	11800	1450	45.4	10.0	2000.0	2000	19000
1000	32.2	3.6	1015.0	1250	12500	1000	31.3	7.0	2030.0	2000	20000	
500	40.5	16.1	1.8	1015.0	1250	12500	500	15.7	3.5	2030.0	2000	20000
2850		70.4	7.1	915.8	650	10600	2850	70.4	14.2	1831.6	1000	17000
1450		35.8	4.0	1000.0	1250	12500	1450	35.8	7.9	2000.0	2000	20000
1000	24.7	2.8	1015.0	1250	12500	1000	24.7	5.5	2030.0	2000	20000	
500	51.0	12.4	1.4	1015.0	1250	12500	500	12.4	2.8	2030.0	2000	20000
2850		55.8	5.6	915.8	500	11200	2850	54.2	10.9	1831.6	800	18000
1450		28.4	3.1	1000.0	1000	12500	1450	27.6	6.1	2000.0	1600	20000
1000	19.6	2.2	1015.0	1000	12500	1000	19.0	4.3	2030.0	1600	20000	
500	58.0	9.8	1.1	1015.0	1000	12500	500	9.5	2.1	2030.0	1600	20000
2850		49.1	5.0	915.8	500	11200	2850	49.1	9.9	1831.6	800	18000
1450		25.0	2.8	1000.0	1000	12500	1450	25.0	5.5	2000.0	1600	20000
1000	17.2	1.9	1015.0	1000	12500	1000	17.2	3.9	2030.0	1600	20000	
500	73.2	8.6	1.0	1015.0	1000	12500	500	8.6	1.9	2030.0	1600	20000
2850		38.9	3.9	915.8	500	12500	2850	37.8	7.6	1831.6	800	18000
1450		19.8	2.2	1000.0	1000	12500	1450	19.2	4.2	2000.0	1600	20000
1000	13.7	1.5	1015.0	1000	12500	1000	13.3	3.0	2030.0	1600	20000	
500		6.8	0.8	1015.0	1000	12500	500	6.6	1.5	2030.0	1600	20000
Potenze termiche / Thermal power / Termische Grenzleistung P_{IN} [kW] (senza raffreddamento / Without cooling / ohne Kühlung)												
16.5							25					

1.9 Prestazioni riduttori RXO-RXV

1.9 RXO-RXV gear unit ratings

1.9 Leistungen der RXO-V Getriebe

RX 700		 ECE-123 PAM-140	720			
n_{1-1} min ⁻¹	ir	n_2 min ⁻¹	P_N kW	T_N Nm	Fr_1 N	Fr_2 N
2850	7.6	375.6	151.6	3663.2	2000	12000
1450		191.1	84.2	4000.0	4000	18000
1000		131.8	59.0	4060.0	4000	22000
500		65.9	29.5	4060.0	4000	28000
2850	10.3	277.1	111.9	3663.2	2000	14000
1450		141.0	62.2	4000.0	4000	20000
1000		97.2	43.5	4060.0	4000	24000
500		48.6	21.8	4060.0	4000	30000
2850	12.3	232.5	96.2	3754.7	2000	16000
1450		118.3	53.5	4100.0	4000	22000
1000		81.6	37.4	4161.5	4000	26000
500		40.8	18.7	4161.5	4000	32000
2850	14.9	190.7	80.8	3846.3	2000	18000
1450		97.0	44.9	4200.0	4000	24000
1000		66.9	31.4	4263.0	4000	28000
500		33.5	15.7	4263.0	4000	34000
2850	20.2	141.1	59.8	3846.3	2000	20000
1450		71.8	33.2	4200.0	4000	26000
1000		49.5	23.3	4263.0	4000	30000
500		24.8	11.6	4263.0	4000	35000
2850	24.6	115.8	50.2	3937.9	2000	22000
1450		58.9	27.9	4300.0	4000	28000
1000		40.6	19.5	4364.5	4000	32000
500		20.3	9.8	4364.5	4000	35000
2850	33.4	85.4	37.9	4029.5	2000	24000
1450		43.4	21.1	4400.0	4000	30000
1000		30.0	14.7	4466.0	4000	34000
500		15.0	7.4	4466.0	4000	35000
2850	40.7	70.0	29.0	3754.7	2000	26000
1450		35.6	16.1	4100.0	4000	32000
1000		24.6	11.3	4161.5	4000	35000
500		12.3	5.6	4161.5	4000	35000
2850	51.3	55.6	25.2	4121.1	2000	28000
1450		28.3	14.0	4500.0	4000	34000
1000		19.5	9.8	4567.5	4000	35000
500		9.7	4.9	4567.5	4000	35000
2850	57.4	49.6	21.0	3846.3	2000	30000
1450		25.3	11.7	4200.0	4000	35000
1000		17.4	8.2	4263.0	4000	35000
500		8.7	4.1	4263.0	4000	35000
2850	72.3	39.4	15.9	3663.2	2000	32000
1450		20.1	8.8	4000.0	4000	35000
1000		13.8	6.2	4060.0	4000	35000
500		6.9	3.1	4060.0	4000	35000
Potenze termiche / Thermal power / Termische Grenzleistung P_{TN} [kW] (senza raffreddamento / Without cooling / ohne Kühlung)						
39.0						



1.9 Prestazioni riduttori RXO-RXV

1.9 RXO-RXV gear unit ratings

1.9 Leistungen der RXO-V Getriebe

RX 800 82 802						114 804					154 806				
n_1 min ⁻¹	ir	n_2 min ⁻¹	P_N kW	T_N kNm	$\frac{Fr_2}{Fr_1}$ kN	ir	n_2 min ⁻¹	P_N kW	T_N kNm	$\frac{Fr_2}{Fr_1}$ kN	ir	n_2 min ⁻¹	P_N kW	T_N kNm	$\frac{Fr_2}{Fr_1}$ kN
1450	4.40	329	40	1.1	10.2 2.9	4.39	331	58	1.6	13.6 3.6	4.93				16.3 4.6
1000		227	33	1.3			228	45	1.8						
500		114	18.8	1.5			114	26	2.1						
1450	5.22	278	40	1.3	9.7 3.0	4.93	294	58	1.8	13.0 3.8	4.93	294	84	2.6	16.3 4.6
1000		192	32	1.5			203	47	2.1			203	65	2.9	
500		96	19.0	1.8			101	27	2.4			101	37	3.3	
1450	5.54	262	40	1.4	9.1 3.2	5.57	260	60	2.1	12.2 4.0	5.57	260	83	2.9	15.3 4.9
1000		181	32	1.6			180	45	2.3			180	63	3.2	
500		90	18.9	1.9			90	27	2.7			90	37	3.7	
1450	6.26	232	41	1.6	8.3 3.3	5.93	244	59	2.2	11.5 4.2	5.93	244	83	3.1	14.7 5.1
1000		160	32	1.8			169	46	2.5			169	63	3.4	
500		80	17.6	2.0			84.3	26	2.8			84	36	3.9	
1450	7.13	203	40	1.8	9.6 3.5	6.77	214	59	2.5	12.9 4.4	6.77	214	83	3.5	16.2 5.4
1000		140	31	2.0			148	46	2.8			148	63	3.9	
500		70	16.2	2.1			73.9	24	3.0			73.9	37	4.5	
1450	7.63	190	42	2.0	7.4 3.6	7.25	200	59	2.7	10.0 4.6	7.25	200	81	3.7	12.5 5.6
1000		131	30	2.1			138	46	3.0			138	64	4.2	
500		66	15.1	2.1			69.0	24	3.1			69	35	4.6	
1450	8.81	165	40	2.2	7.0 3.8	8.39	173	59	3.1	8.3 4.8	8.39	173	82	4.3	9.5 5.9
1000		113	27	2.2			119	42	3.2			119	62	4.7	
500		57	13.7	2.2			60	21	3.2			60	32	4.8	
1450	9.52	152	37	2.2	9.3 3.9	9.83	148	50	3.1	10.4 5.0	9.83	148	75	4.6	11.6 6.1
1000		105	25	2.2			102	36	3.2			102	53	4.7	
500		53	12.7	2.2			51	18.5	3.3			51	27	4.8	
1450	11.2	129	30	2.1	10.3 4.1	10.7	135	43	2.9	11.9 5.2	10.7	135	64	4.3	13.5 6.4
1000		89	21	2.1			93	31	3.0			93	45	4.4	
500		45	10.8	2.2			47	15.9	3.1			47	23	4.5	
1450	13.3	109	24	2.0	11.1 4.2	12.6	115	33	2.6	15.0 5.4	12.6	115	48	3.8	18.8 7.1
1000		75.4	17.4	2.1			79	23	2.6			79	34	3.9	
500		37.7	9.1	2.2			40	11.8	2.7			40	17.4	4.0	
1450	14.3	101	25	2.2	12.1 4.4	14.8	98	32	3.0	16.4 5.6	14.8	98	48	4.4	20.6 7.6
1000		69.8	16.9	2.2			68	23	3.1			68	34	4.5	
500		34.9	8.5	2.2			34	11.9	3.2			34	17.5	4.7	
1450	16.9	86	19.9	2.1	10.9 4.5	16.1	90	30	3.0	14.9 6.2	16.1	90	44	4.4	18.8 7.1
1000		59	13.7	2.1			62	21	3.0			62	31	4.5	
500		30	7.2	2.2			31	10.9	3.2			31	15.7	4.6	
1450	18.5	79	16.4	1.9	10.4 4.7	17.6	82	25	2.8	14.3 5.8	17.6	82	36	4.0	18.1 7.4
1000		54	11.9	2.0			57	17.5	2.8			57	26	4.1	
500		27	6.0	2.0			28	9.1	2.9			28	13.4	4.3	
1450	20.1	72	11.9	1.5	12.1 4.8	20.7	70	16.9	2.2	16.4 6.0	20.7	70	23	3.0	20.6 7.6
1000		50	8.2	1.5			48	11.7	2.2			48	16.5	3.1	
500		25	4.4	1.6			24	6.1	2.3			24	8.5	3.2	
1450	23.7	61	12.1	1.8	13.6 5.0	22.6	64	17.0	2.4	18.2 6.2	22.6	64	23	3.3	22.7 7.9
1000		42	8.4	1.8			44	11.7	2.4			44	16.1	3.3	
500		21	4.4	1.9			22	6.1	2.5			22	8.5	3.5	
1450	25.9	56	11.7	1.9	13.1 5.1	24.7	59	16.8	2.6	17.8 6.4	24.7	59	23	3.6	22.5 8.1
1000		39	8.5	2.0			40	12.0	2.7			40	16.5	3.7	
500		19.3	4.3	2.0			20	6.2	2.8			20	8.5	3.8	

Potenze termiche - Thermal power - Thermische Grenzleistung
(senza raffreddamento / Without cooling / ohne Kühlung)

30



39

51

1.9 Prestazioni riduttori RXO-RXV

1.9 RXO-RXV gear unit ratings

1.9 Leistungen der RXO-V Getriebe

RX 800  211 808						 292 810					 387 812				
n_1 min ⁻¹	ir	n_2 min ⁻¹	P_N kW	T_N kNm	$\frac{Fr_2}{Fr_1}$ kN	ir	n_2 min ⁻¹	P_N kW	T_N kNm	$\frac{Fr_2}{Fr_1}$ kN	ir	n_2 min ⁻¹	P_N kW	T_N kNm	$\frac{Fr_2}{Fr_1}$ kN
1450	4.39	331	116	3.2	22.9 6.6	4.39	331	149	4.1	28.6 7.9	4.48	324	196	5.5	35.0 10.2
1000		228	88	3.5			228	105	4.2			223	153	6.2	
500		114	44	3.5			114	53	4.2			112	76	6.2	
1450	4.93	294	113	3.5	22.1 6.8	4.93	294	149	4.6	27.6 8.3	5.03	288	197	6.2	33.7 10.5
1000		203	89	4.0			203	105	4.7			199	153	7.0	
500		101	45	4.0			101	52	4.7			99	77	7.0	
1450	5.57	260	115	4.0	20.9 7.1	5.57	260	149	5.2	26.3 8.6	5.67	256	197	7.0	32.1 10.9
1000		180	88	4.5			180	105	5.3			176	153	7.9	
500		90	44	4.5			90	52	5.3			88	77	7.9	
1450	6.33	229	116	4.6	20.3 7.3	6.33	229	149	5.9	25.4 8.9	6.44	225	198	8.0	30.0 11.2
1000		158	89	5.1			158	104	6.0			155	152	8.9	
500		79	44	5.1			79	52	6.0			78	77	9.0	
1450	7.25	200	115	5.2	22.9 7.6	7.25	200	148	6.7	28.7 9.2	6.89	211	197	8.5	33.3 11.6
1000		138	88	5.8			138	105	6.9			145	152	9.5	
500		69	44	5.8			69	52	6.9			73	77	9.6	
1450	7.79	186	115	5.6	18.9 7.8	7.79	186	148	7.2	23.9 9.6	7.92	183	198	9.8	26.4 11.9
1000		128	89	6.3			128	105	7.4			126	153	11.0	
500		64	45	6.3			64	52	7.4			63	76	11.0	
1450	9.06	160	115	6.5	15.8 8.1	8.39	173	148	7.8	20.1 9.9	8.53	170	198	10.6	23.0 12.3
1000		110	81	6.7			119	105	8.0			117	152	11.8	
500		55	41	6.7			60	53	8.0			59	77	11.9	
1450	9.83	148	106	6.5	17.5 8.3	9.83	148	146	9.0	22.6 10.2	9.99	145	199	12.4	27.3 12.6
1000		102	75	6.7			102	103	9.2			100	144	13.1	
500		51	38	6.8			51	52	9.3			50	73	13.3	
1450	10.7	135	91	6.1	19.5 8.6	10.7	135	125	8.4	25.3 10.5	10.9	133	176	12.0	28.1 13.0
1000		93	64	6.2			93	87	8.5			92	124	12.2	
500		47	33	6.4			47	45	8.8			46	64	12.7	
1450	11.7	124	68	5.0	27.6 8.8	11.7	124	105	7.7	34.4 10.9	11.9	122	149	11.1	40.8 13.3
1000		85	48	5.1			85	74	7.9			84	105	11.3	
500		43	25	5.3			43	39	8.2			42	54	11.7	
1450	14.8	98	68	6.3	29.3 9.1	14.8	98	93	8.6	36.4 11.2	15.0	96	133	12.5	41.9 13.7
1000		68	48	6.4			68	66	8.8			67	93	12.7	
500		34	25	6.7			34	34	9.1			33	48	13.2	
1450	16.1	90	61	6.2	25.7 9.3	16.1	90	84	8.5	33.6 11.5	16.4	89	120	12.3	40.8 14.0
1000		62	43	6.3			62	59	8.7			61	84	12.5	
500		31	23	6.6			31	31	9.0			31	43	12.9	
1450	17.6	82	53	5.8	27.0 9.6	17.6	82	72	7.9	32.7 11.8	17.9	81	101	11.3	39.6 14.4
1000		57	37	5.9			57	50	8.0			56	71	11.5	
500		28	19.1	6.1			28	26	8.3			28	37	11.9	
1450	20.7	70	33	4.3	29.3 9.8	20.7	70	45	5.9	36.4 12.2	21.1	69	65	8.6	41.9 14.7
1000		48	23	4.4			48	32	6.1			47	45	8.7	
500		24	11.9	4.5			24	16.7	6.3			24	24	9.0	
1450	22.6	64	33	4.7	31.6 10.1	22.6	64	46	6.5	39.1 12.5	23.0	63	65	9.3	47.4 15.1
1000		44	23	4.8			44	32	6.6			44	46	9.5	
500		22	12.2	5.0			22	16.6	6.8			22	24	9.8	
1450	24.7	59	33	5.1	30.9 10.3	24.7	59	46	7.1	38.8 12.8	25.1	58	65	10.2	45.6 15.4
1000		40	23	5.2			40	32	7.2			40	46	10.4	
500		20	12.0	5.4			20	16.7	7.5			20	23	10.7	
1450	27.2	53	32	5.4	29.3 10.6	27.2	53	43	7.4	36.4 13.1					
1000		37	22	5.5			37	30	7.5						
500		18	11.5	5.7			18	15.8	7.8						

Potenze termiche - Thermal power - Thermische Grenzleistung
(senza raffreddamento / Without cooling / ohne Kühlung)

66

82

104

1.9 Prestazioni riduttori RXO-RXV

1.9 RXO-RXV gear unit ratings



1.9 Leistungen der RXO-V Getriebe

RX 800 561						782						1090					
814						816						818					
n_1 min ⁻¹	ir	n_2 min ⁻¹	P _N kW	T _N kNm	$\frac{Fr_2}{Fr_1}$ kN	ir	n_2 min ⁻¹	P _N kW	T _N kNm	$\frac{Fr_2}{Fr_1}$ kN	ir	n_2 min ⁻¹	P _N kW	T _N kNm	$\frac{Fr_2}{Fr_1}$ kN		
1450	4.40	329	265	7.3	42.3 10.3	4.39	331	379	10.4	55.5 11.0	4.39	331	547	15.0	68.5 19.0		
1000		227	205	8.2			228	284	11.3			228	415	16.5			
500		114	109	8.7			114	142	11.3			114	239	19.0			
1450	4.93	294	266	8.2	41.0 11.0	4.93	294	376	11.6	53.9 11.7	4.93	294	502	15.5	68.1 19.7		
1000		203	206	9.2			203	286	12.8			203	386	17.3			
500		101	110	9.8			101	143	12.8			101	224	20.1			
1450	5.54	262	265	9.2	39.2 11.6	5.57	260	376	13.1	51.6 12.5	5.57	260	502	17.5	65.4 20.5		
1000		181	205	10.3			180	285	14.4			180	386	19.5			
500		90	109	11.0			90	142	14.4			89.8	223	22.6			
1450	6.26	232	265	10.4	36.9 12.2	5.93	244	377	14.0	50.2 13.2	6.33	229	502	19.9	63.6 21.3		
1000		160	204	11.6			169	284	15.3			158	386	22.2			
500		79.9	109	12.4			84	142	15.3			79	224	25.7			
1450	7.13	203	264	11.8	44.1 12.8	6.77	214	377	16.0	58.0 14.0	6.77	214	500	21.2	73.5 22.1		
1000		140	204	13.2			148	284	17.5			148	386	23.7			
500		70	110	14.2			74	142	17.5			74	224	27.5			
1450	7.63	190	266	12.7	38.7 13.5	7.79	186	377	18.4	50.6 14.7	7.25	200	500	22.7	64.2 22.9		
1000		131	205	14.2			128	285	20.1			138	386	25.4			
500		70	110	15.2			64	142	20.1			69	224	29.5			
1450	8.81	165	264	14.6	28.7 14.1	9.06	160	377	21.4	45.3 15.5	8.39	173	501	26.3	57.6 23.7		
1000		113	205	16.4			110	284	23.4			119	386	29.4			
500		57	109	17.5			55	142	23.4			59.6	224	34.1			
1450	9.52	152	265	15.8	32	9.83	148	377	23.2	36.1 16.2	9.83	148	501	30.8	45.4 24.5		
1000		105	205	17.7			102	285	25.4			102	386	34.5			
500		53	109	18.9			51	142	25.4			51	224	40.0			
1450	11.2	129	233	16.4	30.8 15.3	10.7	135	349	23.4	42.4 17.0	10.7	135	501	33.6	53.8 25.3		
1000		89	164	16.7			93	246	23.9			93	359	34.9			
500		45	85	17.3			47	127	24.7			47	186	36.1			
1450	13.3	109	183	15.2	44.4 16.0	11.7	124	294	21.6	62.0 17.7	12.9	113	360	29.1	75.5 26.1		
1000		75	139	16.7			85	208	22.1			78	253	29.6			
500		38	72	17.3			43	107	22.8			39	131	30.6			
1450	14.3	101	183	16.4	49.0 16.6	13.6	106	261	22.3	66.9 18.5	14.8	98	347	32.1	84.3 26.9		
1000		70	138	17.9			73	197	24.4			68	267	35.9			
500		35	69	17.9			37	102	25.3			34	140	37.5			
1450	16.9	86	159	16.8	45.2 17.2	16.1	90	237	23.9	58.2 19.2	16.1	90	346	34.9	73.9 27.7		
1000		59	112	17.1			62	166	24.3			62	243	35.6			
500		30	58	17.7			31	86	25.2			31	126	36.9			
1450	18.5	79	134	15.5	41.8 18.8	17.6	82	200	22.1	60.0 20.0	17.6	82	293	32.3	72.6 28.5		
1000		54	94	15.8			57	141	22.5			57	206	32.9			
500		27	49	16.3			28	73	23.3			28	107	34.1			
1450	20.1	72	96	12.1	49.0 18.5	20.7	70	137	17.8	66.9 20.7	19.4	75	244	29.7	84.3 29.3		
1000		50	68	12.4			48	96	18.1			52	171	30.2			
500		25	35	12.8			24	50	18.8			26	89	31.3			
1450	23.7	61	96	14.3	54.0 19.1	22.6	64	137	19.4	73.0 21.5	22.6	64	187	26.5	90.9 30.1		
1000		42	68	14.6			44	96	19.7			44	132	27.0			
500		21	35	15.1			22	50	20.4			22	68	28.0			
1450	25.9	56	96	15.6	54.3 19.7	24.7	59	137	21.2	71.1 22.2	24.7	59	187	29.0	90.1 30.9		
1000		39	68	15.9			40	96	21.6			40	132	29.6			
500		19.3	35	16.5			20	50	22.4			20	68	30.6			
1450	28.5	51	81	14.4	49.0 20.3	27.2	53	121	20.6	66.9 23.0	27.2	53	177	30.2	84.3 31.7		
1000		35	57	14.7			37	85	21.0			37	124	30.7			
500		17.6	29	15.2			18.4	44	21.7			18.4	64	31.8			
Potenze termiche - Thermal power - Thermische Grenzleistung (senza raffreddamento / Without cooling / ohne Kühlung)																	
127						158						203					

1.9 Prestazioni riduttori RXO-RXV

1.9 RXO-RXV gear unit ratings

1.9 Leistungen der RXO-V Getriebe

RX 800  1522 820						RX 2126  2126 822						RX 2971  2971 824					
n_1 min ⁻¹	ir	n_2 min ⁻¹	P_N kW	T_N kNm	$\frac{Fr_2}{Fr_1}$ kN	ir	n_2 min ⁻¹	P_N kW	T_N kNm	$\frac{Fr_2}{Fr_1}$ kN	ir	n_2 min ⁻¹	P_N kW	T_N kNm	$\frac{Fr_2}{Fr_1}$ kN		
1450	4.47	325	690	19.3	95.1 28.0	4.41	329	1036	28.6	119.5 37.4	4.57	317	1926	55.1			
1000		224	532	21.6			227	799	32.0			219	1328	55.1			
500		112	318	25.8			113	466	37.3			109	664	55.1			
1450	5.02	289	690	21.7	92.9 28.9	4.95	293	980	30.4	118.0 35.7	5.13	283	1926	61.9			
1000		199	533	24.3			202	756	34.0			195	1328	61.9			
500		100	318	29.0			101	466	41.9			97	664	61.9			
1450	5.67	256	692	24.6	89.9 29.7	5.60	259	979	34.3	114.4 36.8	5.79	250	1927	69.9			
1000		176	534	27.5			179	756	38.4			173	1329	69.9			
500		88	318	32.8			89	466	47.4			86	664	69.9			
1450	6.45	225	691	27.9	85.9 30.5	6.36	228	981	39.1	109.4 37.8	6.58	220	1927	79.4			
1000		155	533	31.2			157	756	43.7			152	1329	79.4			
500		78	318	37.2			79	465	53.7			76	665	79.4			
1450	7.38	196	692	32.0	99.9 31.3	7.29	199	980	44.7	127.9 38.9	7.03	206	1926	84.8			
1000		135	532	35.7			137	756	50.0			142	1328	84.8			
500		68	318	42.6			69	465	61.6			71	664	84.8			
1450	7.93	183	690	34.3	88.4 32.2	7.83	185	979	48.0	114.2 39.9	8.09	179	1927	97.6			
1000		126	533	38.4			128	756	53.7			124	1329	97.6			
500		63	318	45.8			64	465	66.1			62	665	97.6			
1450	9.23	157	692	40.0	80.0 33.0	9.11	159	978	55.8	104.3 41.0	8.71	167	1926	105			
1000		108	533	44.7			110	754	62.4			115	1328	105			
500		54	318	53.3			55	464	76.8			57	664	105			
1450	10.0	145	691	43.3	69.9 33.8	9.88	147	980	60.6	92.1 42.0	10.2	142	1926	123			
1000		100	532	48.4			101	755	67.7			98	1328	123			
500		50	318	57.8			51	464	83.3			49	664	123			
1450	10.9	133	691	47.2	78.4 34.6	10.8	135	975	65.7	102.8 43.1	11.1	131	1323	92.0			
1000		92	498	49.3			93	698	68.2			90	946	95.4			
500		46	258	51.1			46	361	70.6			45	490	98.8			
1450	11.7	124	484	35.5	110.5 35.5	12.4	117	650	50.6	139.8 44.1	12.8	114	888	71.0			
1000		85	373	39.7			80	500	56.5			78	685	79.4			
500		43	199	42.3			40	282	63.6			39	386	89.5			
1450	13.6	106	484	41.3	117.2 36.3	14.6	100	637	58.1	149.8 45.2	14.9	97	884	82.7			
1000		73	373	46.2			69	490	64.9			67	681	92.4			
500		37	199	49.2			34	281	74.5			33	386	105			
1450	16.1	90	484	48.8	104.5 37.1	15.9	91	678	67.4	137.0 46.2	16.3	89	959	97.7			
1000		62	344	50.3			63	482	69.5			61	676	99.9			
500		31	178	52.1			32	250	72.0			31	350	103			
1450	17.6	82	414	45.7	107.8 37.9	17.4	83	580	63.1	136.6 47.3	17.8	81	813	90.6			
1000		57	291	46.5			58	408	64.3			56	571	92.3			
500		28	151	48.2			29	211	66.5			28	295	95.5			
1450	19.4	75	345	41.9	117.2 38.8	19.1	76	484	57.9	149.8 48.3	19.6	74	677	83.1			
1000		52	242	42.7			52	340	59.0			51	476	84.6			
500		26	125	44.2			26	176	61.0			26	246	87.6			
1450	22.6	64	267	37.8	126.3 39.6	22.5	64	367	51.8	158.9 49.4	22.9	63	514	73.7			
1000		44	188	38.5			44	257	52.7			44	361	75.1			
500		22	97	39.9			22	133	54.6			22	187	77.7			
1450	24.7	59	267	41.4	123.4 40.4	24.7	59	366	56.6	157.4 50.4	25.1	58	513	80.6			
1000		40	188	42.2			40	258	57.7			40	361	82.1			
500		20	97	43.7			20	133	59.7			19.9	187	85.0			
1450	27.2	53	247	42.6	117.2 41.2	27.2	53	346	58.9	149.8 51.5	27.6	53	489	84.5			
1000		37	176	43.4			37	243	60.0			36	344	86.1			
500		18.4	91	44.9			18.4	126	62.1			18.4	178	89.1			
Potenze termiche - Thermal power - Thermische Grenzleistung (senza raffreddamento / Without cooling / ohne Kühlung)																	
252						304						368					



A richiesta / On request / Auf Anfrage



1.9 Prestazioni riduttori RXO-RXV

1.9 RXO-RXV gear unit ratings

1.9 Leistungen der RXO-V Getriebe

RX 700  ECE-19 PAM-22 708							RX 712  ECE-36 PAM-41					
$n_{1,1}$ min	ir	n_2 min ⁻¹	P _N kW	T _N Nm	Fr ₁ N	Fr ₂ N	ir	n_2 min ⁻¹	P _N kW	T _N Nm	Fr ₁ N	Fr ₂ N
2850	68.5	41.6	3.0	641.1	350	8000	60.8	46.9	5.8	1099	500	12500
1450		21.2	1.7	700.0	630	8000		23.8	3.2	1200	1000	12500
1000		14.6	1.2	710.5	630	8000		16.4	2.3	1218	1000	12500
500	86.4	7.3	0.6	710.5	630	8000	8.2	1.1	1218	1000	12500	
2850		33.0	2.4	641.1	350	8000	38.2	4.9	1145	500	12500	
1450		16.8	1.3	700.0	630	8000	19.5	2.7	1250	1000	12500	
1000	99.5	11.6	0.9	710.5	630	8000	13.4	1.9	1269	1000	12500	
500		5.8	0.5	710.5	630	8000	6.7	1.0	1269	1000	12500	
2850		28.6	2.1	641.1	350	8000	29.0	3.9	1191	500	12500	
1450	124.9	14.6	1.1	700.0	630	8000	14.7	2.2	1300	1000	12500	
1000		10.0	0.8	710.5	630	8000	10.2	1.5	1320	1000	12500	
500		5.0	0.4	710.5	630	8000	5.1	0.8	1320	1000	12500	
2850	143.1	22.8	1.7	659.4	250	8000	22.8	3.1	1209	400	12500	
1450		11.6	0.9	720.0	500	8000	11.6	1.7	1320	800	12500	
1000		8.0	0.7	730.8	500	8000	8.0	1.2	1340	800	12500	
500	186.6	4.0	0.3	730.8	500	8000	4.0	0.6	1340	800	12500	
2850		19.9	1.5	668.5	250	8000	20.0	2.8	1236	400	12500	
1450		10.1	0.8	730.0	500	8000	10.2	1.5	1350	800	12500	
1000	235.6	7.0	0.6	741.0	500	8000	7.0	1.1	1370	800	12500	
500		3.5	0.3	741.0	500	8000	3.5	0.5	1370	800	12500	
2850		15.3	1.1	668.5	250	8000	17.0	2.4	1282	400	12500	
1450	263.7	7.8	0.6	730.0	500	8000	8.6	1.4	1400	800	12500	
1000		5.4	0.4	741.0	500	8000	6.0	1.0	1421	800	12500	
500		2.7	0.2	741.0	500	8000	3.0	0.5	1421	800	12500	
2850	302.4	12.1	0.9	668.5	200	8000	14.1	2.0	1282	400	12500	
1450		6.2	0.5	730.0	400	8000	7.2	1.1	1400	800	12500	
1000		4.2	0.4	741.0	400	8000	4.9	0.8	1421	800	12500	
500	343.5	2.1	0.2	741.0	400	8000	2.5	0.4	1421	800	12500	
2850		10.8	0.8	668.5	200	8000	12.1	1.8	1282	315	12500	
1450		5.5	0.5	730.0	400	8000	6.2	1.0	1400	630	12500	
1000	378.2	3.8	0.3	741.0	400	8000	4.3	0.7	1421	630	12500	
500		1.9	0.2	741.0	400	8000	2.1	0.3	1421	630	12500	
2850		9.4	0.7	677.7	200	8000	11.0	1.6	1282	315	12500	
1450	433.6	4.8	0.4	740.0	400	8000	5.6	0.9	1400	630	12500	
1000		3.3	0.3	751.1	400	8000	3.8	0.6	1421	630	12500	
500		1.7	0.1	751.1	400	8000	1.9	0.3	1421	630	12500	
2850	500.2	8.3	0.6	641.1	200	8000	9.6	1.4	1282	315	12500	
1450		4.2	0.3	700.0	400	8000	4.9	0.8	1400	630	12500	
1000		2.9	0.2	710.5	400	8000	3.4	0.5	1421	630	12500	
500	578.3	1.5	0.1	710.5	400	8000	1.7	0.3	1421	630	12500	
2850		7.5	0.5	641.1	200	8000	9.4	1.3	1209	315	12500	
1450		3.8	0.3	700.0	400	8000	4.8	0.7	1320	630	12500	
1000	712	2.6	0.2	710.5	400	8000	3.3	0.5	1340	630	12500	
500		1.3	0.1	710.5	400	8000	1.6	0.2	1340	630	12500	
2850		6.6	0.4	604.4	200	8000	7.6	1.0	1209	315	12500	
1450	712	3.3	0.2	660.0	400	8000	3.9	0.6	1320	630	12500	
1000		2.3	0.2	669.9	400	8000	2.7	0.4	1340	630	12500	
500		1.2	0.1	669.9	400	8000	1.3	0.2	1340	630	12500	
2850	712	5.7	0.4	604.4	200	8000	6.7	0.9	1209	315	12500	
1450		2.9	0.2	660.0	400	8000	3.4	0.5	1320	630	12500	
1000		2.0	0.2	669.9	400	8000	2.4	0.4	1340	630	12500	
500	712	1.0	0.1	669.9	400	8000	1.2	0.2	1340	630	12500	
2850		4.9	0.3	604.4	200	8000	5.0	0.7	1209	315	12500	
1450		2.5	0.2	660.0	400	8000	2.5	0.4	1320	630	12500	
1000	712	1.7	0.1	669.9	400	8000	1.8	0.3	1340	630	12500	
500		0.9	0.1	669.9	400	8000	0.9	0.1	1340	630	12500	



Potenze termiche / Thermal power / Termische Grenzleistung P_{IN} [kW]
(senza raffreddamento / Without cooling / ohne Kühlung)

12 18

* Nei rapporti contrassegnati non è disponibile la versione uscita con albero cavo ø 45.

* Hollow output shaft ø 45 not available for ratios marked with this symbol.

* Bei den gekennzeichneten Übersetzungsverhältnissen ist die Version „Abtrieb mit Hohlwelle ø 45“ nicht verfügbar.

RX 700  ECE-66 PAM-76 716							RX 720  ECE-124 PAM-131 720					
$n_{1,1}$ min	ir	n_2 min ⁻¹	P_N kW	T_N Nm	Fr_1 N	Fr_2 N	ir	n_2 min-1	P_N kW	T_N Nm	Fr_1 N	Fr_2 N

2850	61,9	46,0	11,4	2198	800	20000	46,0	61,9	26,8	3846	1600	35000
1450		23,4	6,3	2400	1600	20000		31,5	14,9	4200	2500	35000
1000		16,1	4,4	2436	1600	20000		21,7	10,4	4263	2500	35000
500	74,5	8,1	2,2	2436	1600	20000	10,9	5,2	4263	2500	35000	
2850		38,2	10,3	2381	800	20000	52,0	26,8	4579	1600	35000	
1450		19,5	5,7	2600	1600	20000	26,4	14,9	5000	2500	35000	
1000	100,1	13,4	4,0	2639	1600	20000	18,2	10,4	5075	2500	35000	
500		6,7	2,0	2639	1600	20000	9,1	5,2	5075	2500	35000	
2850		28,5	7,9	2473	800	20000	42,6	22,0	4579	1600	35000	
1450	125,2	14,5	4,4	2700	1600	20000	21,7	12,2	5000	2500	35000	
1000		10,0	3,1	2741	1600	20000	14,9	8,5	5075	2500	35000	
500		5,0	1,5	2741	1600	20000	7,5	4,3	5075	2500	35000	
2850	145,0	22,8	6,6	2564	625	20000	35,8	18,5	4579	1600	35000	
1450		11,6	3,7	2800	1250	20000	18,2	10,3	5000	2500	35000	
1000		8,0	2,6	2842	1250	20000	12,6	7,2	5075	2500	35000	
500	177,7	4,0	1,3	2842	1250	20000	6,3	3,6	5075	2500	35000	
2850		19,6	6,1	2747	625	20000	27,8	14,3	4579	1600	35000	
1450		10,0	3,4	3000	1250	20000	14,1	8,0	5000	2500	35000	
1000	206,0	6,9	2,4	3045	1250	20000	9,8	5,6	5075	2500	35000	
500		3,4	1,2	3045	1250	20000	4,9	2,8	5075	2500	35000	
2850		16,0	5,0	2747	625	20000	22,8	11,8	4579	1600	35000	
1450	238,7	8,2	2,8	3000	1250	20000	11,6	6,5	5000	2500	35000	
1000		5,6	1,9	3045	1250	20000	8,0	4,6	5075	2500	35000	
500		2,8	1,0	3045	1250	20000	4,0	2,3	5075	2500	35000	
2850	267,6	13,8	4,3	2747	625	20000	17,9	9,2	4579	1600	35000	
1450		7,0	2,4	3000	1250	20000	9,1	5,1	5000	2500	35000	
1000		4,9	1,7	3045	1250	20000	6,3	3,6	5075	2500	35000	
500	310,2	2,4	0,8	3045	1250	20000	3,1	1,8	5075	2500	35000	
2850		11,9	3,6	2656	500	20000	13,9	7,1	4579	1600	35000	
1450		6,1	2,0	2900	1000	20000	7,0	4,0	5000	2500	35000	
1000	342,3	4,2	1,4	2944	1000	20000	4,9	2,8	5075	2500	35000	
500		2,1	0,7	2944	1000	20000	2,4	1,4	5075	2500	35000	
2850		10,6	3,1	2564	500	20000	11,4	5,9	4579	1600	35000	
1450	383,8	5,4	1,7	2800	1000	20000	5,8	3,3	5000	2500	35000	
1000		3,7	1,2	2842	1000	20000	4,0	2,3	5075	2500	35000	
500		1,9	0,6	2842	1000	20000	2,0	1,1	5075	2500	35000	
2850	444,8	9,2	2,7	2564	500	20000	9,0	4,7	4579	1600	35000	
1450		4,7	1,5	2800	1000	20000	4,6	2,6	5000	2500	35000	
1000		3,2	1,0	2842	1000	20000	3,2	1,8	5075	2500	35000	
500	561,2	1,6	0,5	2842	1000	20000	1,6	0,9	5075	2500	35000	
2850		8,3	2,4	2564	500	20000	7,7	4,0	4579	1600	35000	
1450		4,2	1,3	2800	1000	20000	3,9	2,2	5000	2500	35000	
1000	569,4	2,9	0,9	2842	1000	20000	2,7	1,5	5075	2500	35000	
500		1,5	0,5	2842	1000	20000	1,3	0,8	5075	2500	35000	
2850		7,4	2,1	2518	500	20000	6,3	3,2	4579	1600	35000	
1450	561,2	3,8	1,2	2750	1000	20000	3,2	1,8	5000	2500	35000	
1000		2,6	0,8	2791	1000	20000	2,2	1,3	5075	2500	35000	
500		1,3	0,4	2791	1000	20000	1,1	0,6	5075	2500	35000	
2850	561,2	6,4	1,8	2473	500	20000	5,0	2,6	4579	1600	35000	
1450		3,3	1,0	2700	1000	20000	2,5	1,4	5000	2500	35000	
1000		2,2	0,7	2741	1000	20000	1,8	1,0	5075	2500	35000	
500	561,2	1,1	0,3	2741	1000	20000	0,9	0,5	5075	2500	35000	
2850		5,1	1,4	2473	500	20000						
1450		2,6	0,8	2700	1000	20000						
1000	1,8	0,5	2740	1000	20000							
500	0,9	0,3	2740	1000	20000							

Potenze termiche / Thermal power / Termische Grenzleistung P_{IN} [kW]
(senza raffreddamento / Without cooling / ohne Kühlung)

26

35

1.9 Prestazioni riduttori RXO-RXV

1.9 RXO-RXV gear unit ratings

1.9 Leistungen der RXO-V Getriebe

RX 800 98 802						131 804					183 806				
n_1 min ⁻¹	ir	n_2 min ⁻¹	P_N kW	T_N kNm	$\frac{Fr_2}{Fr_1}$ kN	ir	n_2 min ⁻¹	P_N kW	T_N kNm	$\frac{Fr_2}{Fr_1}$ kN	ir	n_2 min ⁻¹	P_N kW	T_N kNm	$\frac{Fr_2}{Fr_1}$ kN
1450	19.4	75	27	3.2	12 1.8	19.4	75	39	4.6	16 2.0	20.5	71	56	7.0	21 3.1
1000		52	18.6	3.2			52	27	4.7			49	39	7.1	
500		26	9.3	3.2			26	13.6	4.7			24	20	7.4	
1450	21.9	66	24	3.2	12 1.8	21.9	66	34	4.6	16 2.0	21.8	67	52	7.0	20 3.1
1000		46	17.0	3.3			46	24	4.7			46	37	7.1	
500		23	8.7	3.4			23	12.6	4.9			23	19.1	7.4	
1450	24.9	58	22	3.3	12 1.9	24.9	58	31	4.7	15 2.2	24.6	59	46	7.0	19 3.2
1000		40	14.9	3.3			40	22	4.8			41	33	7.2	
500		20	7.7	3.4			20	11.1	4.9			20	16.9	7.4	
1450	28.5	51	18.9	3.3	12 1.9	30.6	47	25	4.7	15 2.2	28.0	52	41	7.1	19 3.2
1000		35	13.4	3.4			33	17.7	4.8			36	29	7.2	
500		17.6	6.9	3.5			16.4	9.2	5.0			17.9	15.1	7.5	
1450	30.6	47	17.6	3.3	11 2	32.9	44	23	4.7	15 2.2	30.0	48	39	7.1	19 3.4
1000		33	12.5	3.4			30	16.4	4.8			33	27	7.2	
500		16.3	6.4	3.5			15.2	8.5	5.0			16.7	14.1	7.5	
1450	32.9	44	16.3	3.3	11 2	38.5	38	20	4.8	15 2.3	34.6	42	34	7.2	19 3.4
1000		30	11.6	3.4			26	14.3	4.9			29	24	7.3	
500		15.2	6.0	3.5			13.0	7.3	5.0			14.4	12.3	7.6	
1450	38.6	38	13.9	3.3	11 2.1	41.9	35	18.7	4.8	15 2.3	37.4	39	31	7.2	19 3.6
1000		26	9.9	3.4			24	13.1	4.9			27	22	7.3	
500		13.0	5.1	3.5			11.9	6.7	5.0			13.4	11.4	7.6	
1450	46.0	32	12.1	3.4	11 2.1	45.9	32	17.1	4.8	15 2.3	44.1	33	27	7.2	19 3.6
1000		22	8.3	3.4			22	12.0	4.9			23	18.9	7.4	
500		10.9	4.3	3.5			10.9	6.1	5.0			11.3	9.7	7.6	
1450	49.6	29	11.2	3.4	11 2.1	49.5	29	15.8	4.8	15 2.3	52.1	28	23	7.3	19 3.6
1000		20	7.7	3.4			20	11.1	4.9			19.2	16.0	7.4	
500		10.1	4.0	3.5			10.1	5.7	5.0			9.6	8.2	7.6	
1450	58.1	25	9.5	3.4	11 2.1	58.0	25	13.8	4.9	15 2.3	56.3	26	21	7.3	19 3.6
1000		17.2	6.8	3.5			17.2	9.7	5.0			17.8	15.0	7.5	
500		8.6	3.4	3.5			8.6	4.9	5.0			8.9	7.6	7.6	
1450	63.3	23	8.8	3.4	11 2.2	63.1	23	12.7	4.9	15 2.5	66.3	22	18.2	7.4	19 3.8
1000		15.8	6.2	3.5			15.8	8.9	5.0			15.1	12.7	7.5	
500		7.9	3.1	3.5			7.9	4.5	5.0			7.5	6.4	7.6	
1450	69.2	21	8.0	3.4	11 2.2	69.1	21	11.6	4.9	15 2.5	72.5	20	16.4	7.4	19 3.8
1000		14.4	5.7	3.5			14.5	8.1	5.0			13.8	11.8	7.6	
500		7.2	2.8	3.5			7.2	4.1	5.0			6.9	5.9	7.6	
1450	81.5	17.8	7.0	3.5	11 2.2	81.3	17.8	9.8	4.9	15 2.5	79.8	18.2	15.3	7.5	19 3.8
1000		12.3	4.8	3.5			12.3	6.9	5.0			12.5	10.7	7.6	
500		6.1	2.4	3.5			6.1	3.5	5.0			6.3	5.4	7.6	
1450	88.7	16.3	6.4	3.5	11 2.2	88.5	16.4	9.2	5.0	15 2.5	93.0	15.6	13.1	7.5	19 3.8
1000		11.3	4.4	3.5			11.3	6.4	5.0			10.8	9.2	7.6	
500		5.6	2.2	3.5			5.7	3.2	5.0			5.4	4.6	7.6	
1450	97.1	14.9	5.9	3.5	11 2.2	96.8	15.0	8.4	5.0	15 2.5	102	14.3	12.2	7.6	19 3.8
1000		10.3	4.1	3.5			10.3	5.8	5.0			9.8	8.4	7.6	
500		5.1	2.0	3.5			5.2	2.9	5.0			4.9	4.2	7.6	
1450	107*	13.6	5.3	3.5	11 2.2	107*	13.6	7.7	5.0	15 2.5	112	13.0	11.1	7.6	19 3.8
1000		9.4	3.7	3.5			9.4	5.3	5.0			8.9	7.6	7.6	
500		4.7	1.8	3.5			4.7	2.6	5.0			4.5	3.8	7.6	
1450	118*	12.2	4.8	3.5	11 2.2	118*	12.3	6.9	5.0	15 2.5	124*	11.7	10.0	7.6	19 3.8
1000		8.5	3.3	3.5			8.5	4.8	5.0			8.1	6.9	7.6	
500		4.2	1.7	3.5			4.2	2.4	5.0			4.0	3.5	7.6	
Potenze termiche - Thermal power - Thermische Grenzleistung															
(senza raffreddamento / Without cooling / ohne Kühlung)															
24						30					40				

* Nei rapporti contrassegnati non è disponibile la versione uscita con albero cavo "C"- "UB"- "B"- "CD".



* Hollow output shaft "C"- "UB"- "B"- "CD" not available for ratios marked with this symbol.

* Bei den gekennzeichneten Übersetzungsverhältnissen ist die Version "Abtrieb mit Hohlwelle" "C"- "UB"- "B"- "CD" nicht verfügbar.

1.9 Prestazioni riduttori RXO-RXV

1.9 RXO-RXV gear unit ratings

1.9 Leistungen der RXO-V Getriebe

RX 800  247 808						RX 352  352 810					RX 477  477 812				
n_1 min ⁻¹	ir	n_2 min ⁻¹	P _N kW	T _N kNm	Fr ₂ Fr ₁ kN	ir	n_2 min ⁻¹	P _N kW	T _N kNm	Fr ₂ Fr ₁ kN	ir	n_2 min ⁻¹	P _N kW	T _N kNm	Fr ₂ Fr ₁ kN
1450	19.7	74	82	9.9	38 5.8	20.1	72	110	13.6	48 6.8	19.1	76	172	20.1	51 9.3
1000		51	58	10.1			50	78	13.9			52	121	20.5	
500		25	30	10.5			25	40	14.4			26	63	21.3	
1450	22.3	65	73	10.0	36 5.8	22.7	64	99	13.7	46 6.8	21.5	67	154	20.3	51 9.3
1000		45	52	10.2			44	69	14.0			46	108	20.7	
500		22	27	10.5			22	36	14.4			23	56	21.4	
1450	23.7	61	69	10.0	34 6.1	24.2	60	93	13.7	44 7.0	24.5	59	136	20.4	49 9.5
1000		42	48	10.2			41	65	14.0			41	96	20.8	
500		21	25	10.6			21	34	14.5			20	49	21.5	
1450	27.1	54	61	10.1	34 6.1	27.6	53	82	13.8	44 7.0	28.0	52	119	20.5	49 9.5
1000		37	43	10.3			36	58	14.1			36	84	20.9	
500		18.5	22	10.6			18.1	30	14.6			18	44	21.7	
1450	29.0	50	57	10.1	34 6.3	29.5	49	77	13.9	44 7.2	30.1	48	112	20.6	49 9.7
1000		34	40	10.3			34	54	14.1			33	78	21.0	
500		17.2	21	10.7			16.9	28	14.6			17.8	41	21.7	
1450	33.5	43	50	10.2	34 6.3	34.1	42	67	14.0	44 7.2	35.0	41	97	20.8	49 9.7
1000		30	35	10.4			29	47	14.2			29	68	21.2	
500		14.9	18.1	10.8			14.6	24	14.7			14.3	35	21.9	
1450	39.3	37	43	10.3	34 6.6	40.0	36	57	14.1	44 7.5	41.4	35	82	20.9	49 10.0
1000		25	30	10.5			25	40	14.4			24	58	21.3	
500		12.7	15.4	10.8			12.5	21	14.8			12.1	30	21.9	
1450	46.8	31	36	10.4	34 6.6	43.6	33	53	14.2	44 7.5	45.3	32	76	21.0	49 10.0
1000		21	25	10.6			23	37	14.4			22	53	21.4	
500		10.7	13.0	10.8			11.5	19.1	14.8			11.0	27	21.9	
1450	50.5	29	34	10.4	34 6.6	51.4	28	45	14.3	44 7.5	52.7	28	66	21.2	49 10.0
1000		19.8	24	10.6			19.5	32	14.5			19.0	46	21.6	
500		9.9	12.0	10.8			9.7	16.2	14.8			9.5	23	21.9	
1450	59.2	25	29	10.5	34 6.6	60.2	24	39	14.4	44 7.5	57.2	25	61	21.3	49 10.0
1000		16.9	20	10.7			16.6	27	14.7			17.5	43	21.7	
500		8.5	10.3	10.8			8.3	13.8	14.8			8.7	22	21.9	
1450	64.4	23	27	10.5	34 6.9	65.6	22	36	14.4	44 7.7	62.3	23	56	21.4	49 10.4
1000		15.5	18.7	10.7			15.3	25	14.7			16.1	39	21.8	
500		7.8	9.4	10.8			7.6	12.7	14.8			8.0	19.8	21.9	
1450	70.5	21	25	10.6	34 6.9	71.7	20	33	14.5	44 7.7	68.1	21	51	21.5	49 10.4
1000		14.2	17.2	10.8			13.9	23	14.8			14.7	36	21.9	
500		7.1	8.6	10.8			7.0	11.6	14.8			7.3	18.1	21.9	
1450	77.6	18.7	22	10.6	34 6.9	84.4	17.2	28	14.6	44 7.7	80.2	18.1	44	21.7	49 10.4
1000		12.9	15.7	10.8			11.8	19.7	14.8			12.5	31	21.9	
500		6.4	7.8	10.8			5.9	9.9	14.8			6.2	15.4	21.9	
1450	90.3	16.0	19.3	10.7	34 6.9	92.0	15.8	26	14.7	44 7.7	87.3	16.6	41	21.7	49 10.4
1000		11.1	13.4	10.8			10.9	18.1	14.8			11.5	28	21.9	
500		5.5	6.7	10.8			5.4	9.1	14.8			5.7	14.1	21.9	
1450	98.9	14.7	17.8	10.8	34 6.9	101	14.4	24	14.8	44 7.7	95.6	15.2	37	21.8	49 10.4
1000		10.1	12.3	10.8			9.9	16.5	14.8			10.5	26	21.9	
500		5.1	6.1	10.8			5.0	8.3	14.8			5.2	12.9	21.9	
1450	109	13.3	16.1	10.8	34 6.9	111*	13.1	22	14.8	44 7.7	105*	13.8	34	21.9	49 10.4
1000		9.2	11.2	10.8			9.0	15.0	14.8			9.5	23	21.9	
500		4.6	5.6	10.8			4.5	7.5	14.8			4.8	11.7	21.9	
1450	121	12.0	14.6	10.8	34 6.9	123*	11.8	19.7	14.8	44 7.7	117*	12.4	31	21.9	49 10.4
1000		8.3	10.1	10.8			8.2	13.6	14.8			8.6	21	21.9	
500		4.1	5.0	10.8			4.1	6.8	14.8			4.3	10.6	21.9	

Potenze termiche - Thermal power - Thermische Grenzleistung
(senza raffreddamento / Without cooling / ohne Kühlung)

52





65

82

* Nei rapporti contrassegnati non è disponibile la versione uscita con albero cavo "C"- "UB"- "B"- "CD".

* Hollow output shaft "C"- "UB"- "B"- "CD" not available for ratios marked with this symbol.

* Bei den gekennzeichneten Übersetzungsverhältnissen ist die Version "Abtrieb mit Hohlwelle" "C"- "UB"- "B"- "CD" nicht verfügbar.

RX 800  659 814						 917 816					 1281 818					 1789 820				
n_1 min ⁻¹	ir	n_2 min ⁻¹	P_N kW	T_N kNm	Fr_2 Fr_1 kN	ir	n_2 min ⁻¹	P_N kW	T_N kNm	Fr_2 Fr_1 kN	ir	n_2 min ⁻¹	P_N kW	T_N kNm	Fr_2 Fr_1 kN	ir	n_2 min ⁻¹	P_N kW	T_N kNm	Fr_2 Fr_1 kN
1450	19.4	75	232	27.5	60 11.5	19.4	75	331	39.4	75 14.7	19.4	745	490	58.1	103 16.7	19.7	74	661	79.9	145 19.3
1000		52	163	28.0			52	233	40.2			52	338	58.2			51	464	81.4	
500		26	84	29.0			26	121	41.6			26	169	58.2			25	240	84.2	
1450	21.9	66	206	27.7	60 11.5	21.9	66	296	39.7	72 14.7	21.8	67	438	58.5	103 16.7	22.3	65	588	80.3	145 19.3
1000		46	145	28.2			46	208	40.4			46	308	59.6			45	414	81.9	
500		23	75	29.2			23	107	41.8			23	156	60.4			22	214	84.7	
1450	24.9	58	183	27.9	58 11.7	24.9	58	262	39.9	70 14.8	24.6	59	390	58.8	100 17.1	23.7	61	554	80.6	142 19.8
1000		40	128	28.4			40	184	40.7			41	274	60.0			42	389	82.1	
500		20	66	29.4			20	95	42.1			20	142	62.1			21	201	85.0	
1450	28.5	51	160	28.0	58 11.7	26.6	55	246	40.0	70 14.8	28.0	52	345	59.2	100 17.1	27.1	54	489	81.1	142 19.8
1000		35	113	28.6			38	173	40.8			36	242	60.3			37	344	82.7	
500		17.6	58	29.6			18.8	89	42.2			17.9	125	62.5			18.5	178	85.6	
1450	30.6	47	150	28.1	58 12.0	30.6	47	215	40.3	70 15.1	30.0	48	323	59.4	100 17.6	31.1	47	428	81.7	142 20.2
1000		33	106	28.7			33	151	41.1			33	227	60.5			32	300	83.2	
500		16	55	29.7			16.4	78	42.5			16.7	118	62.7			16.1	156	86.2	
1450	32.9	44	140	28.3	58 12.0	32.9	44	201	40.5	70 15.1	34.6	42	282	59.9	100 17.6	36.3	40	370	82.3	142 20.2
1000		30	98	28.8			30	141	41.2			29	198	61.0			28	260	83.9	
500		15	51	29.8			15.2	73	42.7			14.4	102	63.1			13.8	135	86.8	
1450	38.6	38	120	28.5	58 12.2	38.5	38	173	40.8	70 15.5	37.4	39	262	60.1	100 18.0	39.3	37	343	82.7	142 20.7
1000		26	84	29.0			26	121	41.6			27	184	61.2			25	241	84.2	
500		13.0	44	29.9			13.0	62	42.8			13.4	95	63.2			12.7	124	86.8	
1450	46.0	32	102	28.7	58 12.2	45.9	32	146	41.2	70 15.5	44.1	33	224	60.6	100 18.0	46.8	31	290	83.4	142 20.7
1000		22	72	29.3			22	103	41.9			23	157	61.7			21	204	85.0	
500		10.9	37	29.9			10.9	52	42.8			11.3	81	63.2			10.7	104	86.8	
1450	49.6	29	95	28.8	58 12.2	49.5	29	136	41.3	70 15.5	52.1	28	191	61.1	100 18.0	54.5	27	251	84.0	142 20.7
1000		20	67	29.4			20	96	42.1			19	134	62.2			18.3	177	85.6	
500		10.1	34	29.9			10	49	42.8			9.6	68	63.2			9.2	89	86.8	
1450	58.1	25	82	29.1	58 12.2	58.0	25	117	41.6	70 15.5	56.3	26	178	61.3	80 18.0	59.2	25	233	84.4	142 20.7
1000		17.2	57	29.6			17	82	42.4			17.8	125	62.5			16.9	164	86.0	
500		8.6	29	29.9			8.6	42	42.8			8.9	63	63.2			8.5	83	86.8	
1450	63.3	23	75	29.2	58 12.4	63.1	23	108	41.8	70 15.7	66.3	22	152	61.8	100 18.9	64.4	23	214	84.7	142 21.6
1000		15.8	53	29.7			15.8	76	42.6			15.1	107	63.0			15.5	151	86.3	
500		7.9	27	29.9			7.9	38	42.8			7.5	54	63.2			7.8	76	86.8	
1450	69.2	21	69	29.3	58 12.4	69.1	21	99	42.0	70 15.7	72.5	20	140	62.1	100 18.9	70.5	21	197	85.1	142 21.6
1000		14.4	49	29.9			14.5	70	42.8			13.8	98	63.2			14.2	138	86.7	
500		7.2	24	29.9			7.2	35	42.8			6.9	49	63.2			7.1	69	86.8	
1450	81.5	17.8	59	29.6	58 12.4	81.3	17.8	85	42.3	70 15.7	78.9	18.4	129	62.4	100 18.9	83.0	17.5	169	85.8	142 21.6
1000		12.3	41	29.9			12.3	59	42.8			12.7	90	63.2			12.1	118	86.8	
500		6.1	21	29.9			6.1	30	42.8			6.3	45	63.2			6.0	59	86.8	
1450	88.7	16.3	55	29.7	58 12.4	88.5	16.4	78	42.5	70 15.7	93.0	15.6	110	62.9	100 18.9	90.3	16.0	156	86.2	142 21.6
1000		11.3	38	29.9			11.3	54	42.8			10.8	76	63.2			11.1	108	86.8	
500		5.6	19.0	29.9			5.7	27	42.8			5.4	38	63.2			5.5	54	86.8	
1450	97.1	14.9	50	29.8	58 12.4	96.8	15.0	72	42.7	70 15.7	102	14.3	101	63.2	100 18.9	98.9	14.7	143	86.6	142 21.6
1000		10.3	35	29.9			10.3	50	42.8			9.8	70	63.2			10.1	99	86.8	
500		5.2	17.3	29.9			5.2	25	42.8			4.9	35	63.2			5.1	49	86.8	
1450	107*	13.6	46	29.9	58 12.4	107*	13.6	66	42.8	70 15.7	112*	13.0	92	63.2	100 18.9	109*	13.3	130	86.8	142 21.6
1000		9.4	31	29.9			9.4	45	42.8			8.9	64	63.2			9.2	90	86.8	
500		4.7	15.7	29.9			4.7	23	42.8			4.5	32	63.2			4.6	45	86.8	
1450	118*	12.2	41	29.9	58 12.4	118*	12.3	59	42.8	70 15.7	124*	11.7	83	63.2	100 18.9	121*	12.0	117	86.8	142 21.6
1000		8.4	28	29.9			8.5	41	42.8			8.1	57	63.2			8.3	81	86.8	
500		4.2	14.2	29.9			4.2	20.4	42.8			4.0	29	63.2			4.1	40	86.8	
Potenze termiche - Thermal power - Thermische Grenzleistung (senza raffreddamento / Without cooling / ohne Kühlung)																				
102						127					165					205				

* Nei rapporti contrassegnati non è disponibile la versione uscita con albero cavo "C"-UB"-B"-CD".

* Hollow output shaft "C"-UB"-B"-CD" not available for ratios marked with this symbol.

* Bei den gekennzeichneten Übersetzungsverhältnissen ist die Version "Abtrieb mit Hohlwelle" "C"-UB"-B"-CD" nicht verfügbar.

1.9 Prestazioni riduttori RX0-RXV

1.9 RX0-RXV gear unit ratings

1.9 Leistungen der RX0-V Getriebe

RX 800 G-2711 Kg A-2499 822						G-3711 Kg A-2972 824						G-4661 Kg A-3911 826						Kg 6211 828					
n ₁ min ⁻¹	ir	n ₂ min ⁻¹	P _N kW	T _N kNm	Fr ₂ Fr ₁ kN	ir	n ₂ min ⁻¹	P _N kW	T _N kNm	Fr ₂ Fr ₁ kN	ir	n ₂ min ⁻¹	P _N kW	T _N kNm	Fr ₂ Fr ₁ kN	ir	n ₂ min ⁻¹	P _N kW	T _N kNm	Fr ₂ Fr ₁ kN			
1450	20.1	72	887	109	182 27.0	19.4	75	1369	163	205 35.0	19.5	75	1813	216	240 40.5	19.8	73	2312	281	281	281		
1000		50	624	111			52	956	165			51	1251	216			51	1595	281				
500		25	323	115			26	478	165			26	625	216			25	797	281				
1450	22.7	64	790	110	182 27.0	21.9	66	1219	164	205 35.0	22.0	66	1655	223	240 40.5	22.3	65	2312	317	317	317		
1000		44	555	112			46	857	167			46	1163	227			45	1595	317				
500		22	287	116			23	444	173			23	602	235			22	797	317				
1450	25.8	56	700	111	178 27.9	24.9	58	1079	165	200 36.0	25.0	58	1466	225	235 42.3	25.4	57	2052	319	319	319		
1000		39	492	113			40	758	168			40	1030	229			39	1442	325				
500		19.4	254	117			20	393	174			20	533	237			19.7	746	337				
1450	27.6	53	657	111	178 27.9	28.6	51	949	166	200 36.0	28.6	51	1288	226	235 42.3	27.1	54	1926	320	320	320		
1000		36.3	461	113			35	667	169			35	905	230			37	1353	326				
500		18.1	239	117			17.5	345	175			17.5	469	239			18.4	701	338				
1450	29.5	49	615	111	178 28.8	30.7	47	887	167	200 36.9	30.7	47	1204	227	235 44.1	31.2	47	1687	323	323	323		
1000		34	432	113			33	623	170			33	846	231			32	1185	329				
500		16.9	224	117			16.3	323	176			16.3	438	239			16.0	613	340				
1450	34.1	43	536	112	178 28.8	35.7	41	768	168	200 36.9	33.1	44	1122	228	235 44.1	33.6	43	1572	324	324	324		
1000		29	376	114			28	539	171			30	788	232			40	1105	330				
500		14.6	195	118			14.0	279	177			15.1	408	240			14.9	572	341				
1450	40.0	36	461	113	178 29.7	38.7	38	711	169	200 37.8	38.8	37	965	230	235 45.9	39.3	37	1353	326	326	326		
1000		25	324	115			26	500	172			26	678	234			25	951	332				
500		12.5	167	119			12.9	257	177			12.9	349	241			12.7	489	342				
1450	43.6	33	425	114	178 29.7	46.1	31	602	170	200 37.8	42.3	34	890	231	235 45.9	46.8	31	1146	329	329	329		
1000		23	299	116			22	423	173			24	625	235			21	805	335				
500		11.5	153	119			10.8	216	177			11.8	321	241			10.7	411	342				
1450	52.5	28	356	115	178 29.7	52.7	28	530	171	200 37.8	50.9	29	746	233	235 45.9	49.2	30	1093	330	330	330		
1000		19.1	250	117			19.0	372	175			19.7	524	237			20	768	336				
500		9.5	127	119			9.5	189	177			9.8	266	241			10.2	391	342				
1450	60.2	24	313	115	178 29.7	57.2	25	491	172	200 37.8	57.2	25	667	234	235 45.9	57.6	25	941	333	333	333		
1000		16.6	219	118			17.5	345	175			17.5	469	239			17.3	661	339				
500		8.3	111	119			8.7	174	177			8.7	237	241			8.7	334	342				
1450	65.6	22	288	116	178 30.6	68.1	21	415	174	200 39.6	62.3	23	615	235	235 47.7	62.8	23	868	334	334	334		
1000		15.3	202	118			14.7	292	177			16.0	432	240			15.9	610	340				
500		7.6	102	119			7.3	146	177			8.0	217	241			8.0	306	342				
1450	71.7	20	265	116	178 30.6	75.0	19.3	379	174	200 39.6	68.2	21	564	236	235 47.7	68.7	21	797	336	336	336		
1000		13.9	186	119			13.3	265	177			14.7	397	241			14.6	560	342				
500		7.0	93	119			6.7	133	177			7.3	199	241			7.3	280	342				
1450	79.0	18.4	242	117	178 30.6	80.2	18.1	356	175	200 39.6	75.1	19.3	515	237	235 47.7	81.2	17.9	680	338	338	338		
1000		12.7	169	119			12.5	248	177			13.3	361	241			12.3	474	342				
500		6.3	85	119			6.2	124	177			6.7	181	241			6.2	237	342				
1450	92.0	15.8	209	118	178 30.6	95.6	15.2	301	177	200 39.6	88.6	16.4	440	239	235 47.7	88.4	16.4	627	340	340	340		
1000		10.9	145	119			10.5	208	177			11.3	306	241			11.3	435	342				
500		5.4	73	119			5.2	104	177			5.7	153	241			5.7	218	342				
1450	101	14.4	192	118	178 30.6	105	13.8	274	177	200 39.6	107	13.6	368	241	235 47.7	96.7	15.0	576	341	341	341		
1000		9.9	133	119			9.5	189	177			9.4	254	241			10.3	398	342				
500		5.0	66	119			4.8	95	177			4.7	127	241			5.2	199	342				
1450	111	13.1	175	119	178 30.6	117*	12.4	248	177	200 39.6	118*	12.3	333	241	235 47.7	106*	13.6	524	342	342	342		
1000		9.0	121	119			8.6	171	177			8.5	229	241			9.4	362	342				
500		4.5	60	119			4.3	85	177			4.2	115	241			4.7	181	342				
1450	123*	11.8	158	119	178 30.6	130*	11.1	195	156	200 39.6	132*	11.0	274	222	235 47.7	118*	12.3	473	342	342	342		
1000		8.2	109	119			7.7	137	159			7.6	192	226			8.5	326	342				
500		4.1	54	119			3.8	71	165			3.8	99.5	234			4.2	163	342				

A richiesta / On request / Auf Anfrage



Potenze termiche - Thermal power - Thermische Grenzleistung
(senza raffreddamento / Without cooling / ohne Kühlung)

248

306

368

445

* Nei rapporti contrassegnati non è disponibile la versione uscita con albero cavo "C"- "UB"- "B"- "CD".

* Hollow output shaft "C"- "UB"- "B"- "CD" not available for ratios marked with this symbol.

* Bei den gekennzeichneten Übersetzungsverhältnissen ist die Version "Abtrieb mit Hohlwelle" "C"- "UB"- "B"- "CD" nicht verfügbar.

RX 800 110 802						139 804					204 806					284 808				
n_1 min ⁻¹	ir	n_2 min ⁻¹	P _N kW	T _N kNm	Fr ₂ Fr ₁ kN	ir	n_2 min ⁻¹	P _N kW	T _N kNm	Fr ₂ Fr ₁ kN	ir	n_2 min ⁻¹	P _N kW	T _N kNm	Fr ₂ Fr ₁ kN	ir	n_2 min ⁻¹	P _N kW	T _N kNm	Fr ₂ Fr ₁ kN
1450	110	13.2	5.3	3.5	11 1.9	118	12.3	7.1	5.0	15 2.2	114	12.7	11.1	7.6	19.0 3.3	120	12.1	15.0	10.8	34.0 6.1
1000		9.1	3.6	3.5			8.5	4.9	5.0			8.8	7.7	7.6			8.3	10.3	10.8	
500		4.5	1.8	3.5			4.2	2.4	5.0			4.4	3.8	7.6			4.2	5.2	10.8	
1450	121	12.0	4.8	3.5	11 1.9	129	11.3	6.5	5.0	15 2.2	124	11.7	10.2	7.6	19.0 3.3	131	11.1	13.8	10.8	34.0 6.1
1000		8.3	3.3	3.5			7.8	4.5	5.0			8.1	7.0	7.6			7.7	9.5	10.8	
500		4.1	1.7	3.5			3.9	2.2	5.0			4.0	3.5	7.6			3.8	4.8	10.8	
1450	147	9.9	4.0	3.5	11 1.9	142	10.2	5.9	5.0	15 2.2	136	10.7	9.3	7.6	19.0 3.3	143	10.2	12.6	10.8	34.0 6.1
1000		6.8	2.7	3.5			7.1	4.1	5.0			7.4	6.4	7.6			7.0	8.7	10.8	
500		3.4	1.4	3.5			3.5	2.0	5.0			3.7	3.2	7.6			3.5	4.3	10.8	
1450	168	8.6	3.5	3.5	11 1.9	163	8.9	5.1	5.0	15 2.2	168	8.6	7.5	7.6	19.0 3.3	165	8.8	10.9	10.8	34.0 6.1
1000		5.9	2.4	3.5			6.1	3.5	5.0			6.0	5.2	7.6			6.1	7.5	10.8	
500		3.0	1.2	3.5			3.1	1.8	5.0			3.0	2.6	7.6			3.0	3.8	10.8	
1450	181	8.0	3.2	3.5	11 1.9	175	8.3	4.7	5.0	15 2.2	181	8.0	7.0	7.6	19.0 3.3	194	7.5	9.3	10.8	34.0 6.1
1000		5.5	2.2	3.5			5.7	3.3	5.0			5.5	4.8	7.6			5.2	6.4	10.8	
500		2.8	1.1	3.5			2.8	1.6	5.0			2.8	2.4	7.6			2.6	3.2	10.8	
1450	195	7.4	3.0	3.5	11 1.9	205	7.1	4.1	5.0	15 2.2	214	6.8	5.9	7.6	19.0 3.3	211	6.9	8.5	10.8	34.0 6.1
1000		5.1	2.1	3.5			4.9	2.8	5.0			4.7	4.1	7.6			4.7	5.9	10.8	
500		2.6	1.0	3.5			2.4	1.4	5.0			2.3	2.0	7.6			2.4	2.9	10.8	
1450	228	6.4	2.6	3.5	11 1.9	224	6.5	3.7	5.0	15 2.2	234	6.2	5.4	7.6	19.0 3.3	231	6.3	7.8	10.8	34.0 6.1
1000		4.4	1.8	3.5			4.5	2.6	5.0			4.3	3.7	7.6			4.3	5.4	10.8	
500		2.2	0.88	3.5			2.2	1.3	5.0			2.1	1.9	7.6			2.2	2.7	10.8	
1450	248	5.8	2.3	3.5	11 1.9	264	5.5	3.2	5.0	15 2.2	257	5.6	4.9	7.6	19.0 3.3	254	5.7	7.1	10.8	34.0 6.1
1000		4.0	1.6	3.5			3.8	2.2	5.0			3.9	3.4	7.6			3.9	4.9	10.8	
500		2.0	0.81	3.5			1.9	1.1	5.0			1.9	1.7	7.6			2.0	2.4	10.8	
1450	272	5.3	2.1	3.5	11 2.2	309	4.7	2.7	5.0	15 2.5	273	5.3	4.6	7.6	19.0 3.8	291	5.0	6.2	10.8	34.0 6.9
1000		3.7	1.5	3.5			3.2	1.9	5.0			3.7	3.2	7.6			3.4	4.3	10.8	
500		1.8	0.74	3.5			1.6	0.93	5.0			1.8	1.6	7.6			1.7	2.1	10.8	
1450	293	4.9	2.0	3.5	11 2.2	337	4.3	2.5	5.0	15 2.5	321	4.5	3.9	7.6	19.0 3.8	317	4.6	5.7	10.8	34.0 6.9
1000		3.4	1.4	3.5			3.0	1.7	5.0			3.1	2.7	7.6			3.2	3.9	10.8	
500		1.7	0.69	3.5			1.5	0.85	5.0			1.6	1.4	7.6			1.6	2.0	10.8	
1450	343	4.2	1.7	3.5	11 2.2	368	3.9	2.3	5.0	15 2.5	351	4.1	3.6	7.6	19.0 3.8	347	4.2	5.2	10.8	34.0 6.9
1000		2.9	1.2	3.5			2.7	1.6	5.0			2.8	2.5	7.6			2.9	3.6	10.8	
500		1.5	0.59	3.5			1.4	0.78	5.0			1.4	1.2	7.6			1.4	1.8	10.8	
1450	409	3.5	1.4	3.5	11 2.2	370	3.9	2.2	5.0	15 2.5	387	3.8	3.3	7.6	19.0 3.8	382	3.8	4.7	10.8	34.0 6.9
1000		2.4	0.98	3.5			2.7	1.6	5.0			2.6	2.3	7.6			2.6	3.2	10.8	
500		1.2	0.49	3.5			1.4	0.78	5.0			1.3	1.1	7.6			1.3	1.6	10.8	
1450	481	3.0	1.2	3.5	11 2.2	434	3.3	1.9	5.0	15 2.5	451	3.2	2.8	7.6	19.0 3.8	445	3.3	4.0	10.8	34.0 6.9
1000		2.1	0.83	3.5			2.3	1.3	5.0			2.2	1.9	7.6			2.2	2.8	10.8	
500		1.0	0.42	3.5			1.2	0.66	5.0			1.1	0.97	7.6			1.1	1.4	10.8	
1450	524	2.8	1.1	3.5	11 2.2	517	2.8	1.6	5.0	15 2.5	493	2.9	2.6	7.6	19.0 3.8	487	3.0	3.7	10.8	34.0 6.9
1000		1.9	0.77	3.5			1.9	1.1	5.0			2.0	1.8	7.6			2.1	2.5	10.8	
500		0.95	0.38	3.5			0.97	0.56	5.0			1.0	0.89	7.6			1.0	1.3	10.8	
1450	574	2.5	1.0	3.5	11 2.2	568*	2.6	1.5	5.0	15 2.5	542	2.7	2.3	7.6	19.0 3.8	536	2.7	3.4	10.8	34.0 6.9
1000		1.7	0.70	3.5			1.8	1.0	5.0			1.8	1.6	7.6			1.9	2.3	10.8	
500		0.87	0.35	3.5			0.88	0.51	5.0			0.92	0.80	7.6			0.93	1.2	10.8	
1450	631*	2.3	0.92	3.5	12 2.5	629*	2.3	1.3	5.0	16.0 2.9	600*	2.4	2.1	7.6	21.0 4.4	593	2.4	3.0	10.8	38.0 7.8
1000		1.6	0.64	3.5			1.6	0.91	5.0			1.7	1.5	7.6			1.7	2.1	10.8	
500		0.79	0.32	3.5			0.79	0.46	5.0			0.83	0.73	7.6			0.84	1.04	10.8	
1450	700*	2.1	0.83	3.5	12 2.5	697*	2.1	1.2	5.0	16.0 2.9	661*	2.2	1.9	7.6	21.0 4.4	653	2.2	2.8	10.8	38.0 7.8
1000		1.4	0.57	3.5			1.4	0.82	5.0			1.5	1.3	7.6			1.5	1.9	10.8	
500		0.71	0.29	3.5			0.72	0.41	5.0			0.76	0.66	7.6			0.77	0.95	10.8	

Potenze termiche - Thermal power - Thermische Grenzleistung
 (senza raffreddamento / Without cooling / ohne Kühlung)

14 17 23 30

* Nei rapporti contrassegnati non è disponibile la versione uscita con albero cavo "C"- "UB"- "B"- "CD".

* Hollow output shaft "C"- "UB"- "B"- "CD" not available for ratios marked with this symbol.

* Bei den gekennzeichneten Übersetzungsverhältnissen ist die Version "Abtrieb mit Hohlwelle" "C"- "UB"- "B"- "CD" nicht verfügbar.

1.9 Prestazioni riduttori RXO-RXV

1.9 RXO-RXV gear unit ratings

1.9 Leistungen der RXO-V Getriebe

RX 800 KG 393 810						KG 545 812					KG 769 814					KG 1056 816					
n_1	ir	n_2	P _N	T _N	$\frac{Fr_2}{Fr_1}$	ir	n_2	P _N	T _N	$\frac{Fr_2}{Fr_1}$	ir	n_2	P _N	T _N	$\frac{Fr_2}{Fr_1}$	ir	n_2	P _N	T _N	$\frac{Fr_2}{Fr_1}$	
min ⁻¹		min ⁻¹	kW	kNm	kN		min ⁻¹	kW	kNm	kN		min ⁻¹	kW	kNm	kN		min ⁻¹	kW	kNm	kN	
1450	116	12.5	21.3	14.8	44.0	114	12.7	32.3	21.9	49.0	110	13.2	45	29.9	58.0	118	12.3	61	42.8	70.0	
1000		8.6	14.6	14.8	7.2		8.7	21.8	21.9	9.7		9.1	31	29.9	12.1		8.5	42	42.8	15.4	
500		4.3	7.3	14.8			4.4	11.0	21.9			4.5	15.6	29.9			4.2	21	42.8		
1450	128	11.3	19.3	14.8	44.0	124	11.7	29.4	21.9	49.0	121	12.0	41	29.9	58.0	129	11.3	55	42.8	70.0	
1000		7.8	13.3	14.8	7.2		8.1	20.3	21.9	9.7		8.3	28	29.9	12.1		7.8	38	42.8	15.4	
500		3.9	6.7	14.8			4.0	10.1	21.9			4.1	14.2	29.9			3.9	19.1	42.8		
1450	140	10.4	17.7	14.8	44.0	136	10.6	26.6	21.9	49.0	147	9.9	34	29.9	58.0	142	10.2	50	42.8	70.0	
1000		7.1	12.2	14.8	7.2		7.3	18.5	21.9	9.7		6.8	23	29.9	12.1		7.1	35	42.8	15.4	
500		3.6	6.1	14.8			3.7	9.3	21.9			3.4	11.7	29.9			3.5	17.3	42.8		
1450	154	9.4	16.0	14.8	44.0	166	8.8	22	21.9	49.0	168	8.6	30	29.9	58.0	163	8.9	44	42.8	70.0	
1000		6.5	11.0	14.8	7.2		6.0	15.2	21.9	9.7		5.9	20	29.9	12.1		6.1	30	42.8	15.4	
500		3.3	5.5	14.8			3.0	7.6	21.9			3.0	10.2	29.9			3.1	15.1	42.8		
1450	165	8.8	15.0	14.8	44.0	178	8.1	20	21.9	49.0	181	8.0	28	29.9	58.0	175	8.3	41	42.8	70.0	
1000		6.1	10.3	14.8	7.2		5.6	14.1	21.9	9.7		5.5	19.0	29.9	12.1		5.7	28	42.8	15.4	
500		3.0	5.2	14.8			2.8	7.1	21.9			2.8	9.5	29.9			2.8	14.0	42.8		
1450	191	7.6	12.9	14.8	44.0	207	7.0	17.6	21.9	49.0	195	7.4	26	29.9	58.0	205	7.1	35	42.8	70.0	
1000		5.2	8.9	14.8	7.2		4.8	12.1	21.9	9.7		5.1	17.6	29.9	12.1		4.9	24	42.8	15.4	
500		2.6	4.5	14.8			2.4	6.1	21.9			2.6	8.8	29.9			2.4	12.0	42.8		
1450	223	6.5	11.0	14.8	44.0	225	6.5	16.2	21.9	49.0	228	6.4	22	29.9	58.0	224	6.5	32	42.8	70.0	
1000		4.5	7.6	14.8	7.2		4.5	11.2	21.9	9.7		4.4	15.0	29.9	12.1		4.5	22	42.8	15.4	
500		2.2	3.8	14.8			2.2	5.6	21.9			2.2	7.5	29.9			2.2	11.0	42.8		
1450	243	6.0	10.1	14.8	44.0	245	5.9	14.9	21.9	49.0	248	5.8	20	29.9	58.0	245	5.9	29	42.8	70.0	
1000		4.1	7.0	14.8	7.2		4.1	10.3	21.9	9.7		4.0	13.8	29.9	12.1		4.1	20	42.8	15.4	
500		2.1	3.5	14.8			2.0	5.1	21.9			2.0	6.9	29.9			2.0	10.0	42.8		
1450	287	5.1	8.6	14.8	44.0	268	5.4	13.6	21.9	49.0	272	5.3	18.3	29.9	58.0	264	5.5	27	42.8	70.0	
1000		3.5	5.9	14.8	7.8		3.7	9.4	21.9	10.6		3.7	12.6	29.9	12.8		3.8	18.6	42.8	16.3	
500		1.7	3.0	14.8			1.9	4.7	21.9			1.8	6.3	29.9			1.9	9.3	42.8		
1450	336	4.3	7.3	14.8	44.0	312	4.7	11.7	21.9	49.0	293	4.9	17.0	29.9	58.0	309	4.7	23	42.8	70.0	
1000		3.0	5.1	14.8	7.8		3.2	8.1	21.9	10.6		3.4	11.7	29.9	12.8		3.2	15.9	42.8	16.3	
500		1.5	2.5	14.8			1.6	4.0	21.9			1.7	5.9	29.9			1.6	7.9	42.8		
1450	366	4.0	6.7	14.8	44.0	368	3.9	9.9	21.9	49.0	343	4.2	14.5	29.9	58.0	368	3.9	19.3	42.8	70.0	
1000		2.7	4.6	14.8	7.8		2.7	6.8	21.9	10.6		2.9	10.0	29.9	12.8		2.7	13.3	42.8	16.3	
500		1.4	2.3	14.8			1.4	3.4	21.9			1.5	5.0	29.9			1.4	6.7	42.8		
1450	401	3.6	6.2	14.8	44.0	403	3.6	9.1	21.9	49.0	409	3.5	12.2	29.9	58.0	370	3.9	19.2	42.8	70.0	
1000		2.5	4.2	14.8	7.8		2.5	6.2	21.9	10.6		2.4	8.4	29.9	12.8		2.7	13.3	42.8	16.3	
500		1.2	2.1	14.8			1.2	3.1	21.9			1.2	4.2	29.9			1.4	6.6	42.8		
1450	471	3.1	5.2	14.8	44.0	437	3.3	8.3	21.9	49.0	481	3.0	10.3	29.9	58.0	434	3.3	16.4	42.8	70.0	
1000		2.1	3.6	14.8	7.8		2.3	5.8	21.9	10.6		2.1	7.1	29.9	12.8		2.3	11.3	42.8	16.3	
500		1.1	1.8	14.8			1.1	2.9	21.9			1.0	3.6	29.9			1.2	5.7	42.8		
1450	513	2.8	4.8	14.8	44.0	516	2.8	7.1	21.9	49.0	524	2.8	9.5	29.9	58.0	472	3.1	15.1	42.8	70.0	
1000		1.9	3.3	14.8	7.8		1.9	4.9	21.9	10.6		1.9	6.5	29.9	12.8		2.1	10.4	42.8	16.3	
500		0.97	1.7	14.8			0.97	2.4	21.9			0.95	3.3	29.9			1.1	5.2	42.8		
1450	562	2.6	4.4	14.8	44.0	565	2.6	6.5	21.9	49.0	574	2.5	8.7	29.9	58.0	568*	2.6	12.5	42.8	70.0	
1000		1.8	3.0	14.8	7.8		1.8	4.5	21.9	10.6		1.7	6.0	29.9	12.8		1.8	8.6	42.8	16.3	
500		0.89	1.5	14.8			0.89	2.2	21.9			0.87	3.0	29.9			0.88	4.3	42.8		
1450	618*	2.3	4.0	14.8	48.0	621*	2.3	5.9	21.9	53.0	631*	2.3	7.9	29.9	63.0	630*	2.3	11.3	42.8	75.0	
1000		1.6	2.7	14.8	8.7		1.6	4.0	21.9	11.6		1.6	5.4	29.9	14.1		1.6	7.8	42.8	17.8	
500		0.81	1.4	14.8			0.80	2.0	21.9			0.79	2.7	29.9			0.79	3.9	42.8		
1450	685*	2.1	3.6	14.8	48.0	689*	2.1	5.3	21.9	53.0	700*	2.1	7.1	29.9	63.0	697*	2.1	10.2	42.8	75.0	
1000		1.5	2.5	14.8	8.7		1.5	3.7	21.9	11.6		1.4	4.9	29.9	14.1		1.4	7.0	42.8	17.8	
500		0.73	1.2	14.8			0.73	1.8	21.9			0.71	2.5	29.9			0.72	3.5	42.8		
Potenze termiche - Thermal power - Thermische Grenzleistung (senza raffreddamento / Without cooling / ohne Kühlung)																					
38						49					61					77					

* Nei rapporti contrassegnati non è disponibile la versione uscita con albero cavo "C"- "UB"- "B"- "CD".

* Hollow output shaft "C"- "UB"- "B"- "CD" not available for ratios marked with this symbol.

* Bei den gekennzeichneten Übersetzungsverhältnissen ist die Version "Abtrieb mit Hohlwelle" "C"- "UB"- "B"- "CD" nicht verfügbar.

1.9 Prestazioni riduttori RXO-RXV

1.9 RXO-RXV gear unit ratings

1.9 Leistungen der RXO-V Getriebe

RX 800 G-5161 A-4941 826						7111 828						10511 830						13911 832											
n_1 min ⁻¹	ir	n_2 min ⁻¹	P _N kW	T _N kNm	Fr ₂ Fr ₁ kN	ir	n_2 min ⁻¹	P _N kW	T _N kNm	Fr ₂ Fr ₁ kN	ir	n_2 min ⁻¹	P _N kW	T _N kNm	Fr ₂ Fr ₁ kN	ir	n_2 min ⁻¹	P _N kW	T _N kNm	Fr ₂ Fr ₁ kN									
1450	118	12.3	341	241	235 42.7	110	13.1	517.6	342	272 54.0	117	12.4	720.6	505	350 67.0	104	13.9	1102.5	692	440 81.0									
1000		8.5	236	241			9.1	356.6	342			8.6	496.8	505			9.5	760.7	692										
500		4.2	118	241			4.6	178.3	342			4.2	248.9	505			4.8	380.4	692										
1450	129	11.3	312	241	235 42.7	131	11.0	434.2	342	272 54.0	128	11.4	658.8	505	350 67.0	122	11.9	941.2	692	440 81.0									
1000		7.8	215	241			7.7	299.4	342			7.9	454.0	505			8.2	649.3	692										
500		3.9	108	241			3.8	149.7	342			3.9	227.0	505			4.1	325.1	692										
1450	142	10.2	284	241	235 42.7	144	10.1	395.0	342	272 54.0	141	10.4	597.8	505	350 67.0	146	9.9	791.0	692	440 81.0									
1000		7.1	196	241			6.9	271.6	342			7.1	412.2	505			6.8	544.8	692										
500		3.5	98	241			3.4	135.8	342			3.5	206.1	505			3.5	272.4	692										
1450	168	8.6	238	241	235 42.7	160	9.1	356	342	272 54.0	156	9.3	540	505	350 67.0	160	9.1	718.5	692	440 81.0									
1000		5.9	164	241			6.3	246	342			6.4	372	505			6.2	495.1	692										
500		3.0	82	241			3.1	123	342			3.2	186	505			3.1	247.6	692										
1450	181	8.0	222	241	235 42.7	184	7.9	310	342	272 54.0	178	8.1	472	505	350 67.0	178	8.2	649	692	440 81.0									
1000		5.5	153	241			5.4	214	342			5.6	326	505			5.6	447	692										
500		2.8	77	241			2.7	107	342			2.8	163	505			2.8	224	692										
1450	195	7.4	206	241	235 42.7	198	7.3	288	342	272 54.0	206	7.1	409	505	350 67.0	191	7.6	604	692	440 81.0									
1000		5.1	142	241			5.1	198	342			4.9	282	505			5.2	417	692										
500		2.6	71	241			2.5	99	342			2.4	141	505			2.6	208	692										
1450	228	6.4	176	241	235 42.7	232	6.3	246	342	272 54.0	222	6.5	379	505	350 67.0	222	6.5	519	692	440 81.0									
1000		4.4	121	241			4.3	169	342			4.5	261	505			4.5	358	692										
500		2.2	61	241			2.2	85	342			2.3	131	505			2.3	179	692										
1450	248	5.8	161	241	235 42.7	253	5.7	226	342	272 54.0	241	6.0	350	505	350 67.0	241	6.0	479	692	440 81.0									
1000		4.0	111	241			4.0	156	342			4.2	241	505			4.2	330	692										
500		2.0	56	241			2.0	78	342			2.1	121	505			2.1	165	692										
1450	272	5.3	148	241	235 48.4	272	5.3	210	342	272 59.8	303	4.8	277	505	350 73.0	280	5.2	412	692	440 88.0									
1000		3.7	102	241			3.7	145	342			3.3	191	505			3.6	284	692										
500		1.8	51	241			1.8	72	342			1.6	96	505			1.8	142	692										
1450	293	4.9	137	241	235 48.4	293	5.0	195	342	272 59.8	328	4.4	257	505	350 73.0	325	4.5	354	692	440 88.0									
1000		3.4	94	241			3.4	134	342			3.1	177	505			3.1	244	692										
500		1.7	47	241			1.7	67	342			1.5	89	505			1.5	122	692										
1450	343	4.2	117	241	235 48.4	343	4.2	166	342	272 59.8	355	4.1	237	505	350 73.0	353	4.1	326	692	440 88.0									
1000		2.9	81	241			2.9	115	342			2.8	163	505			2.8	225	692										
500		1.5	40	241			1.5	57	342			1.4	82	505			1.4	113	692										
1450	374	3.9	107	241	235 48.4	373	3.9	153	342	272 59.8	422	3.4	199	505	350 73.0	421	3.4	274	692	440 88.0									
1000		2.7	74	241			2.7	105	342			2.4	137	505			2.4	189	692										
500		1.3	37	241			1.3	53	342			1.2	69	505			1.2	94	692										
1450	481	3.0	83	241	235 48.4	480	3.0	119	342	272 59.8	465	3.1	181	505	350 73.0	458	3.2	251	692	440 88.0									
1000		2.1	57	241			2.1	82	342			2.1	125	505			2.2	173	692										
500		1.0	29	241			1.0	41	342			1.1	62	505			1.1	87	692										
1450	524	2.8	77	241	235 48.4	523	2.8	109	342	272 59.8	504	2.9	167	505	350 73.0	497	2.9	232	692	440 88.0									
1000		1.9	53	241			1.9	75	342			2.0	115	505			2.0	160	692										
500		0.95	26	241			0.96	38	342			0.99	57	505			1.0	80	692										
1450	574	2.5	70	241	235 48.4	572	2.5	99	342	272 59.8	600	2.4	140	505	350 73.0	592	2.4	195	692	440 88.0									
1000		1.7	48	241			1.7	69	342			1.7	97	505			1.7	134	692										
500		0.87	24	241			0.87	34	342			0.83	48	505			0.84	67	692										
1450	631	2.3	64	241	250 53.5	630*	2.3	90	342	280 65.3	660	2.2	127	505	360 80.4	652	2.2	177	692	460 98.0									
1000		1.6	44	241			1.6	62	342			1.5	88	505			1.5	122	692										
500		0.79	22	241			0.79	31	342			0.76	44	505			0.77	61	692										
1450	700*	2.1	57	241	250 53.5	697*	2.1	82	342	280 65.3	731	2.0	115	505	360 80.4	722	2.0	160	692	460 98.0									
1000		1.4	40	241			1.4	56	342			1.4	79	505			1.4	110	692										
500		0.71	19.8	241			0.72	28	342			0.68	40	505			0.69	55	692										
Potenze termiche - Thermal power - Thermische Grenzleistung (senza raffreddamento / Without cooling / ohne Kühlung)																													
						236						289						365						440					

* Nei rapporti contrassegnati non è disponibile la versione uscita con albero cavo "C"- "UB"- "B"- "CD".

* Hollow output shaft "C"- "UB"- "B"- "CD" not available for ratios marked with this symbol.

* Bei den gekennzeichneten Übersetzungsverhältnissen ist die Version "Abtrieb mit Hohlwelle" "C"- "UB"- "B"- "CD" nicht verfügbar.

1.10 Momenti d'inerzia

1.10 Moments of inertia

1.10 Trägheitsmomente

RX 800 Series		RX03 - RXV3															
		802	804	806	808	810	812	814	816	818	820	822	824	826	828	830	832
ir	-	110.1	117.7	113.9	119.9	112.1	114	110.1	117.7	114	111.9	108	108.4	110.1	110	117	104
J1	kgm ²	0.0001	0.0015	0.0012	0.0014	0.0027	0.0042	0.0072	0.0129	0.0240	0.0414	0.0744	0.1312	0.2334	0.4142	0.7379	1.3133
ir	-	120.5	128.7	124.0	130.5	122.6	124	120.5	128.7	124	121.8	125	118.6	120.5	131	128	122
J1	kgm ²	0.0001	0.0010	0.0010	0.0012	0.0023	0.0038	0.0065	0.0115	0.0212	0.0368	0.0660	0.1166	0.2074	0.3683	0.6558	1.1673
ir	-	146.9	141.7	135.7	142.8	134.8	136	146.9	141.7	136	146.6	134	144.6	146.9	144	141	146
J1	kgm ²	0.0001	0.0007	0.0008	0.0010	0.0020	0.0033	0.0058	0.0103	0.0187	0.0328	0.0586	0.1037	0.1843	0.3275	0.5829	1.0375
ir	-	168.3	163.0	167.8	165.2	153.8	165.7	168.3	163.0	149.4	168.7	159	165.7	168.3	159.9	155.7	160
J1	kgm ²	0.0001	0.0005	0.0006	0.0009	0.0017	0.0029	0.0052	0.0092	0.0165	0.0292	0.0520	0.0921	0.1638	0.2912	0.5181	0.9221
ir	-	180.8	175.5	181.2	193.5	164.8	177.9	180.8	175.5	184.7	196.4	173	177.9	180.8	183.9	178.0	177.6
J1	kgm ²	0.0001	0.0003	0.0005	0.0008	0.0015	0.0026	0.0046	0.0082	0.0146	0.0259	0.0461	0.0819	0.1456	0.2589	0.4605	0.8196
ir	-	194.7	205.5	213.6	210.8	190.7	207.1	194.7	205.5	199.4	212.9	190.7	207.1	194.7	198.0	205.6	190.8
J1	kgm ²	0.0001	0.0002	0.0004	0.0007	0.0013	0.0023	0.0041	0.0073	0.0129	0.0230	0.0409	0.0728	0.1294	0.2302	0.4093	0.7285
ir	-	228.1	223.7	233.6	230.6	223.4	224.6	228.1	223.7	235.1	231.9	223.4	224.6	228.1	231.9	222.0	222.0
J1	kgm ²	0.0001	0.0002	0.0004	0.0006	0.0012	0.0021	0.0036	0.0065	0.0115	0.0205	0.0364	0.0647	0.1151	0.2046	0.3638	0.6475
ir	-	248.4	264.0	256.9	253.8	243.3	244.5	248.4	245.2	257.1	253.8	243.3	249.3	248.4	252.5	240.5	240.7
J1	kgm ²	0.0001	0.0002	0.0003	0.0006	0.0010	0.0018	0.0032	0.0057	0.0102	0.0182	0.0323	0.0575	0.1023	0.1819	0.3234	0.5756
ir	-	272.0	309.2	272.6	291.2	286.9	267.7	272.0	264.0	277.9	295.5	286.9	267.7	272.0	271.7	303.4	279.6
J1	kgm ²	0.0001	0.0002	0.0011	0.0003	0.0005	0.0009	0.0016	0.0029	0.0051	0.0162	0.0288	0.0511	0.0909	0.1617	0.2875	0.5117
ir	-	293.0	336.6	321.4	317.1	336.2	311.6	293.0	309.2	300.0	320.4	336.2	311.6	293.0	292.5	327.5	325.4
J1	kgm ²	0.0001	0.0002	0.0003	0.0005	0.0009	0.0015	0.0027	0.0048	0.0085	0.0151	0.0268	0.0476	0.0846	0.1505	0.2677	0.4765
ir	-	343.3	368.3	351.5	347.0	366.1	368.0	343.3	368.3	353.7	348.9	366.1	337.9	343.3	342.6	354.9	352.9
J1	kgm ²	0.0001	0.0001	0.0003	0.0004	0.0008	0.0014	0.0025	0.0044	0.0078	0.0139	0.0248	0.0441	0.0784	0.1394	0.2478	0.4410
ir	-	409.1	370.3	386.5	381.9	400.6	402.6	409.1	370.3	386.8	381.8	400.6	402.6	373.8	373.0	422.3	420.5
J1	kgm ²	0.0001	0.0001	0.0002	0.0004	0.0007	0.0013	0.0023	0.0041	0.0072	0.0128	0.0228	0.0405	0.0721	0.1282	0.2280	0.4058
ir	-	481.5	433.6	450.8	444.8	471.5	437.0	481.5	433.6	420.8	449.4	471.5	437.0	481.5	480.5	465.3	458.2
J1	kgm ²	0.0001	0.0001	0.0002	0.0004	0.0007	0.0012	0.0021	0.0037	0.0066	0.0117	0.0208	0.0370	0.0658	0.1171	0.2028	0.3371
ir	-	524.3	516.5	493.0	486.7	513.4	516.0	524.3	472.1	496.1	489.4	513.4	473.9	524.3	523.1	504.2	496.9
J1	kgm ²	0.0001	0.0001	0.0002	0.0003	0.0006	0.0011	0.0019	0.0034	0.0060	0.0106	0.0188	0.0335	0.0596	0.1059	0.1884	0.3353
ir	-	573.8	568.3	542.1	535.6	561.8	564.7	573.8	568.3	542.5	535.5	561.8	564.7	573.8	572.3	600.0	592.1
J1	kgm ²	0.0001	0.0001	0.0002	0.0003	0.0006	0.0011	0.0019	0.0034	0.0060	0.0106	0.0188	0.0335	0.0596	0.1059	0.1884	0.3353
ir	-	631.4	629.5	600.2	593.5	618.3	621.5	631.4	629.6	596.6	589.3	618.3	621.5	631.4	629.6	659.8	651.6
J1	kgm ²	0.0001	0.0001	0.0002	0.0003	0.0006	0.0010	0.0018	0.0032	0.0056	0.0100	0.0178	0.0317	0.0564	0.1003	0.1784	0.3175
ir	-	699.6	697.4	660.6	653.0	685.1	688.6	699.6	697.4	660.6	653.0	685.1	688.6	699.6	697.4	730.6	722.0
J1	kgm ²	0.0001	0.0001	0.0002	0.0003	0.0005	0.0010	0.0017	0.0030	0.0053	0.0095	0.0169	0.0300	0.0533	0.0948	0.1685	0.2999



RX 800 Series		RX04							
		802	804	806	808	810	812	814	816
ir	-	A richiesta On request Auf Anfrage							
J1	kgm ²								

704-708-712-716-720

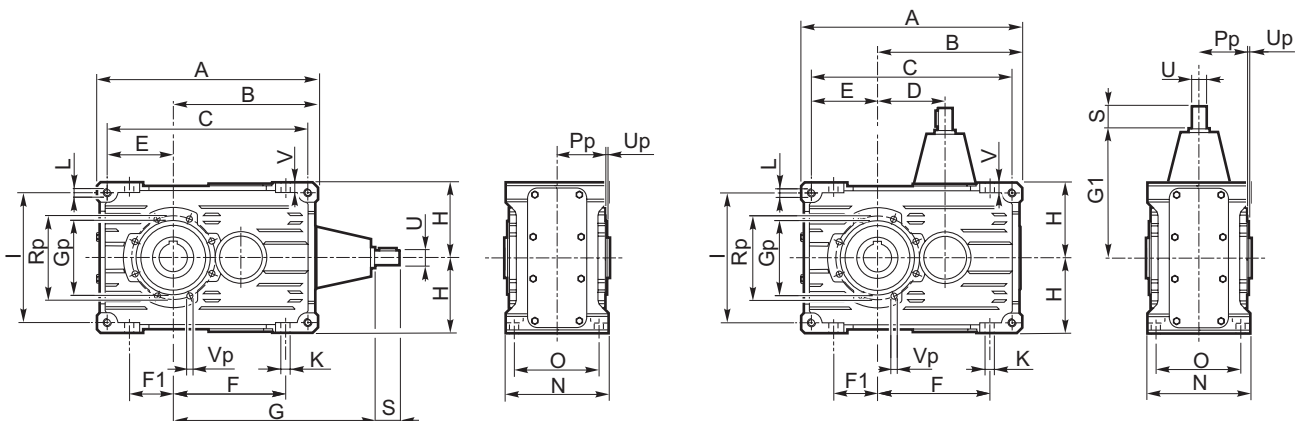

Esecuzione grafica / Shaft arrangement / Grafische Ausführung

Albero uscita / Output shaft / Abtriebswelle

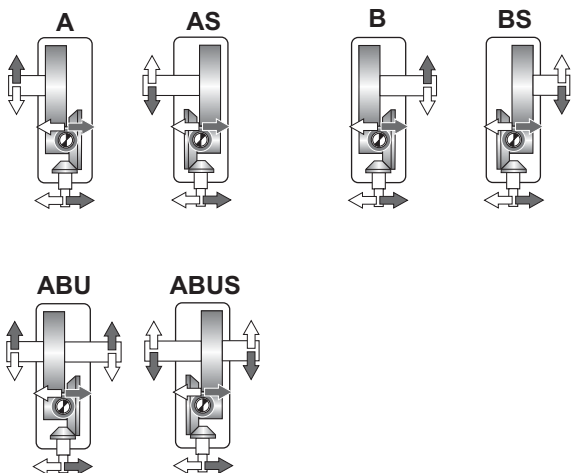

⇒ **N D FD**

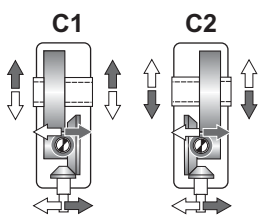
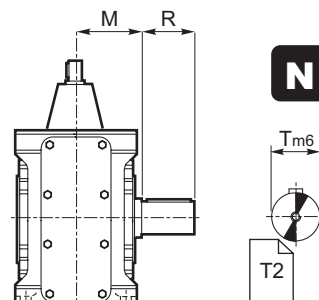

⇒ **C**

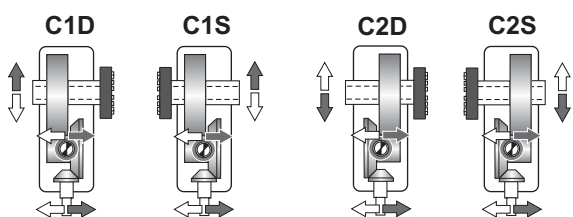
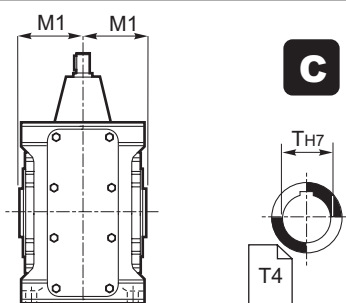

⇒ **UB B CD**

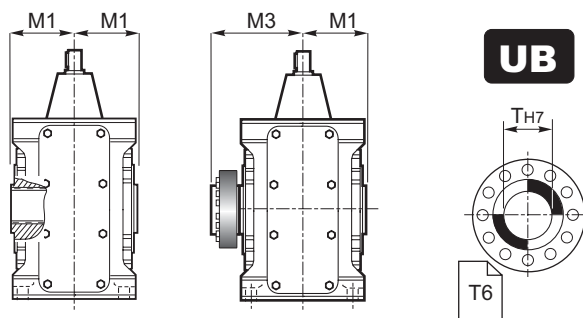

1.11 Dimensioni

1.11 Dimensions

1.11 Abmessungen

RX 700	Dimensioni generali / Dimensions / Allgemeine Abmessungen																				kg ECE	kg PAM
	A	B	C	D	E	F	F1	H h11	I	K	L	N h11	O	V	Gp	Pp	Rp	Up	Vp			
704	206	135	186	65	61	102	38	71	122	9	M8	112	90	10	75	51	85	3	M6	12.5	15.5	
708	262	172	237	80	77.5	134	52	90	155	11	M10	127	104	12	90	58.5	105	3	M8	20	25	
712	326	214	296	100	97	166	64	112	194	13	M12	150	125	15	110	70.5	125	3	M8	34	40	
716	407	267	371	127	122	209	82	140	244	15	M14	175	145	16	130	81	150	3	M10	58	70	
720	522.5	342.5	482.5	160	160	272.5	110	180	320	17	M16	215	180	17	170	103.5	200	4	M12	123	140	

	Albero entrata / Input shaft / Antriebswelle					Albero uscita / Output shaft / Abtriebswelle								
	ECE					N			C		UB		B	
	U	S	G	G1	T	R	M	T H7	M1	T H7	M1	M3		
704	14 j6	30	175	110	24 j6	50	62.5	24 (28)	57.5	25	57.8	82.5		
708	19 j6	40	210	130	32 k6	60	71	32 (30) (35)	65	35	65	95		
712	24 j6	50	260	160	42 k6	80	85.5	42 (40) (45)	77.5	45	77.5	112.5		
716	28 j6	60	317	190	55 k6	100	100	55 (50)	90	55	90	125		
720	38 k6	80	400	240	70 m6	125	122	70 (60)	110	70	110	154		

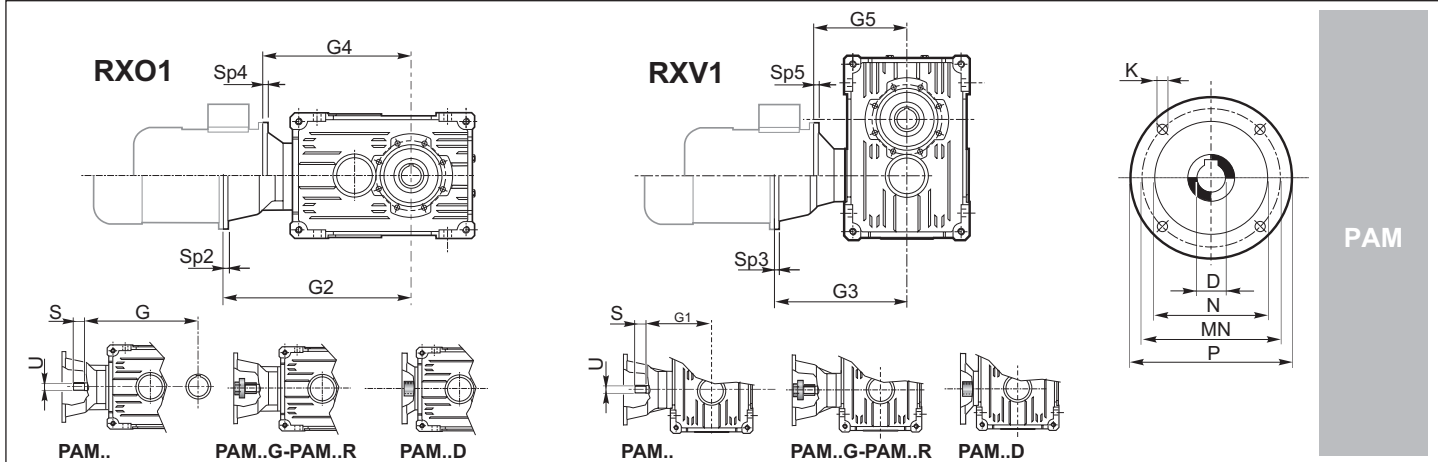

	IEC															
	63	71	80		90		100		112		132		160	180	200	
	B5	B5	B5	B14	B5	B14	B5	B14	B5	B14	B5	B14	B5	B5	B5	
D H7	11	14	19	19	24	24	28	28	28	28	38	38	42	48	55	
P	140	160	200	120	200	140	250	160	250	160	300	200	350	350	400	
MN	115	130	165	100	165	115	215	130	215	130	265	165	300	300	350	
N G6	95	110	130	80	130	95	180	110	180	110	230	130	250	250	300	
K	M8	M8	M10	M6	M10	M8	M12	M8	M12	M8	M12	M10	M16	M16	M16	
SP2/SP3/SP4/SP5	A richiesta / On request / Auf Anfrage															

RX01	Model	Shaft	Dimensions															
			G2	232	239	260	—	260	—	—	—	—	—	—	—	—	—	
704	PAM...G-R	G2	232	239	260	—	260	—	—	—	—	—	—	—	—	—		
	PAM..D	G4	205	205	205	205	205	205	—	—	—	—	—	—	—	—		
708	PAM...G-R	G2	—	284	305	—	305	—	315	—	315	—	—	—	—	—		
	PAM..D	G4	—	244	244	244	244	244	244	244	244	244	—	—	—	—		
712	PAM...G-R	G2	—	—	365	—	365	—	375	—	375	—	395	—	—	—		
	PAM..D	G4	—	—	311	—	311	—	311	—	311	—	311	311	—	—		
716	PAM...G-R	G2	—	—	—	—	—	—	442	—	442	—	—	—	—	—		
	PAM..D	G4	—	—	—	—	—	—	442	—	442	—	396*	—	405*	405*		
720	PAM...G-R	G2	—	—	—	—	—	—	—	—	—	—	—	—	—	—		
	PAM..D	G4	—	—	—	—	—	—	—	—	—	—	460*	—	469*	469*		

RXV1	Model	Shaft	Dimensions															
			G3	167	174	195	—	195	—	—	—	—	—	—	—	—	—	
704	PAM...G-R	G3	167	174	195	—	195	—	—	—	—	—	—	—	—	—		
	PAM..D	G5	140	140	140	140	140	140	—	—	—	—	—	—	—	—		
708	PAM...G-R	G3	—	204	225	—	225	—	235	—	235	—	—	—	—	—		
	PAM..D	G5	—	164	164	164	164	164	164	164	164	164	—	—	—	—		
712	PAM...G-R	G3	—	—	265	—	265	—	275	—	275	—	295	—	—	—		
	PAM..D	G5	—	—	211	—	211	—	211	—	211	—	211	211	—	—		
716	PAM...G-R	G3	—	—	—	—	—	—	316	—	316	—	—	—	—	—		
	PAM..D	G5	—	—	—	—	—	—	316	—	316	—	269*	—	278*	278*		
720	PAM...G-R	G3	—	—	—	—	—	—	—	—	—	—	—	—	—	—		
	PAM..D	G5	—	—	—	—	—	—	—	—	—	—	300*	—	309*	309*		

* Solo PAM...G - forniti con giunto tipo Rotex.

* Only PAM...G - come with Rotex coupling.

* nur PAM...G - Werden sie mit Kupplung Typ Rotex geliefert.

1.11 Dimensioni
Materiale Carcassa - "Ghisa"

1.11 Dimensions
Housing Material - "Cast Iron"

1.11 Abmessungen
Gehäusematerial - "Guss"

802-820

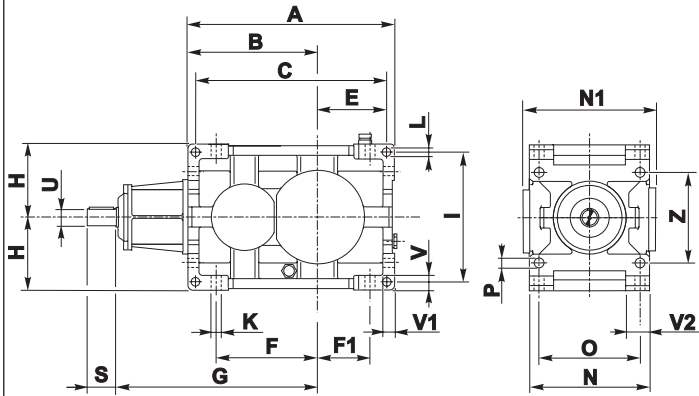

822-824

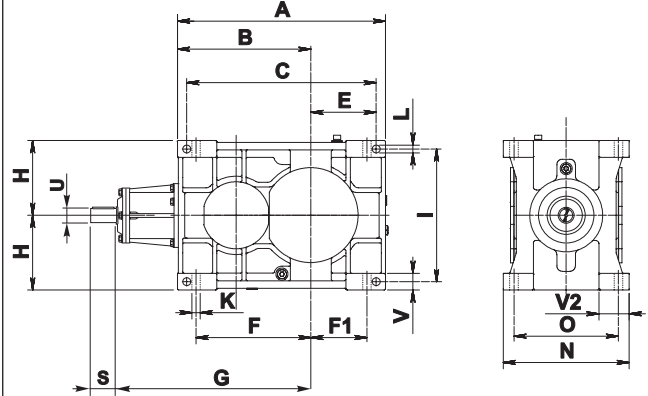

Esecuzione grafica / Shaft arrangement / Grafische Ausführung

Albero uscita / Output shaft / Abtriebswelle

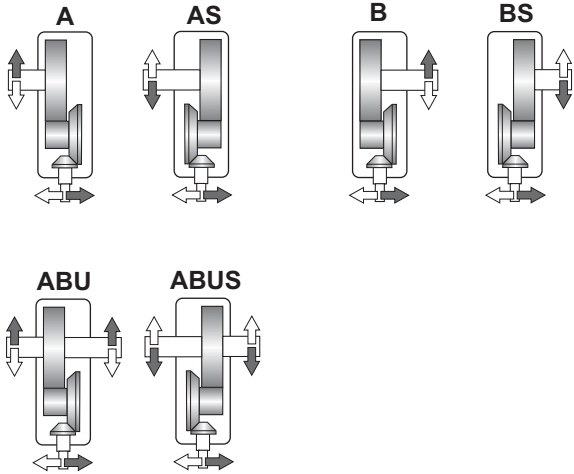

⇒ **N D FD Fn**

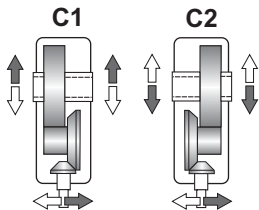
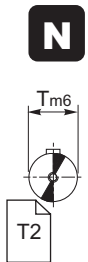
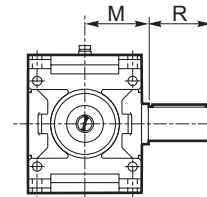

⇒ **C**

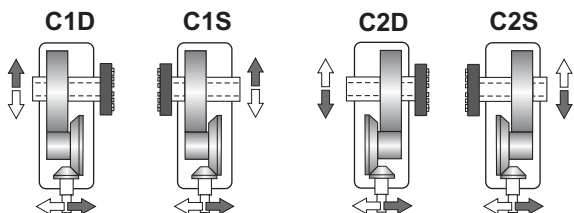
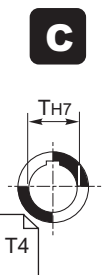
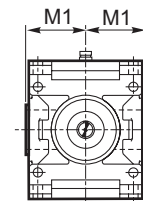

⇒ **UB B CD**

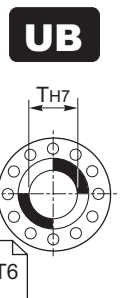
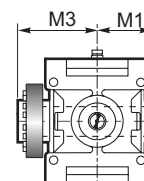
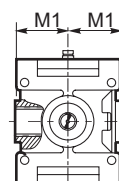





1.11 Dimensioni
Materiale Carcassa - "Ghisa"

1.11 Dimensions
Housing Material - "Cast Iron"

1.11 Abmessungen
Gehäusematerial - "Guss"

RX 800	Dimensioni generali / Dimensions / Allgemeine Abmessungen																		
	A	B	C	E	F	F1	H _{h11}	I	K	L	N _{h11}	N1	O	P	V	V1	V2	Z	Kg
802	355	225	327	116	175	90	125	224	18	14	213	219	180	18	25	20	44.5	160	82
804	402	252	370	134	196	104	140	250	20	16	237	241	200	20	28	22.5	49	180	114
806	455	285	421	153	222	117	160	280	22	18	269	271	225	22	32	25	56.5	200	154
808	510	320	472	171	250	130	180	320	25	20	297	299	250	25	36	28	59.5	224	211
810	570	360	530	190	280	145	200	360	27	22	335	327	280	27	40	32	67.5	250	292
812	645	405	600	217.5	315	160	225	400	30	24	379	380	315	30	45	36	78.5	280	387
814	715	450	665	240	350	180	250	450	33	27	427	424	355	33	50	40	89	320	561
816	805	505	749	272	393	203	280	500	36	30	479	473	400	36	56	45	96.5	360	782
818	910	570	846	308	445	230	315	560	39	35	541	497	450	39	63	50	114.5	400	1090
820	1020	640	948	344	500	260	355	638	42	39	599	550	500	42	70	56	124	450	1522
822	1115	715	1015	350	615	300	400	710	45	42	675	—	560	—	90	—	163	—	2126
824	1255	805	1145	395	675	320	450	800	48	45	761	—	630	—	100	—	176	—	2971

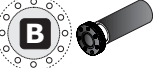
	Albero entrata / Input shaft / Antriebswelle			Albero uscita / Output shaft / Abtriebswelle								
	ECE 			N 			C 		UB 		B 	
	U	S	G	T m6	R	M	T H7	M1	T H7	M1	M3	
802	28 j6	50	350	60	112	109	60	109	60	109	170	
804	32 k6	56	390	70	125	121	70	121	70	121	192	
806	35 k6	63	440	80	140	137	80	137	80	137	215	
808	40 k6	70	495	90	160	151	90	151	90	151	246	
810	45 k6	80	555	100	180	170	100	170	100	170	266	
812	50 m6	90	625	110	200	192	110	192	110	192	302	
814	55 m6	100	700	125	225	216	125	216	125	216	335	
816	60 m6	112	780	140	250	242	140	242	140	242	370	
818	70 m6	125	880	160	280	273	160	273	160	273	422	
820	80 m6	140	990	180	315	302	180	302	180	302	477	
822	90 m6	160	1110	200	355	340	200	340	200	340	570	
824	100 m6	180	1250	220	400	383	220	383	220	383	617	

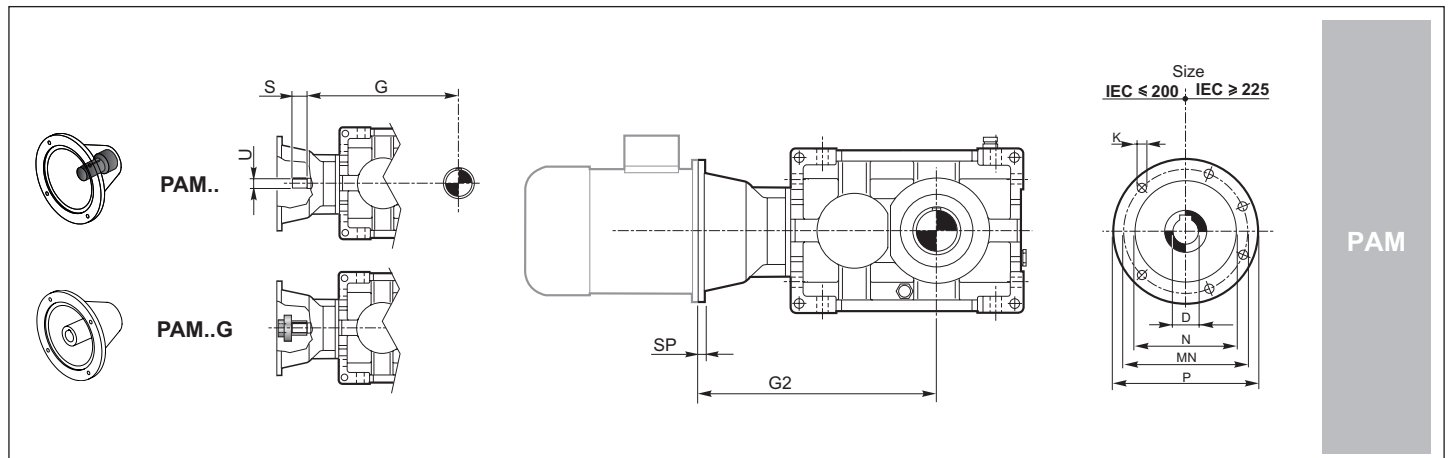

	IEC														
	71	80	90	100	112	132	160	180	200	225	250	280	315	355	
D H7	14	19	24	28	28	38	42	48	55	60	65	75	80	100	
P	160	200	200	250	250	300	350	350	400	450	550	550	660	800	
MN	130	165	165	215	215	265	300	300	350	400	500	500	600	740	
N G6	110	130	130	180	180	230	250	250	300	350	450	450	550	680	
K	M8	M10	M10	M12	M12	M12	M16	M16	M16	M16	M16	M16	M20	M20	
SP	12	12	12	14	14	16	18	18	20	20	20	20	24	30	
G2	802			464	464	484	514	514	514						
	804					530	560	560	560	590					
	806					587	617	617	617	647					
	808						679	679	679	709	709	709			
	810							749	749	779	779	779	809		
	812							829	829	859	859	859	889		
	814									944	944	944	974	1014	
	816									1036	1036	1036	1066	1106	
	818										1149	1149	1179	1219	
	820											1274	1304	1344	

A richiesta / On request / Auf Anfrage

1.11 Dimensioni
Materiale Carcassa - "Acciaio"

1.11 Dimensions
Housing Material - "Steel"

1.11 Abmessungen
Gehäusematerial - "Stahl"

802-814

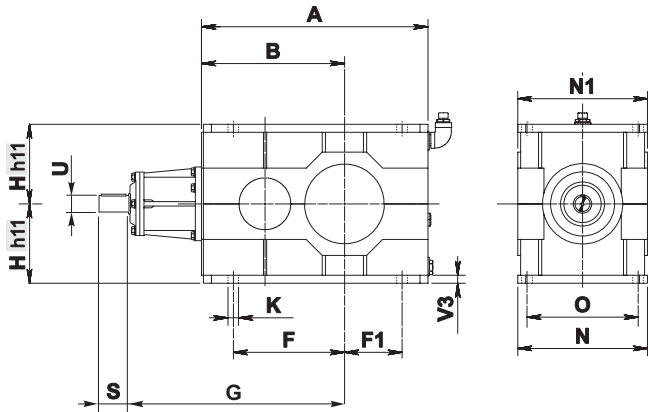

816-824

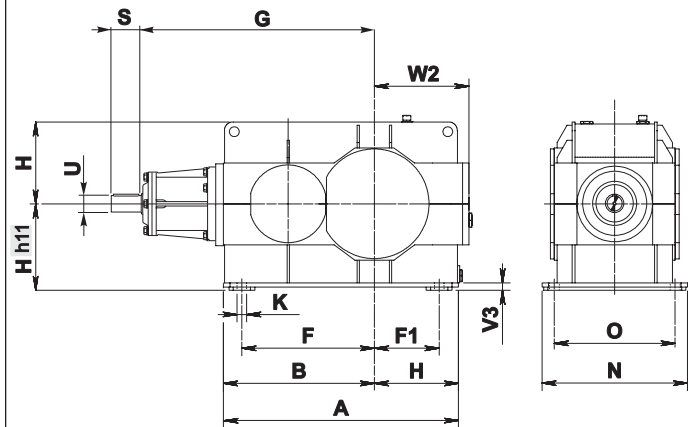

Esecuzione grafica / Shaft arrangement / Grafische Ausführung

Albero uscita / Output shaft / Abtriebswelle

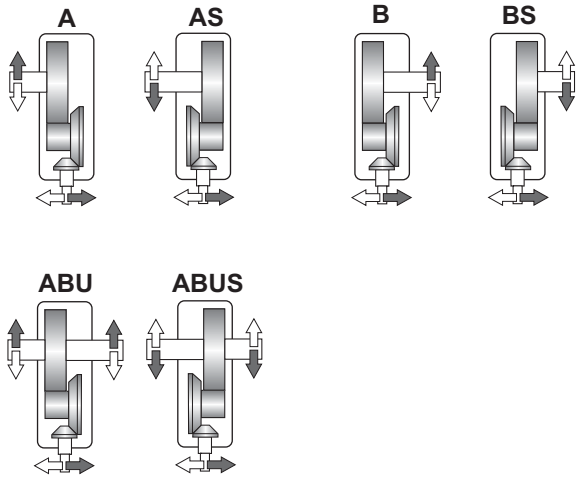

⇒ **N D FD Fn**

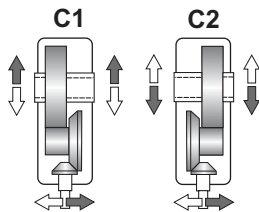
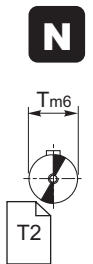
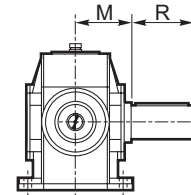

⇒ **C**

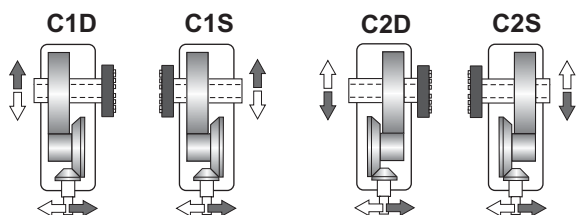
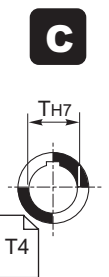
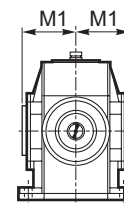

⇒ **UB B CD**

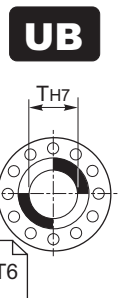
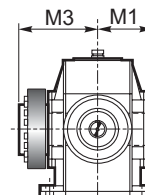
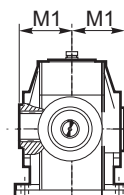



1.11 Dimensioni
Materiale Carcassa - "Acciaio"

1.11 Dimensions
Housing Material - "Steel"

1.11 Abmessungen
Gehäusematerial - "Stahl"

RX 800	Dimensioni generali / Dimensions / Allgemeine Abmessungen											
	A	B	F	F1	H	K	N	N1	O	W2	V3	ka
802	355	225	175	90	125	18	213	218	180	-	10	82
804	402	252	196	104	140	20	237	241	200	-	12	114
806	455	285	222	117	160	22	269	266	225	-	15	154
808	510	320	250	130	180	25	297	299	250	-	15	211
810	570	360	280	145	200	27	327	327	280	-	20	292
812	645	405	315	160	225	30	380	376	315	-	20	387
814	715	450	350	180	250	33	427	420	355	-	20	561
816	775	495	393	203	280	36	480	-	400	305	30	782
818	875	560	445	230	315	39	541	-	450	340	30	1090
820	980	625	500	260	355	42	599	-	500	380	30	1522
822	1100	700	615	300	400	45	675	-	560	438	35	2126
824	1240	790	675	320	450	48	761	-	630	490	40	2971

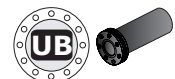
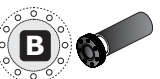
	Albero entrata / Input shaft / Antriebswelle			Albero uscita / Output shaft / Abtriebswelle								
	ECE 			N 			C 		UB 		B 	
	U	S	G	T m6	R	M	T H7	M1	T H7	M1	M3	
802	28 j6	50	350	60	112	109	60	109	60	109	170	
804	32 k6	56	390	70	125	121	70	121	70	121	192	
806	35 k6	63	440	80	140	137	80	137	80	137	215	
808	40 k6	70	495	90	160	151	90	151	90	151	246	
810	45 k6	80	555	100	180	170	100	170	100	170	266	
812	50 m6	90	625	110	200	192	110	192	110	192	302	
814	55 m6	100	700	125	225	216	125	216	125	216	335	
816	60 m6	112	780	140	250	242	140	242	140	242	370	
818	70 m6	125	880	160	280	273	160	273	160	273	422	
820	80 m6	140	990	180	315	302	180	302	180	302	477	
822	90 m6	160	1110	200	355	340	200	340	200	340	570	
824	100 m6	180	1250	220	400	383	220	383	220	383	617	

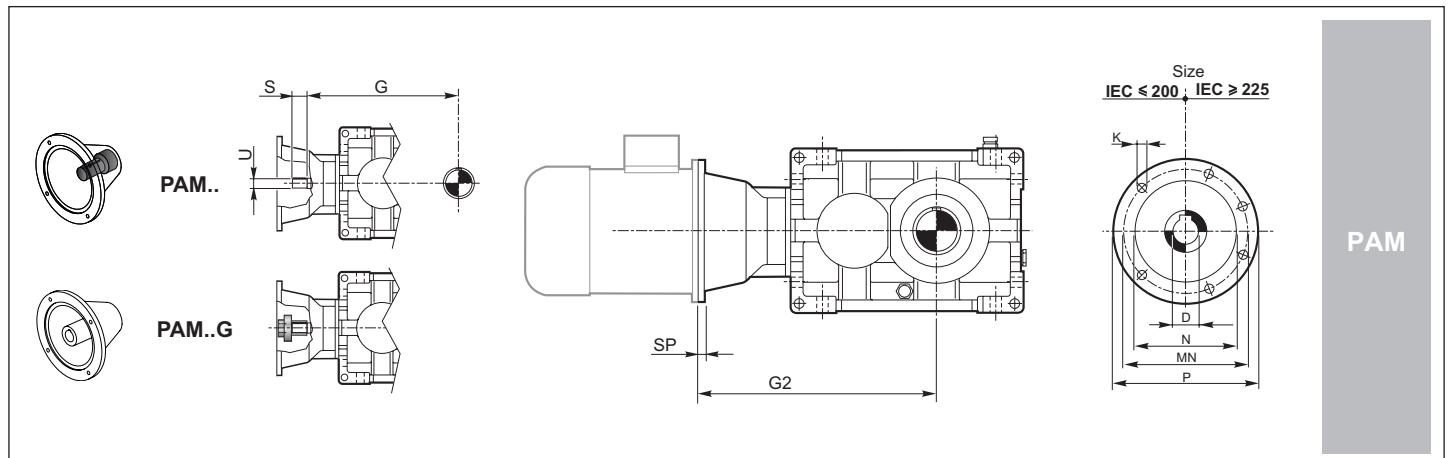

	IEC													
	71	80	90	100	112	132	160	180	200	225	250	280	315	355
D H7	14	19	24	28	28	38	42	48	55	60	65	75	80	100
P	160	200	200	250	250	300	350	350	400	450	550	550	660	800
MN	130	165	165	215	215	265	300	300	350	400	500	500	600	740
N G6	110	130	130	180	180	230	250	250	300	350	450	450	550	680
K	M8	M10	M10	M12	M12	M12	M16	M16	M16	M16	M16	M16	M20	M20
SP	12	12	12	14	14	16	18	18	20	20	20	20	24	30
G2	802			464	464	484	514	514	514					
	804					530	560	560	560	590				
	806					587	617	617	617	647				
	808						679	679	679	709	709	709		
	810							749	749	779	779	779	809	
	812							829	829	859	859	859	889	
	814									944	944	944	974	1014
	816									1036	1036	1036	1066	1106
	818										1149	1149	1179	1219
	820											1274	1304	1344

A richiesta / On request / Auf Anfrage

1.11 Dimensioni
Materiale Carcassa - "Ghisa"

1.11 Dimensions
Housing Material - "Cast Iron"

1.11 Abmessungen
Gehäusematerial - "Guss"

802-820

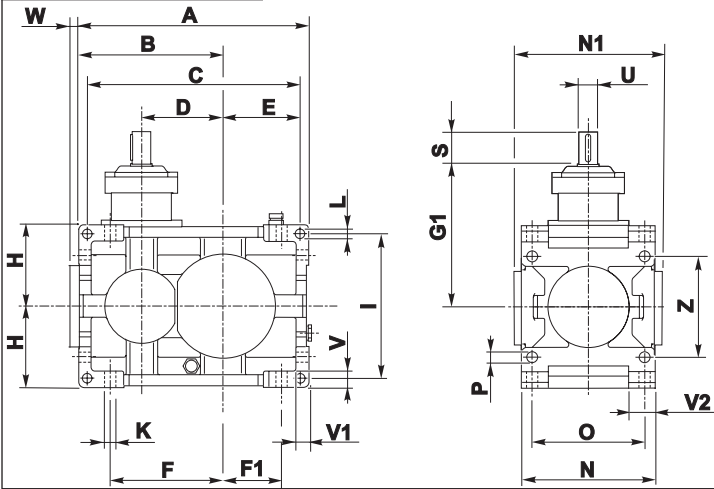

822-824

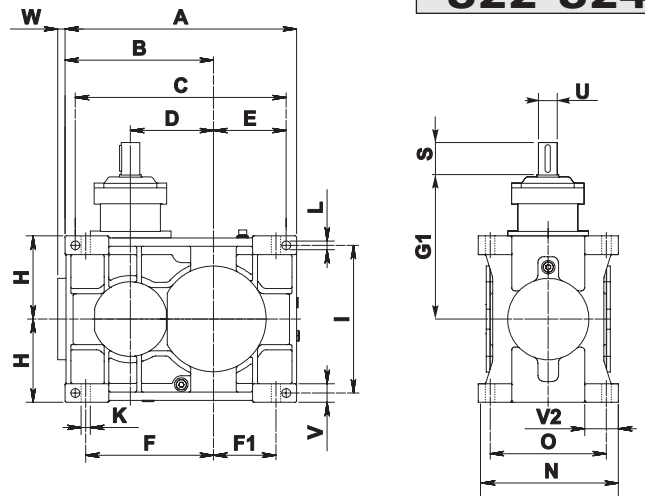

Esecuzione grafica / Shaft arrangement / Grafische Ausführung

Albero uscita / Output shaft / Abtriebswelle

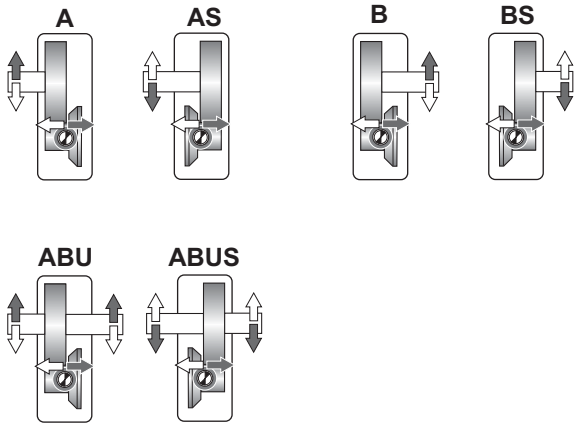

⇒ **N D FD Fn**

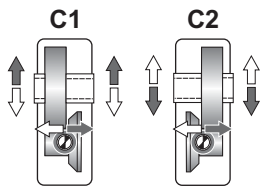
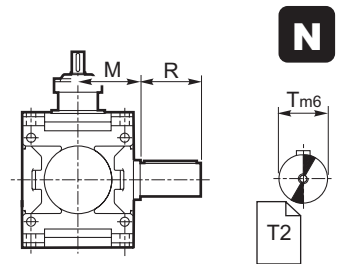

⇒ **C**

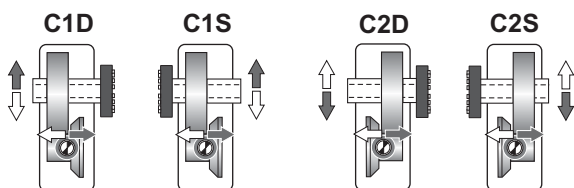
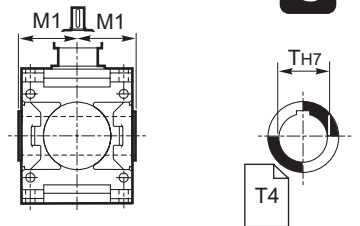

⇒ **UB B CD**

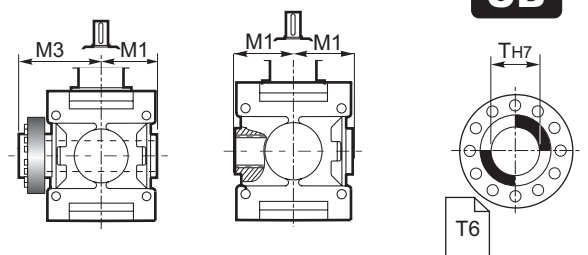





1.11 Dimensioni
Materiale Carcassa - "Ghisa"

1.11 Dimensions
Housing Material - "Cast Iron"

1.11 Abmessungen
Gehäusematerial - "Guss"

RX 800	Dimensioni generali / Dimensions / Allgemeine Abmessungen																			Kg	
	A	B	C	D	E	F	F1	H h11	I	K	L	N h11	N1	O	P	V	V1	V2	W		Z
802	355	225	327	125	116	175	90	125	224	18	14	213	219	180	18	25	20	44.5	17	160	82
804	402	252	370	140	134	196	104	140	250	20	16	237	241	200	20	28	22.5	49	18	180	114
806	455	285	421	160	153	222	117	160	280	22	18	269	271	225	22	32	25	56.5	20	200	154
808	510	320	472	180	171	250	130	180	320	25	20	297	299	250	25	36	28	59.5	21	224	211
810	570	360	530	200	190	280	145	200	360	27	22	335	327	280	27	40	32	67.5	24	250	292
812	645	405	600	225	217.5	315	160	225	400	30	24	379	380	315	30	45	36	78.5	28	280	387
814	715	450	665	250	240	350	180	250	450	33	27	427	424	355	33	50	40	89	29	320	561
816	805	505	749	280	272	393	203	280	500	36	30	479	473	400	36	56	45	96.5	30	360	782
818	910	570	846	320	308	445	230	315	560	39	35	541	497	450	39	63	50	114.5	33	400	1090
820	1020	640	948	360	344	500	260	355	638	42	39	599	550	500	42	70	56	124	36	450	1522
822	1115	715	1015	400	350	615	300	400	710	45	42	675	—	560	—	90	—	163	39	—	2126
824	1255	805	1145	450	395	675	320	450	800	48	45	761	—	630	—	100	—	176	42	—	2971

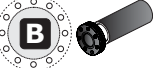
	Albero entrata / Input shaft / Antriebswelle			Albero uscita / Output shaft / Abtriebswelle								
	ECE 			N 			G 		UB 		B 	
	U	S	G1	T m6	R	M	T H7	M1	T H7	M1	M3	
802	28 j6	50	225	60	112	109	60	109	60	109	170	
804	32 k6	56	250	70	125	121	70	121	70	121	192	
806	35 k6	63	280	80	140	137	80	137	80	137	215	
808	40 k6	70	315	90	160	151	90	151	90	151	246	
810	45 k6	80	355	100	180	170	100	170	100	170	266	
812	50 m6	90	400	110	200	192	110	192	110	192	302	
814	55 m6	100	450	125	225	216	125	216	125	216	335	
816	60 m6	112	500	140	250	242	140	242	140	242	370	
818	70 m6	125	560	160	280	273	160	273	160	273	422	
820	80 m6	140	630	180	315	302	180	302	180	302	477	
822	90 m6	160	710	200	355	340	200	340	200	340	570	
824	100 m6	180	800	220	400	383	220	383	220	383	617	

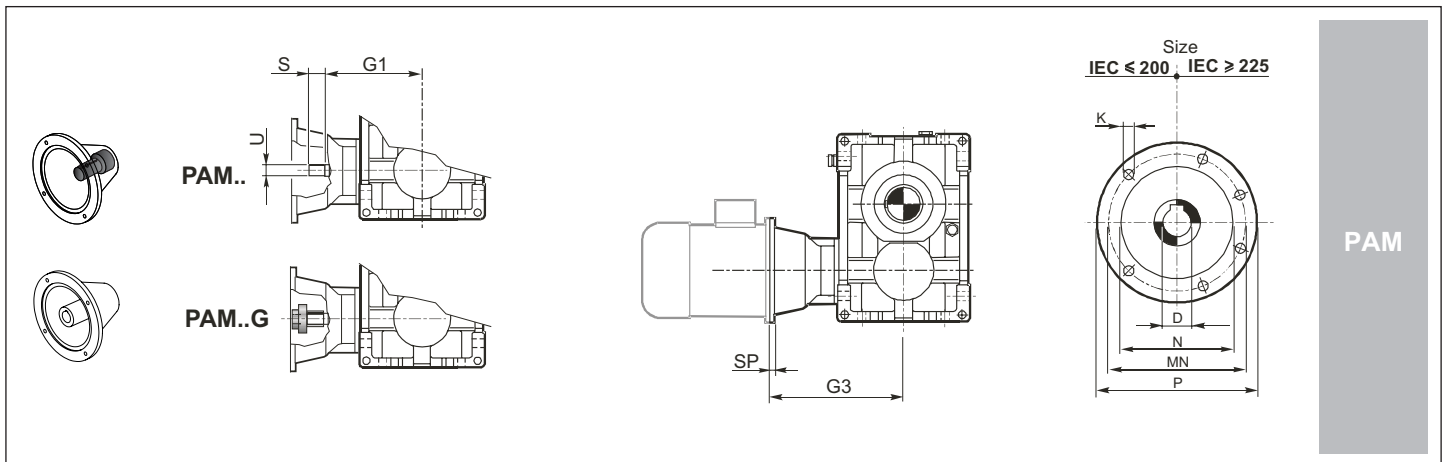

	IEC													
	71	80	90	100	112	132	160	180	200	225	250	280	315	355
D H7	14	19	24	28	28	38	42	48	55	60	65	75	80	100
P	160	200	200	250	250	300	350	350	400	450	550	550	660	800
MN	130	165	165	215	215	265	300	300	350	400	500	500	600	740
N G6	110	130	130	180	180	230	250	250	300	350	450	450	550	680
K	M8	M10	M10	M12	M12	M12	M16	M16	M16	M16	M16	M16	M20	M20
SP	12	12	12	14	14	16	18	18	20	20	20	20	24	30
G3	802			339	339	359	389	389	389					
	804					390	420	420	420	450				
	806					427	457	457	457	487				
	808						499	499	499	529	529	529		
	810							549	549	579	579	579	609	
	812							604	604	634	634	634	664	
	814									694	694	694	724	764
	816									756	756	756	786	826
	818										829	829	859	899
	820											914	944	984

A richiesta / On request / Auf Anfrage

1.11 Dimensioni
Materiale Carcassa - "Acciaio"

1.11 Dimensions
Housing Material - "Steel"

1.11 Abmessungen
Gehäusematerial - "Stahl"

802-814

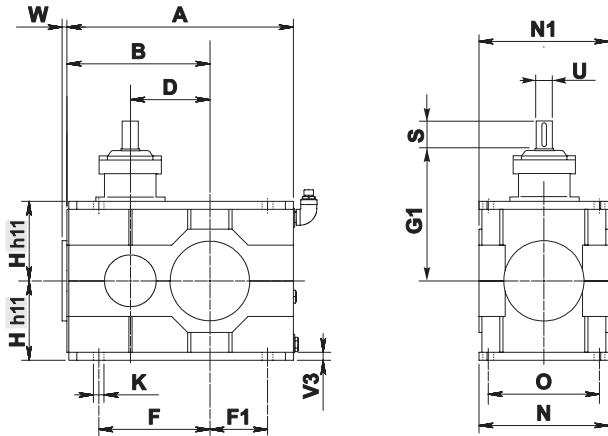

816-824

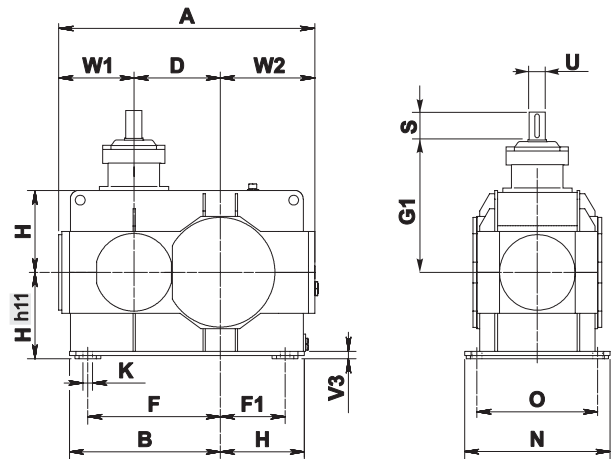

Esecuzione grafica / Shaft arrangement / Grafische Ausführung

Albero uscita / Output shaft / Abtriebswelle

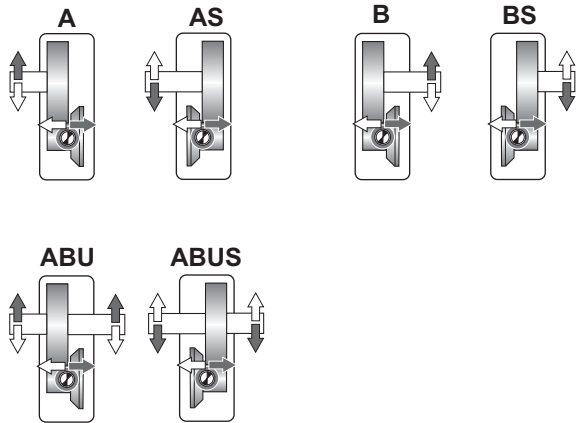

⇒ **N D FD Fn**

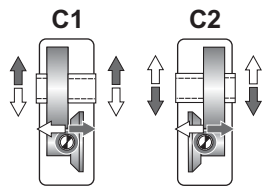
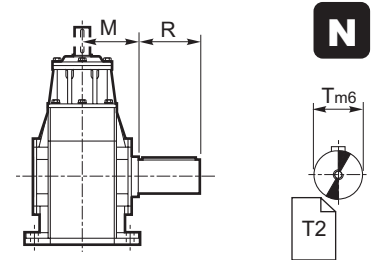

⇒ **C**

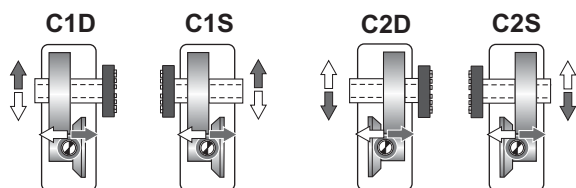
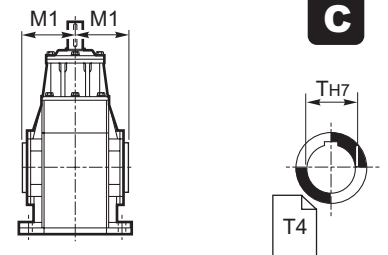

⇒ **UB B CD**

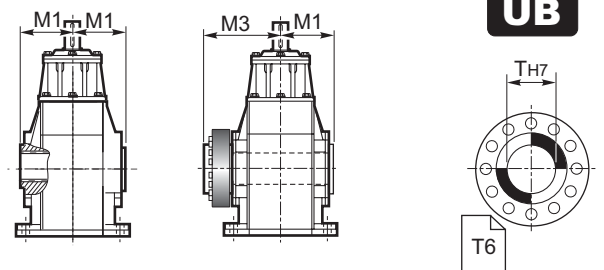





1.11 Dimensioni
Materiale Carcassa - "Acciaio"

1.11 Dimensions
Housing Material - "Steel"

1.11 Abmessungen
Gehäusematerial - "Stahl"

RX 800	Dimensioni generali / Dimensions / Allgemeine Abmessungen														
	A	B	D	F	F1	H	K	N	N1	O	W	W1	W2	V3	kg
802	355	225	125	175	90	125	18	213	218	180	17	-	-	10	82
804	402	252	140	196	104	140	20	237	241	200	18	-	-	12	114
806	455	285	160	222	117	160	22	269	266	225	20	-	-	15	154
808	510	320	180	250	130	180	25	297	299	250	21	-	-	15	211
810	570	360	200	280	145	200	27	327	327	280	24	-	-	20	292
812	605	405	225	315	160	225	30	380	376	315	28	-	-	20	387
814	715	450	250	350	180	250	33	427	420	355	29	-	-	20	561
816	775	495	280	393	203	280	36	480	-	400	-	255	305	30	782
818	875	560	320	445	230	315	39	541	-	450	-	290	340	30	1090
820	980	625	360	500	260	355	42	599	-	500	-	320	380	30	1522
822	1100	700	400	615	300	400	45	675	-	560	-	370	438	35	2126
824	1240	790	450	675	320	450	48	761	-	630	-	400	490	40	2971

	Albero entrata / Input shaft / Antriebswelle			Albero uscita / Output shaft / Abtriebswelle								
	ECE 			N 			C 		UB 		B 	
	U	S	G1	T m6	R	M	T H7	M1	T H7	M1	M3	
802	28 j6	50	225	60	112	109	60	109	60	109	170	
804	32 k6	56	250	70	125	121	70	121	70	121	192	
806	35 k6	63	280	80	140	137	80	137	80	137	215	
808	40 k6	70	315	90	160	151	90	151	90	151	246	
810	45 k6	80	355	100	180	170	100	170	100	170	266	
812	50 m6	90	400	110	200	192	110	192	110	192	302	
814	55 m6	100	450	125	225	216	125	216	125	216	335	
816	60 m6	112	500	140	250	242	140	242	140	242	370	
818	70 m6	125	560	160	280	273	160	273	160	273	422	
820	80 m6	140	630	180	315	302	180	302	180	302	477	
822	90 m6	160	710	200	355	340	200	340	200	340	570	
824	100 m6	180	800	220	400	383	220	383	220	383	617	

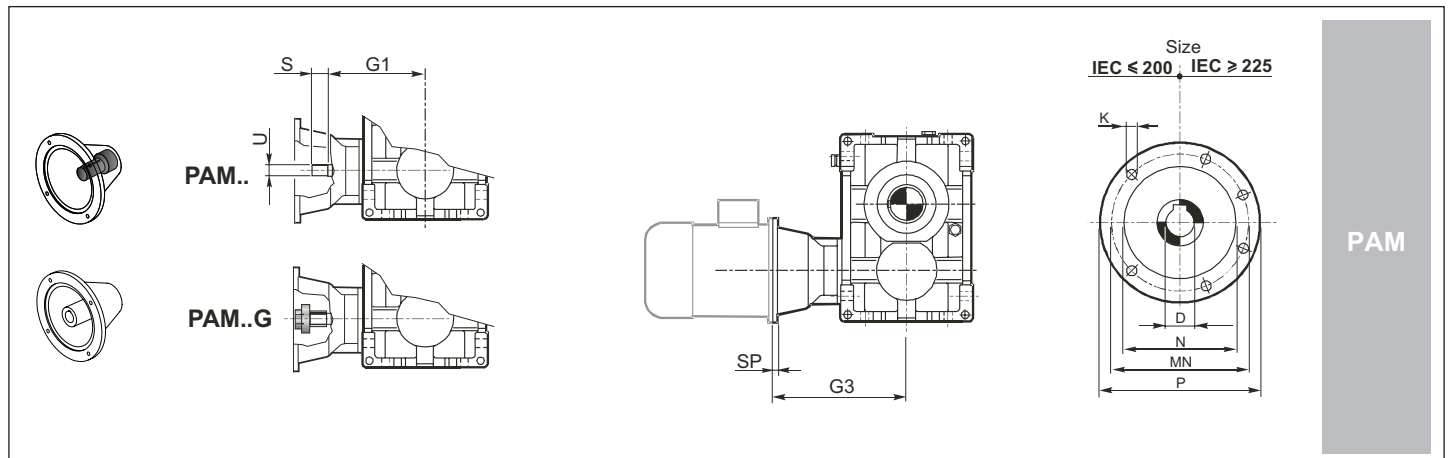

	IEC													
	71	80	90	100	112	132	160	180	200	225	250	280	315	355
D H7	14	19	24	28	28	38	42	48	55	60	65	75	80	100
P	160	200	200	250	250	300	350	350	400	450	550	550	660	800
MN	130	165	165	215	215	265	300	300	350	400	500	500	600	740
N G6	110	130	130	180	180	230	250	250	300	350	450	450	550	680
K	M8	M10	M10	M12	M12	M12	M16	M16	M16	M16	M16	M16	M20	M20
SP	12	12	12	14	14	16	18	18	20	20	20	20	24	30
G3	802			339	339	359	389	389	389					
	804						390	420	420	450				
	806						427	457	457	487				
	808						499	499	499	529	529	529		
	810							549	549	579	579	579	609	
	812							604	604	634	634	634	664	
	814									694	694	694	724	764
	816									756	756	756	786	826
	818									829	829	829	859	899
820											914	944	984	
822-824														

A richiesta / On request / Auf Anfrage

708-712-716-720

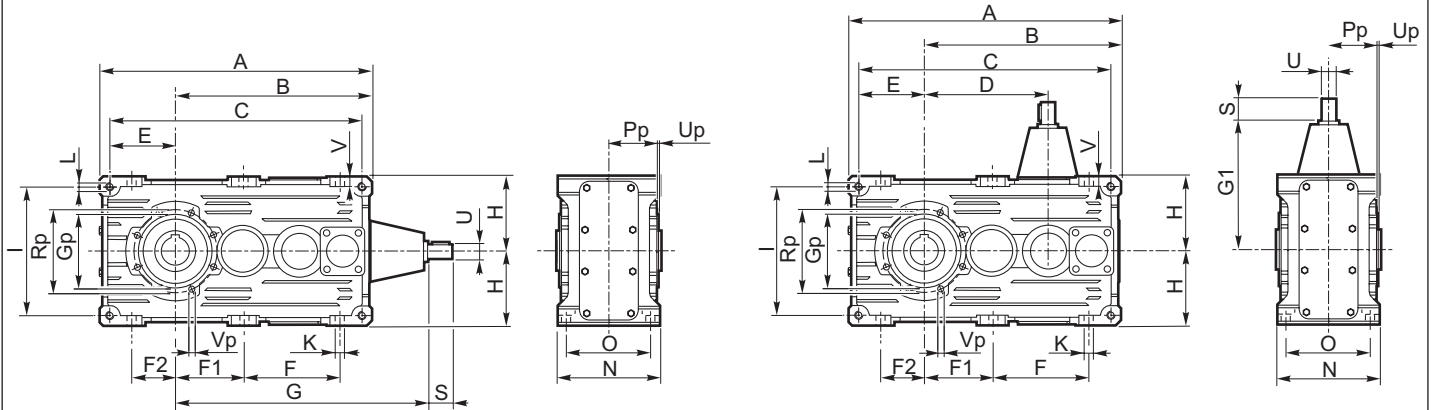

Esecuzione grafica / Shaft arrangement / Grafische Ausführung

Albero uscita / Output shaft / Abtriebswelle

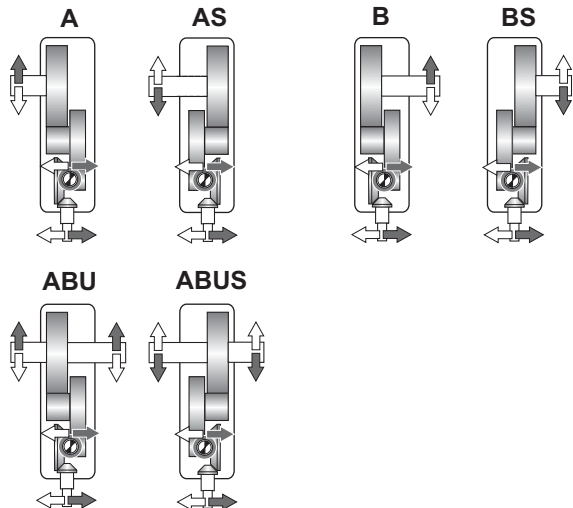

⇒ **N D FD**

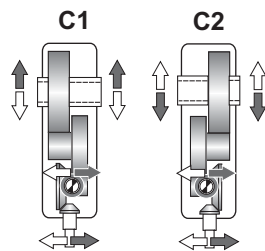
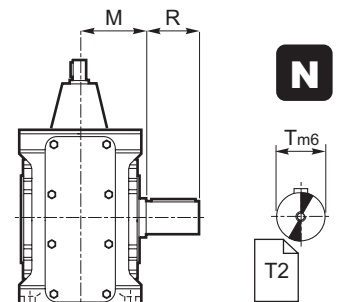

⇒ **G**

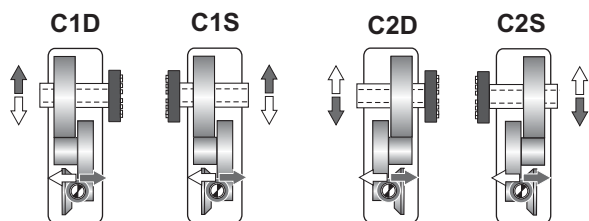
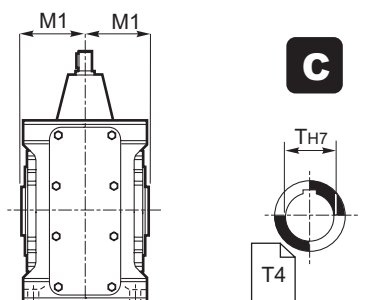

⇒ **UB B CD**

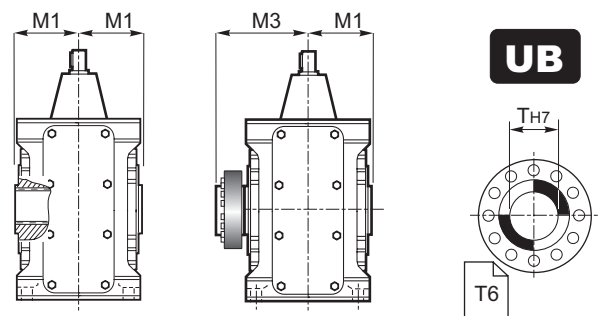

1.11 Dimensioni

1.11 Dimensions

1.11 Abmessungen

RX 700	Dimensioni generali / Dimensions / Allgemeine Abmessungen																				kg ECE	kg PAM
	A	B	C	D	E	F	F1	F2	H _{h11}	I	K	L	N _{h11}	O	V	Gp	Pp	Rp	Up	Vp		
708	306	226	281	141	67.5	106	82	42	80	135	11	M10	127	104	12	90	58.5	105	3	8	19	22
712	384	284	354	180	85	134	102	52	100	170	13	M12	150	125	15	110	70.5	125	3	8	36	41
716	479	354	443	227	107	169	127	67	125	214	15	M14	175	145	16	130	81	150	3	10	66	76
720	609.5	449.5	569.5	285	140	217	162.5	90	160	280	17	M16	215	180	17	170	103.5	200	4	M12	124	131

ECE	Albero entrata / Input shaft / Antriebswelle				Albero uscita / Output shaft / Abtriebswelle								
	U	S	G	G1	T	R	M	T H7	M1	T H7	M1	M3	
708	14 j6	30	251	110	32 k6	60	71	32 (30) (35)	65	35	65	95	
712	19 j6	40	310	130	42 k6	80	85.5	42 (40) (45)	77.5	45	77.5	112.5	
716	24 j6	50	387	160	55 k6	100	100	55 (50)	90	55	90	125	
720	28 j6	60	475	190	70 m6	125	122	70 (60)	110	70	110	154	

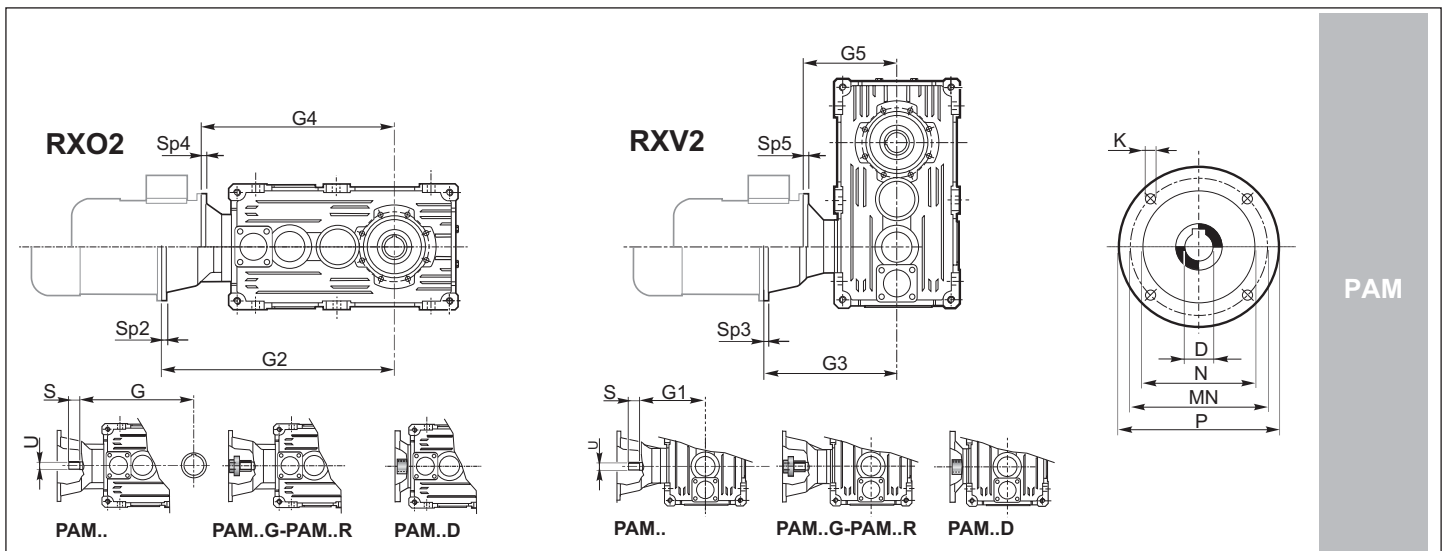

	IEC																			
	63		71		80		90		100		112		132		160		180		200	
	B5	B5	B5	B14	B5	B14	B5	B14	B5	B14	B5	B14	B5	B14	B5	B5	B5	B5	B5	B5
D H7	11	14	19	19	24	24	28	28	28	28	38	38	42	48	55					
P	140	160	200	120	200	140	250	160	250	160	300	200	350	350	400					
MN	115	130	165	100	165	115	215	130	215	130	265	165	300	300	350					
N G6	95	110	130	80	130	95	180	110	180	110	230	130	250	250	300					
K	M8	M8	M10	M6	M10	M8	M12	M8	M12	M8	M12	M10	M16	M16	M16					
SP2/SP3/SP4/SP5	A richiesta / On request / Auf Anfrage																			

RX02	708	PAM...G-R	G2	308	315	336	—	336	—														
		PAM..D	G4	281	281	281	281	281	281														
		PAM..D	G4		344	344	344	344	344	344	344	344	344										
	712	PAM...G-R	G2		384	405	—	405	—	415	—	415	—										
		PAM..D	G4		344	344	344	344	344	344	344	344	344										
	716	PAM...G-R	G2			492	—	492	—	502	—	502	—	522	—								
PAM..D		G4			438	—	438	—	438	—	438	—	438	438									
720	PAM...	G2							600	—	600	—	—	—	—	—	—	—	—	—	—	—	
	PAM...G-R	G2								—	600	—	554*	—	563*	563*							
	PAM..D	G4			520	—	520	—	520	—	520	—	520	520	—	—	—	—	—	—	—	—	
RXV2	708	PAM...G-R	G3	167	174	195	—	195	—														
		PAM..D	G5	140	140	140	140	140	140														
		PAM..D	G5		164	164	164	164	164	164	164	164	164										
	712	PAM...G-R	G3		204	225	—	225	—	235	—	235	—										
		PAM..D	G5		164	164	164	164	164	164	164	164	164										
	716	PAM...G-R	G3			265	—	265	—	275	—	275	—	295	—								
		PAM..D	G5			211	—	211	—	211	—	211	—	211	211								
	720	PAM...	G3							315	—	315	—	—	—	—	—	—	—	—	—	—	—
		PAM...G-R	G3								—	315	—	269*	—	278*	278*						
PAM..D		G5			235	—	235	—	235	—	235	—	235	235	—	—	—	—	—	—	—	—	

* Solo PAM...G - forniti con giunto tipo Rotex.

* Only PAM...G - come with Rotex coupling.

* nur PAM...G - Werden sie mit Kupplung Typ Rotex geliefert.

1.11 Dimensioni
Materiale Carcassa - "Ghisa"

1.11 Dimensions
Housing Material - "Cast Iron"

1.11 Abmessungen
Gehäusematerial - "Guss"

802-820

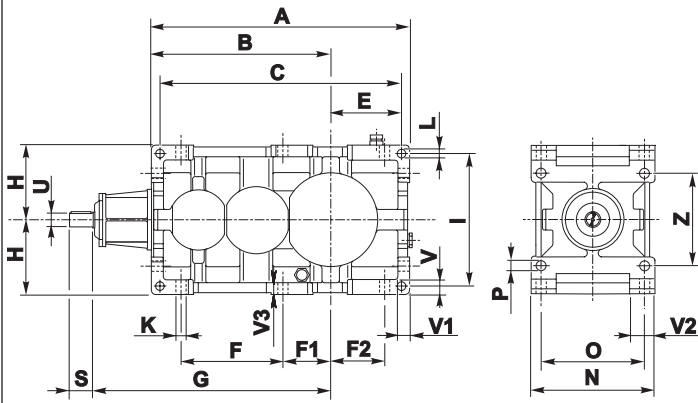

822-826

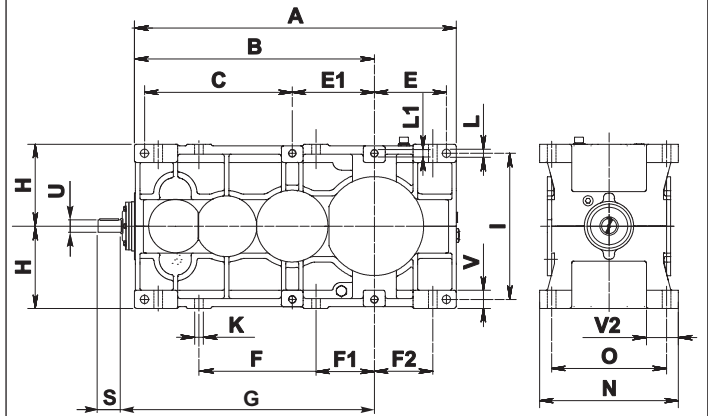

Esecuzione grafica / Shaft arrangement / Grafische Ausführung

Albero uscita / Output shaft / Abtriebswelle

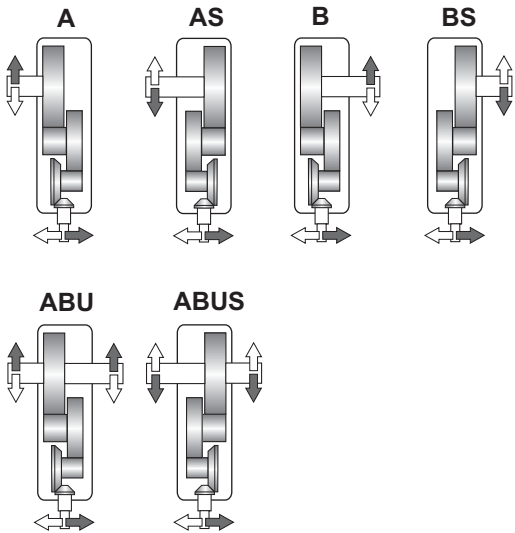

⇒ **N D FD Fn**

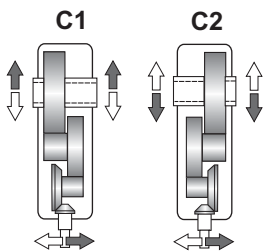
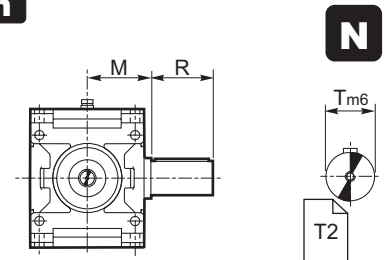

⇒ **C**

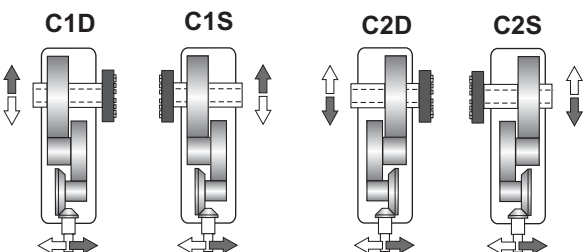
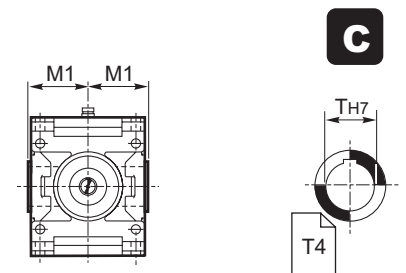

⇒ **UB B CD**

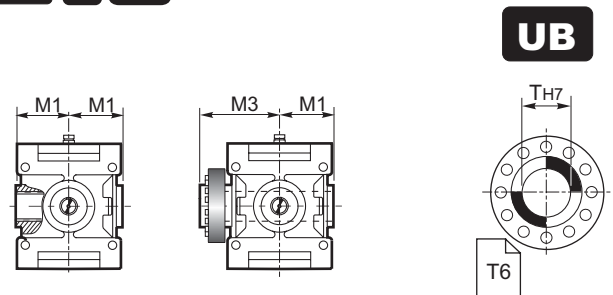





1.11 Dimensioni
Materiale Carcassa - "Ghisa"

1.11 Dimensions
Housing Material - "Cast Iron"

1.11 Abmessungen
Gehäusematerial - "Guss"

RX 800	Dimensioni generali / Dimensions / Allgemeine Abmessungen																					
	A	B	C	E	E1	F	F1	F2	H _{h11}	I	K	L	L1	N _{h11}	O	P	V	V1	V2	V3	Z	Kg
802	435	305	407	116	—	172.5	82.5	90	125	224	18	14	—	213	180	18	25	20	44.5	19	160	98
804	492	342	460	134	—	195	91	104	140	250	20	16	—	237	200	20	28	22.5	49	23	180	131
806	555	385	521	153	—	219.5	102.5	117	160	280	22	18	—	269	225	22	32	25	56.5	25	200	183
808	622	432	584	171	—	246	116	130	180	320	25	20	—	297	250	25	36	28	59.5	28	224	247
810	695	485	655	190	—	275	130	145	200	360	27	22	—	335	280	27	40	32	67.5	32	250	352
812	785	545	740	217.5	—	307.5	147.5	160	225	400	30	24	—	379	315	30	45	36	78.5	36	280	477
814	875	610	825	240	—	345	165	180	250	450	33	27	—	427	355	33	50	40	89	40	320	659
816	985	685	929	272	—	388	185	203	280	500	36	30	—	479	400	36	56	45	96.5	45	360	917
818	1110	770	1046	308	—	437.5	207.5	230	315	560	39	35	—	541	450	39	63	50	114.5	48	400	1281
820	1245	865	1173	344	—	492.5	232.5	260	355	638	42	39	—	599	500	42	70	56	124	56	450	1789
822	1570	1170	720	350	400	570	300	300	400	710	45	42	M39	675	560	-	90	-	162	50	-	2711
824	1765	1315	810	395	450	640	320	320	450	800	48	45	M42	761	630	-	100	-	175	55	-	3711
826	1970	1470	910	440	500	715	365	365	500	900	52	52	M45	855	710	-	100	-	197	55	-	4661

	Albero entrata / Input shaft / Antriebswelle			Albero uscita / Output shaft / Abtriebswelle											
	ECE 			N 			C 			UB 			B 		
	U	S	G	T m6	R	M	T H7	M1		T H7	M1	M3			
802	22 j6	40	405	60	112	109	60	109		60	109	170			
804	24 j6	45	452	70	125	121	70	121		70	121	192			
806	28 j6	50	510	80	140	137	80	137		80	137	215			
808	32 k6	56	570	90	160	151	90	151		90	151	246			
810	35 k6	63	640	100	180	170	100	170		100	170	266			
812	40 k6	70	720	110	200	192	110	192		110	192	302			
814	45 k6	80	805	125	225	216	125	216		125	216	335			
816	50 k6	90	905	140	250	242	140	242		140	242	370			
818	55 m6	100	1020	160	280	273	160	273		160	273	422			
820	60 m6	112	1140	180	315	302	180	302		180	302	477			
822	70 m6	125	1280	200	355	340	200	340		200	340	570			
824	80 m6	140	1440	220	400	383	220	383		220	383	617			
826	90 m6	160	1610	250	450	430	250	430		250	430	685			

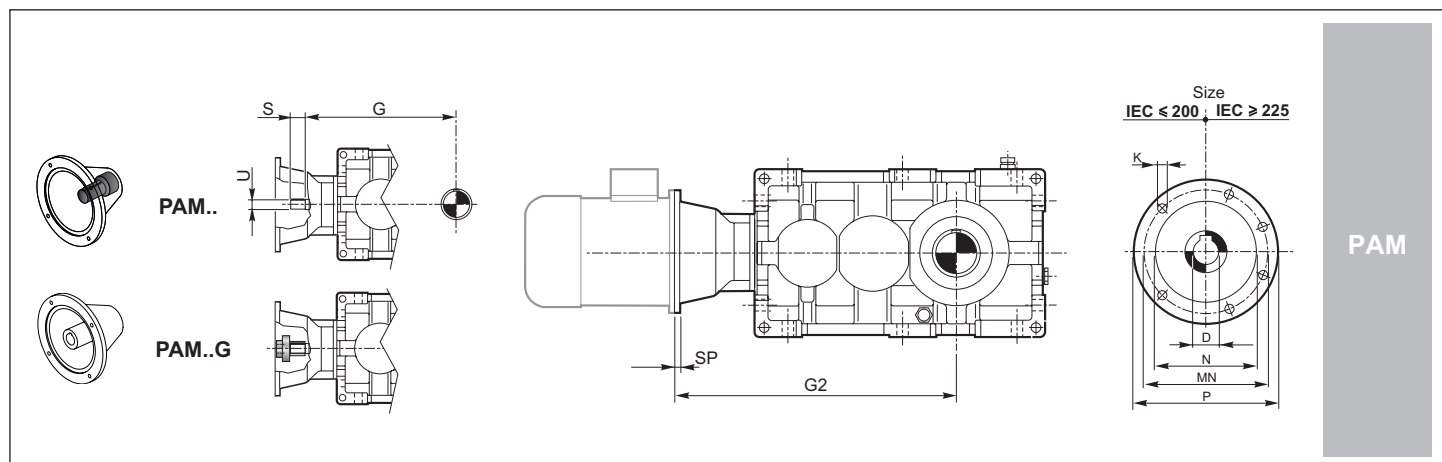

		IEC														
		71	80	90	100	112	132	160	180	200	225	250	280	315	355	
D H7		14	19	24	28	28	38	42	48	55	60	65	75	80	100	
P		160	200	200	250	250	300	350	350	400	450	550	550	660	800	
MN		130	165	165	215	215	265	300	300	350	400	500	500	600	740	
N G6		110	130	130	180	180	230	250	250	300	350	450	450	550	680	
K		M8	M10	M10	M12	M12	M12	M16	M16	M16	M16	M16	M16	M20	M20	
SP		12	12	12	14	14	16	18	18	20	20	20	20	24	30	
G2	802			499	509	509	529	559	559	559						
	804				561	561	581	611	611	611	641					
	806				624	624	644	674	674	674	704					
	808						710	740	740	740	770	770	770			
	810						787	817	817	817	847	847	847	877		
	812						874	904	904	904	934	934	934	964		
	814							999	999	999	1029	1029	1029	1059		
	816							1109	1109	1109	1139	1139	1139	1169	1209	
	818										1234	1264	1264	1264	1294	1334
	820										1396	1396	1396	1426	1466	
822-826																

A richiesta / On request / Auf Anfrage

1.11 Dimensioni
Materiale Carcassa - "Acciaio"

1.11 Dimensions
Housing Material - "Steel"

1.11 Abmessungen
Gehäusematerial - "Stahl"

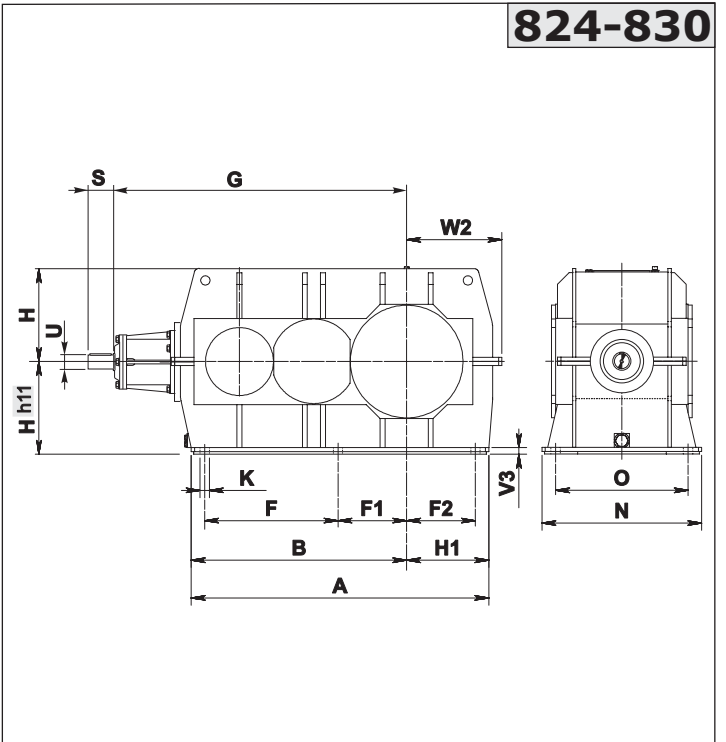
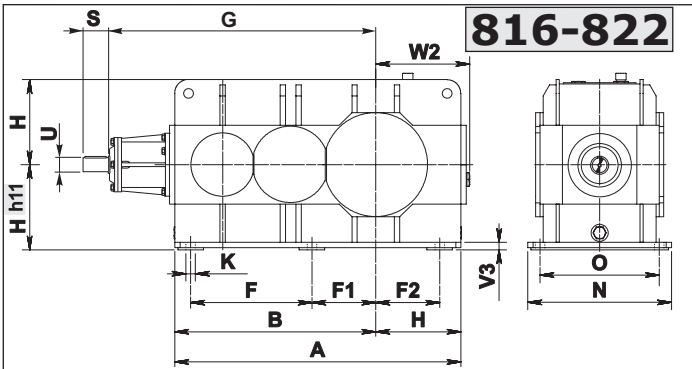
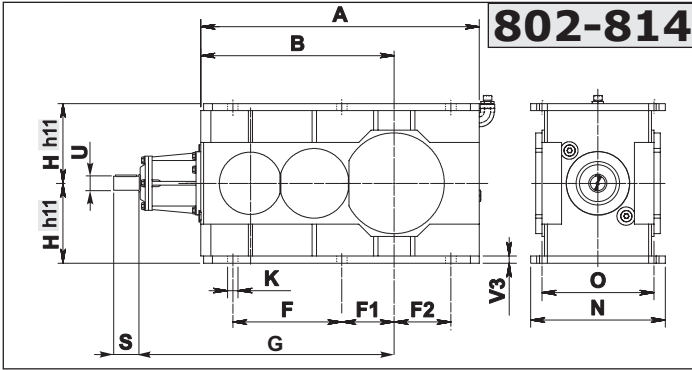

Esecuzione grafica / Shaft arrangement / Grafische Ausführung

Albero uscita / Output shaft / Abtriebswelle

→ **N D FD Fn**

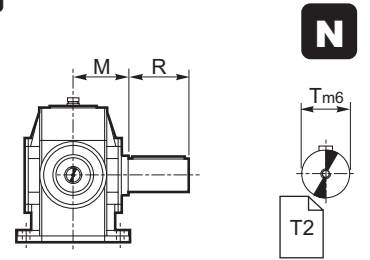
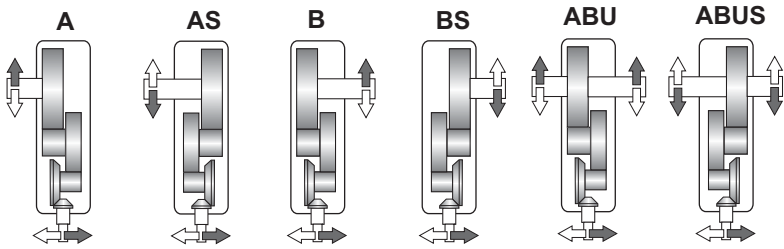

→ **G**

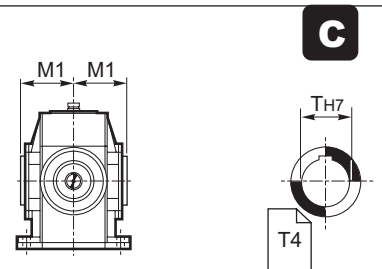
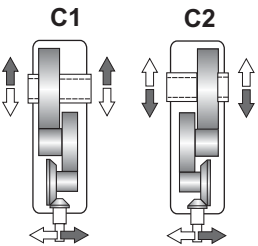

→ **UB B CD**

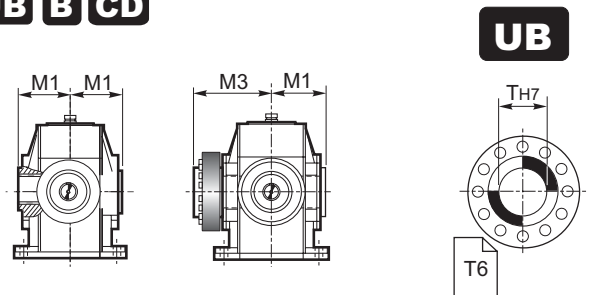
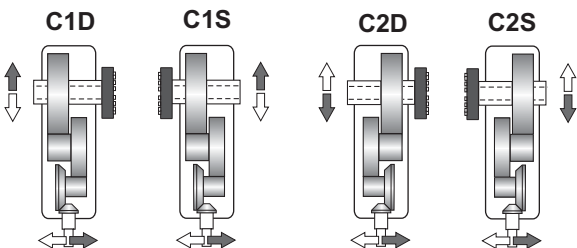





**1.11 Dimensioni
Materiale Carcassa - "Acciaio"**

**1.11 Dimensions
Housing Material - "Steel"**

**1.11 Abmessungen
Gehäusematerial - "Stahl"**

RX 800	Dimensioni generali / Dimensions / Allgemeine Abmessungen												
	A	B	F	F1	F2	H	H1	K	N	O	V3	W2	ka
802	435	305	172.5	82.5	90	125	-	18	213	180	10	-	98
804	492	342	195	91	104	140	-	20	237	200	12	-	131
806	555	385	219.5	102.5	117	160	-	22	269	225	15	-	183
808	632	432	246	116	130	180	-	25	297	250	15	-	247
810	695	485	275	130	145	200	-	27	335	280	20	-	352
812	785	545	307.5	147.5	160	225	-	30	379	315	20	-	477
814	875	610	345	165	180	250	-	33	427	355	20	-	659
816	950	670	388	185	203	280	-	36	479	400	30	321	917
818	1060	745	437.5	207.5	230	315	-	39	541	450	30	356	1281
820	1195	840	492.5	232.5	260	355	-	42	599	500	30	396	1789
822	1345	945	570	300	300	400	-	45	675	560	35	441	2499
824	1400	1020	640	320	320	450	380	48	761	630	35	480	2972
826	1575	1145	715	365	365	500	430	52	855	710	35	545	3911
828	1797	1301	805	415	415	560	496	56	965	800	40	575	6211
830	2050	1500	950	470	470	630	550	60	1080	900	45	665	9411

	Albero entrata / Input shaft / Antriebswelle			Albero uscita / Output shaft / Abtriebswelle								
	ECE 			N 			C 		UB 		B 	
	U	S	G	T m6	R	M	T H7	M1	T H7	M1	M3	
802	22 i6	40	405	60	112	109	60	109	60	109	170	
804	24 i6	45	452	70	125	121	70	121	70	121	192	
806	28 i6	50	510	80	140	137	80	137	80	137	215	
808	32 k6	56	570	90	160	151	90	151	90	151	246	
810	35 k6	63	640	100	180	170	100	170	100	170	266	
812	40 k6	70	720	110	200	192	110	192	110	192	302	
814	45 k6	80	805	125	225	216	125	216	125	216	335	
816	50 k6	90	905	140	250	242	140	242	140	242	370	
818	55 m6	100	1020	160	280	273	160	273	160	273	422	
820	60 m6	112	1140	180	315	302	180	302	180	302	477	
822	70 m6	125	1280	200	355	340	200	340	200	340	570	
824	80 m6	140	1440	220	400	383	220	383	220	383	617	
826	90 m6	160	1610	250	450	430	250	430	250	430	685	
828	100 m6	180	1810	280	500	485	280	485	280	485	765	
830	110 m6	200	2040	320	500	545	320	545	320	545	840	

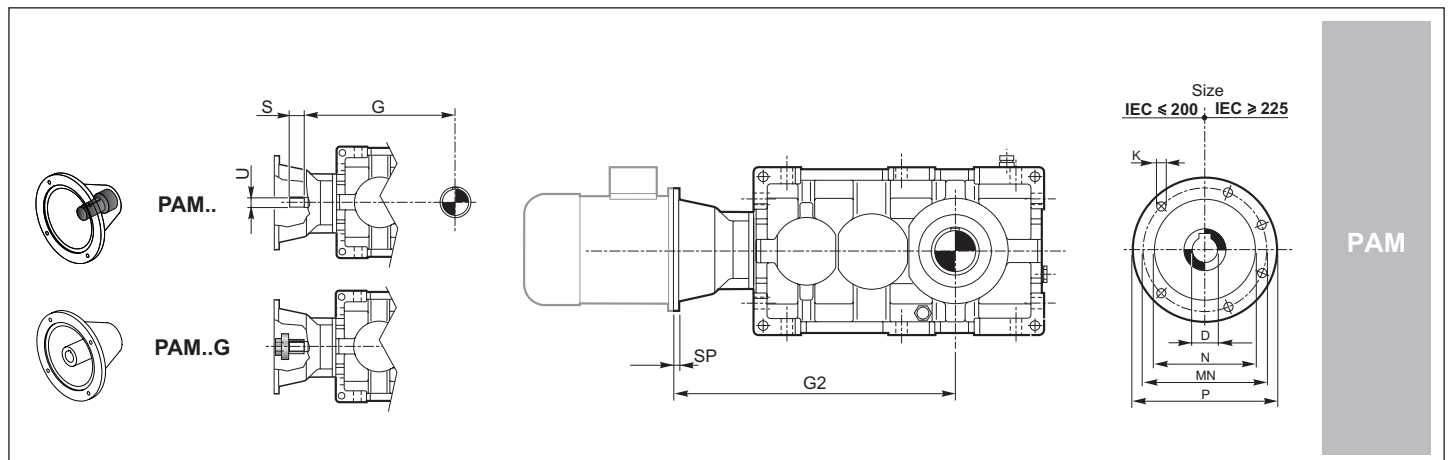

		IEC													
		71	80	90	100	112	132	160	180	200	225	250	280	315	355
D H7		14	19	24	28	28	38	42	48	55	60	65	75	80	100
P		160	200	200	250	250	300	350	350	400	450	550	550	660	800
MN		130	165	165	215	215	265	300	300	350	400	500	500	600	740
N G6		110	130	130	180	180	230	250	250	300	350	450	450	550	680
K		M8	M10	M10	M12	M12	M12	M16	M16	M16	M16	M16	M16	M20	M20
SP		12	12	12	14	14	16	18	18	20	20	20	20	24	30
G2	802			499	509	509	529	559	559	559					
	804				561	561	581	611	611	611	641				
	806				624	624	644	674	674	674	704				
	808						710	740	740	740	770	770	770		
	810						787	817	817	817	847	847	847	877	
	812						874	904	904	904	934	934	934	964	
	814							999	999	999	1029	1029	1029	1059	
	816							1109	1109	1109	1139	1139	1139	1169	1209
818										1234	1264	1264	1264	1294	1334
820											1396	1396	1396	1426	1466
822-830															

A richiesta / On request / Auf Anfrage

1.11 Dimensioni
Materiale Carcassa - "Ghisa"

1.11 Dimensions
Housing Material - "Cast Iron"

1.11 Abmessungen
Gehäusematerial - "Guss"

802-820

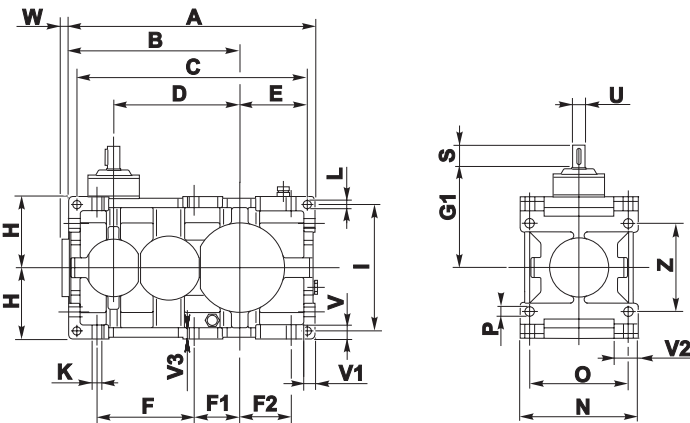

822-826

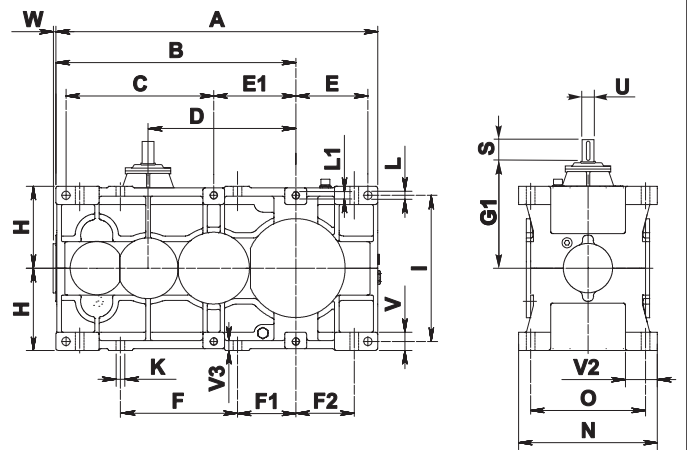

Esecuzione grafica / Shaft arrangement / Grafische Ausführung

Albero uscita / Output shaft / Abtriebswelle

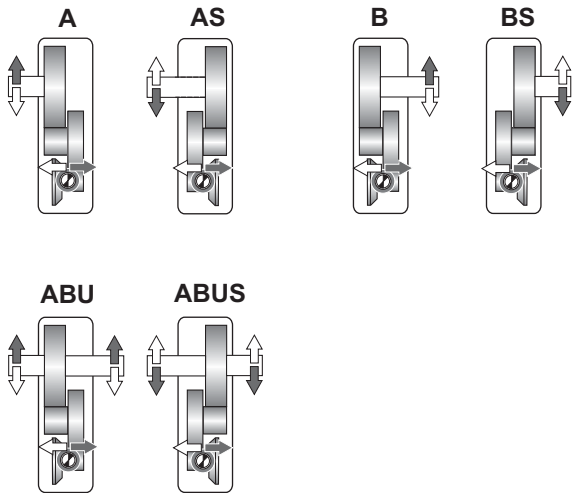

⇒ **N D FD Fn**

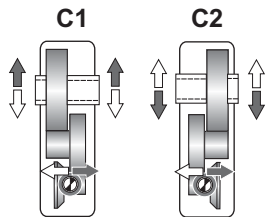
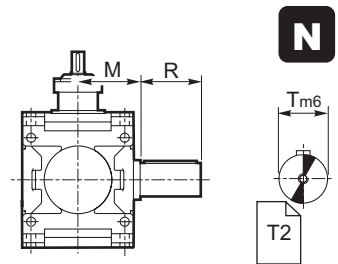

⇒ **C**

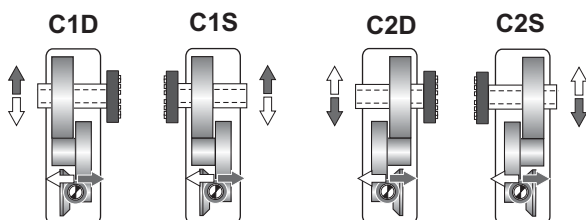
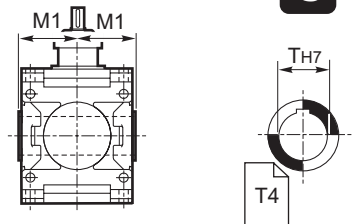

⇒ **UB B CD**

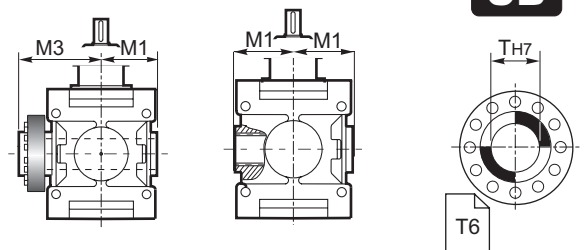

1.11 Dimensioni
Materiale Carcassa - "Ghisa"

1.11 Dimensions
Housing Material - "Cast Iron"

1.11 Abmessungen
Gehäusematerial - "Guss"

RX 800	Dimensioni generali / Dimensions / Allgemeine Abmessungen																						Kg	
	A	B	C	D	E	E1	F	F1	F2	H _{h11}	I	K	L	L1	N _{h11}	O	P	V	V1	V2	V3	W		Z
802	435	305	407	225	116	—	172.5	82.5	90	125	224	18	14	—	213	180	18	25	20	44.5	19	14	160	98
804	492	342	460	252	134	—	195	91	104	140	250	20	16	—	237	200	20	28	22.5	49	23	15	180	131
806	565	385	521	285	153	—	219.5	102.5	117	160	280	22	18	—	269	225	22	32	25	56.5	25	17	200	183
808	632	432	584	320	171	—	246	116	130	180	320	25	20	—	297	250	25	36	28	59.5	28	18	224	247
810	695	485	655	360	190	—	275	130	145	200	360	27	22	—	335	280	27	40	32	67.5	32	20	250	352
812	785	545	740	405	217.5	—	307.5	147.5	160	225	400	30	24	—	379	315	30	45	36	78.5	36	21	280	477
814	875	610	825	450	240	—	345	165	180	250	450	33	27	—	427	355	33	50	40	89	40	24	320	659
816	985	685	929	505	272	—	388	185	203	280	500	36	30	—	479	400	36	56	45	96.5	45	28	360	917
818	1110	770	1046	570	308	—	437.5	207.5	230	315	560	39	35	—	541	450	39	63	50	114.5	48	29	400	1281
820	1245	865	1173	640	344	—	492.5	232.5	260	355	638	42	39	—	599	500	42	70	56	124	56	30	450	1789
822	1570	1170	720	720	350	400	570	300	300	400	710	45	42	M39	675	560	-	90	-	162	50	29	-	2711
824	1765	1315	810	810	395	450	640	320	320	450	800	48	45	M42	761	630	-	100	-	175	55	30	-	3711
826	1970	1470	910	900	440	500	715	365	365	500	900	52	52	M45	855	710	-	100	-	197	55	33	-	4661

	Albero entrata / Input shaft / Antriebswelle						Albero uscita / Output shaft / Abtriebswelle								
	ECE			N			C			UB			B		
	U	S	G1	T _{m6}	R	M	T _{H7}	M1		T _{H7}	M1	M3			
802	22 i6	40	180	60	112	109	60	109	60	109	170				
804	24 i6	45	200	70	125	121	70	121	70	121	192				
806	28 i6	50	225	80	140	137	80	137	80	137	215				
808	32 k6	56	250	90	160	151	90	151	90	151	246				
810	35 k6	63	280	100	180	170	100	170	100	170	266				
812	40 k6	70	315	110	200	192	110	192	110	192	302				
814	45 k6	80	355	125	225	216	125	216	125	216	335				
816	50 k6	90	400	140	250	242	140	242	140	242	370				
818	55 m6	100	450	160	280	273	160	273	160	273	422				
820	60 m6	112	500	180	315	302	180	302	180	302	477				
822	70 m6	125	560	200	355	340	200	340	200	340	570				
824	80 m6	140	630	220	400	383	220	383	220	383	617				
826	90 m6	160	710	250	450	430	250	430	250	430	685				

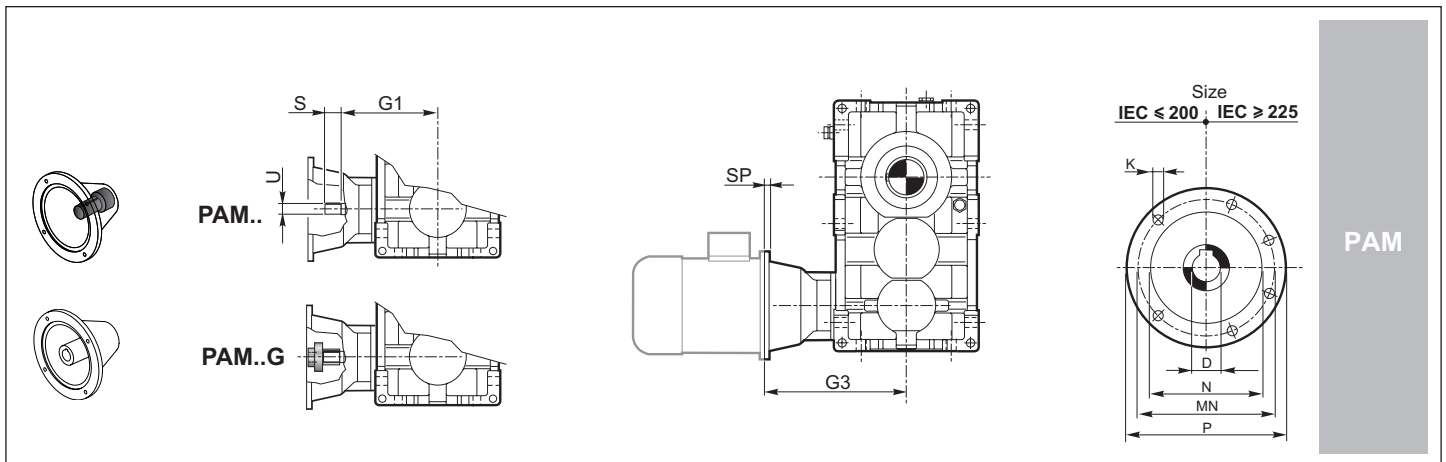

	IEC														
	71	80	90	100	112	132	160	180	200	225	250	280	315	355	
D H7	14	19	24	28	28	38	42	48	55	60	65	75	80	100	
P	160	200	200	250	250	300	350	350	400	450	550	550	660	800	
MN	130	165	165	215	215	265	300	300	350	400	500	500	600	740	
N G6	110	130	130	180	180	230	250	250	300	350	450	450	550	680	
K	M8	M10	M10	M12	M12	M12	M16	M16	M16	M16	M16	M16	M20	M20	
SP	12	12	12	14	14	16	18	18	20	20	20	20	24	30	
G3	802		274	284	284	304	334	334	334						
	804			309	309	329	359	359	359	389					
	806			339	339	359	389	389	389	419					
	808					390	420	420	420	450	450	450			
	810						427	457	457	457	487	487	487	517	
	812						469	499	499	499	529	529	529	559	
	814							549	549	549	579	579	579	609	
	816							604	604	604	634	634	634	664	704
	818								664	664	694	694	694	724	764
820									756	756	756	756	786	826	
822-826															

A richiesta / On request / Auf Anfrage

1.11 Dimensioni
Materiale Carcassa - "Acciaio"

1.11 Dimensions
Housing Material - "Steel"

1.11 Abmessungen
Gehäusematerial - "Stahl"

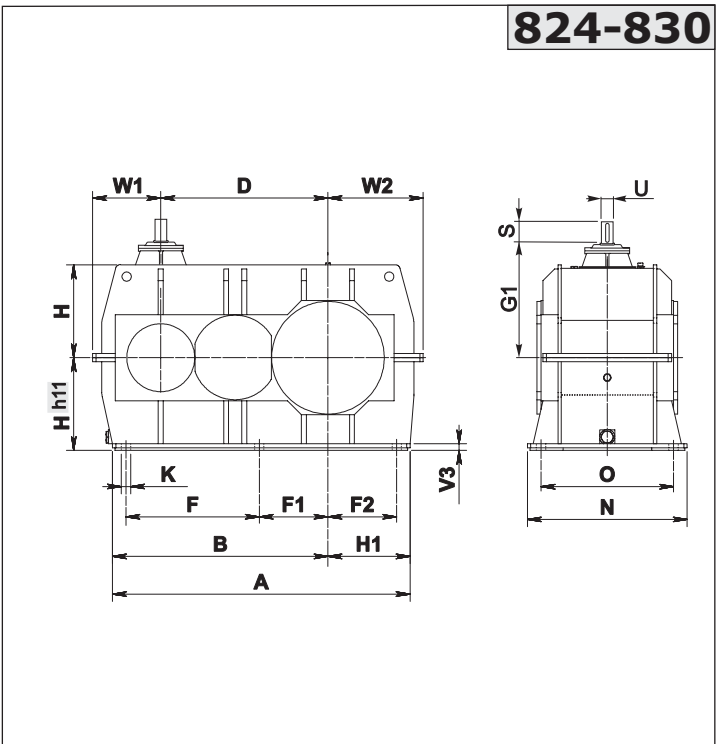
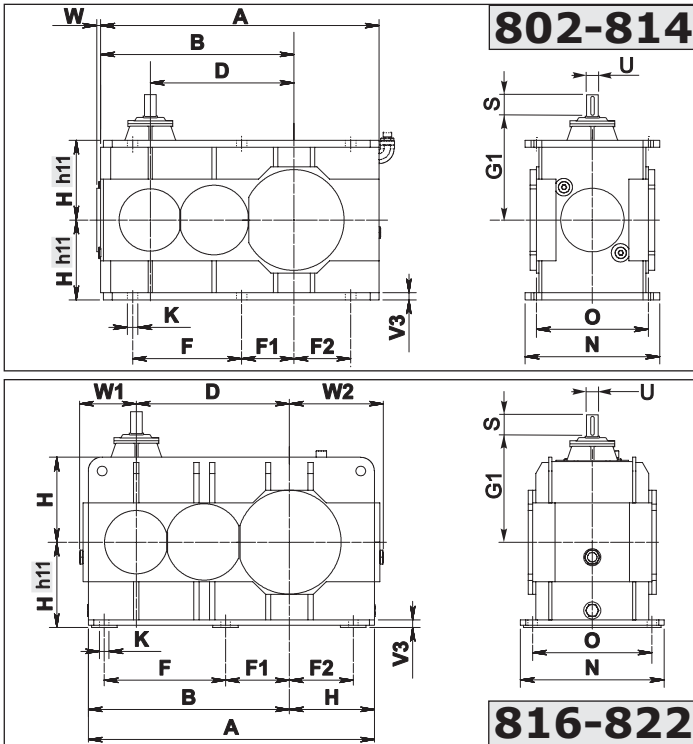

Esecuzione grafica / Shaft arrangement / Grafische Ausführung

Albero uscita / Output shaft / Abtriebswelle

→ **N D FD Fn**

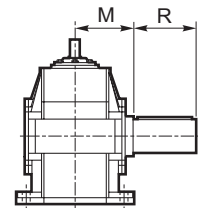
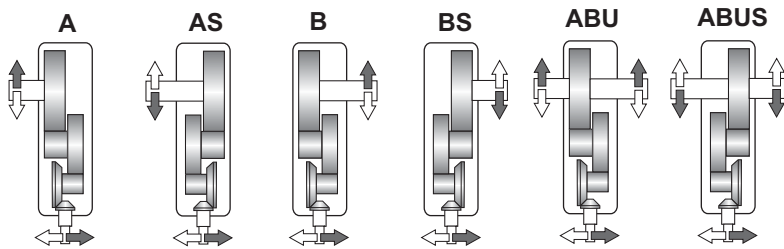

N

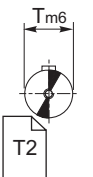

→ **G**

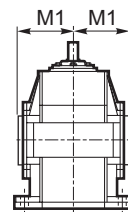
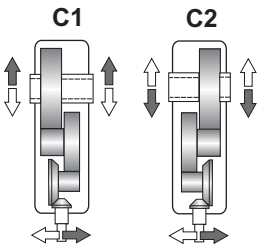

G

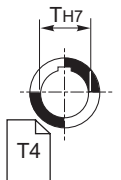

→ **UB B CD**

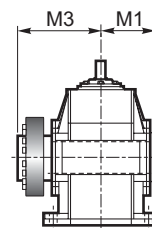
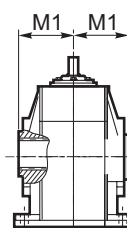
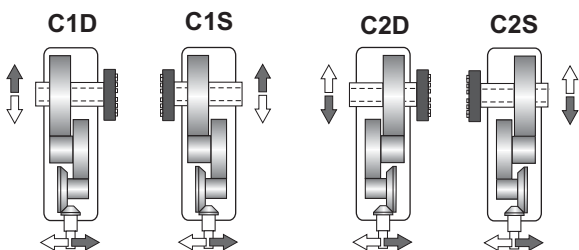

UB

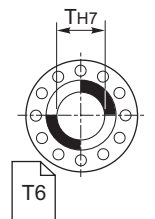





1.11 Dimensioni
Materiale Carcassa - "Acciaio"

1.11 Dimensions
Housing Material - "Steel"

1.11 Abmessungen
Gehäusematerial - "Stahl"

RX 800	Dimensioni generali / Dimensions / Allgemeine Abmessungen															
	A	B	D	F	F1	F2	H	H1	K	N	O	V3	W	W1	W2	ka
802	435	305	225	172.5	82.5	90	125	-	18	213	180	10	14	-	-	98
804	492	342	252	195	91	104	140	-	20	237	200	12	15	-	-	131
806	565	385	285	219.5	102.5	117	160	-	22	269	225	15	17	-	-	183
808	632	432	320	246	116	130	180	-	25	297	250	15	18	-	-	247
810	695	485	360	275	130	145	200	-	27	335	280	20	20	-	-	352
812	785	545	405	307.5	147.5	160	225	-	30	379	315	20	21	-	-	477
814	875	610	450	345	165	180	250	-	33	427	355	20	24	-	-	659
816	950	670	505	388	185	203	280	-	36	479	400	30	-	196	321	917
818	1060	745	570	437.5	207.5	230	315	-	39	541	450	30	-	216	356	1281
820	1195	840	640	492.5	232.5	260	355	-	42	599	500	30	-	241	396	1789
822	1345	945	720	570	300	300	400	-	45	675	560	35	-	266	441	2499
824	1400	1020	810	640	320	320	450	380	48	761	630	35	-	300	480	2972
826	1575	1145	900	715	365	365	500	430	52	855	710	35	-	335	545	3911
828	1797	1301	1010	805	415	415	560	496	56	965	800	40	-	411	575	6211
830	2050	1500	1140	950	470	470	630	550	60	1080	900	45	-	475	665	9411

	Albero entrata / Input shaft / Antriebswelle			Albero uscita / Output shaft / Abtriebswelle								
	ECE 			N 			C 		UB 		B 	
	U	S	G1	T _{m6}	R	M	T _{H7}	M1	T _{H7}	M1	M3	
802	22 i6	40	180	60	112	109	60	109	60	109	170	
804	24 i6	45	200	70	125	121	70	121	70	121	192	
806	28 i6	50	225	80	140	137	80	137	80	137	215	
808	32 k6	56	250	90	160	151	90	151	90	151	246	
810	35 k6	63	280	100	180	170	100	170	100	170	266	
812	40 k6	70	315	110	200	192	110	192	110	192	302	
814	45 k6	80	355	125	225	216	125	216	125	216	335	
816	50 k6	90	400	140	250	242	140	242	140	242	370	
818	55 m6	100	450	160	280	273	160	273	160	273	422	
820	60 m6	112	500	180	315	302	180	302	180	302	477	
822	70 m6	125	560	200	355	340	200	340	200	340	570	
824	80 m6	140	630	220	400	383	220	383	220	383	617	
826	90 m6	160	710	250	450	430	250	430	250	430	685	
828	100 m6	180	800	280	500	485	280	485	280	485	765	
830	110 m6	200	900	320	500	545	320	545	320	545	840	

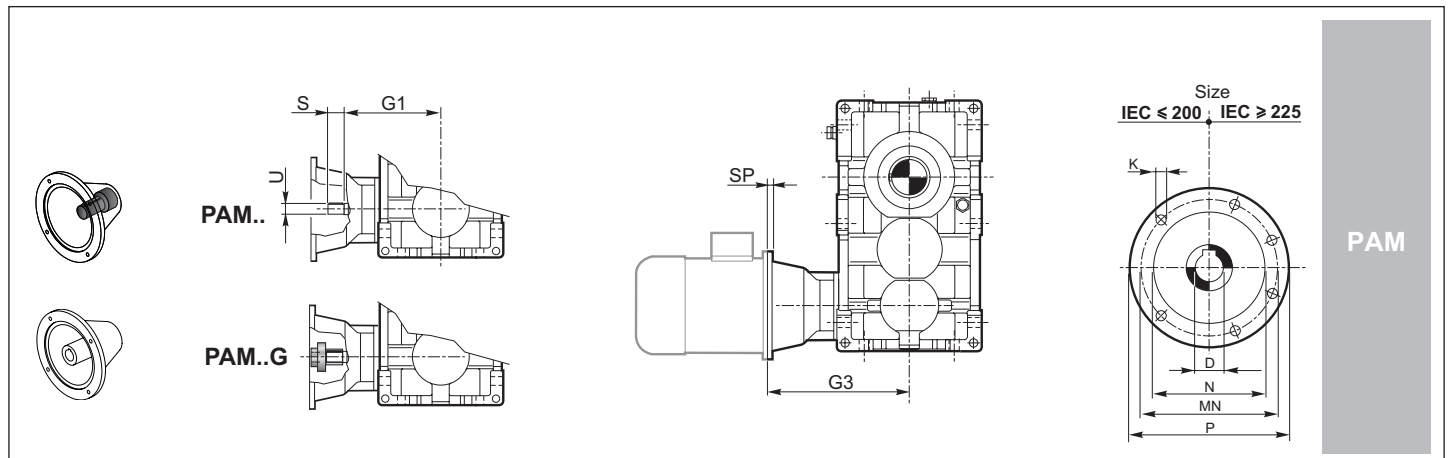

	IEC															
	71	80	90	100	112	132	160	180	200	225	250	280	315	355		
D H7	14	19	24	28	28	38	42	48	55	60	65	75	80	100		
P	160	200	200	250	250	300	350	350	400	450	550	550	660	800		
MN	130	165	165	215	215	265	300	300	350	400	500	500	600	740		
N G6	110	130	130	180	180	230	250	250	300	350	450	450	550	680		
K	M8	M10	M10	M12	M12	M12	M16	M16	M16	M16	M16	M16	M20	M20		
SP	12	12	12	14	14	16	18	18	20	20	20	20	24	30		
G3	802		274	284	284	304	334	334	334							
	804			309	309	329	359	359	359	389						
	806			339	339	359	389	389	389	419						
	808					390	420	420	420	450	450	450				
	810						427	457	457	457	487	487	487	517		
	812							469	499	499	499	529	529	529	559	
	814								549	549	549	579	579	579	609	
	816								604	604	604	634	634	634	664	704
	818									664	694	694	694	694	724	764
	820										756	756	756	756	786	826
822-830																

A richiesta / On request / Auf Anfrage

1.11 Dimensioni
Materiale Carcassa - "Ghisa"

1.11 Dimensions
Housing Material - "Cast Iron"

1.11 Abmessungen
Gehäusematerial - "Guss"

802-820

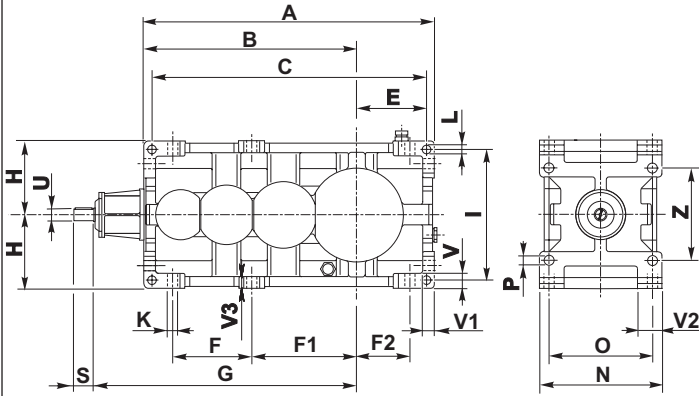

822-826

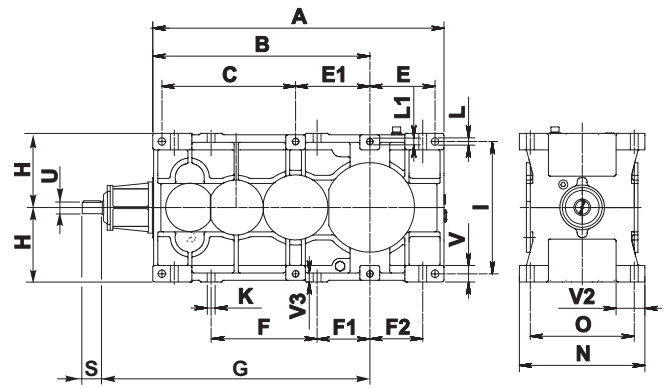

Esecuzione grafica / Shaft arrangement / Grafische Ausführung

Albero uscita / Output shaft / Abtriebswelle

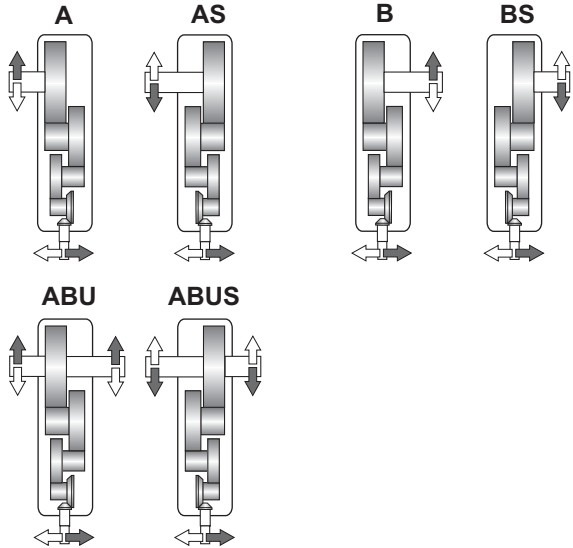

⇒ **N D FD Fn**

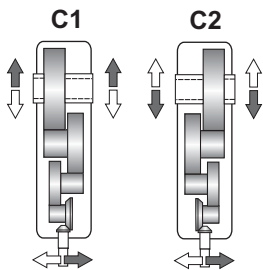
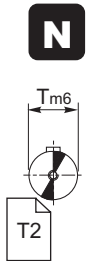
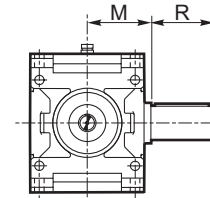

⇒ **C**

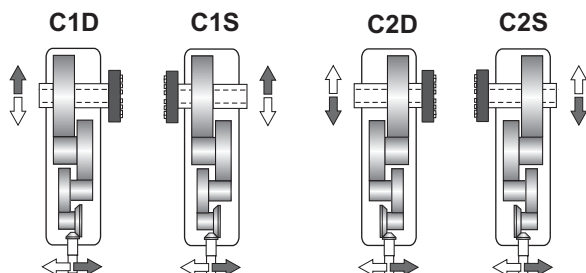
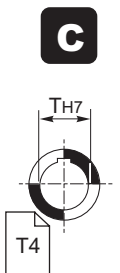
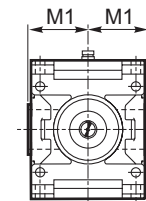

⇒ **UB B CD**

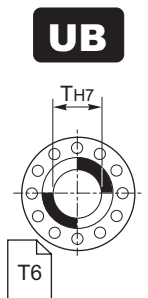
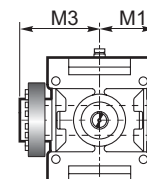
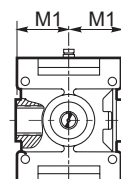

1.11 Dimensioni
Materiale Carcassa - "Ghisa"

1.11 Dimensions
Housing Material - "Cast Iron"

1.11 Abmessungen
Gehäusematerial - "Guss"

RX 800	Dimensioni generali / Dimensions / Allgemeine Abmessungen																			Kg		
	A	B	C	E	E1	F	F1	F2	H h11	I	K	L	L1	N h11	O	P	V	V1	V2		V3	Z
802	498	368	470	116	—	136	182	90	125	224	18	14	—	213	180	18	25	20	44.5	19	160	110
804	562	412	530	134	—	153	202.5	103.5	140	250	20	16	—	237	200	20	28	22.5	49	23	180	139
806	635	465	601	153	—	173	229	117	160	280	22	18	—	269	225	22	32	25	56.5	25	200	204
808	712	522	674	171	—	194	258	130	180	320	25	20	—	297	250	25	36	28	59.5	28	224	284
810	795	585	755	190	—	216	288	144	200	360	27	22	—	335	280	27	40	32	67.5	32	250	393
812	897	657	852	217.5	—	242	324.5	159.5	225	400	30	24	—	379	315	30	45	36	78.5	36	280	545
814	1000	735	950	240	—	271	363	179	250	450	33	27	—	427	355	33	50	40	89	40	320	769
816	1125	825	1069	272	—	305	407.5	202.5	280	500	36	30	—	479	400	36	56	45	96.5	45	360	1056
818	1270	930	1206	308	—	345	460	230	315	560	39	35	—	541	450	39	63	50	114.5	48	400	1475
820	1425	1045	1353	344	—	388	516.5	259.5	355	638	42	39	—	599	500	42	70	56	124	56	450	2060
822	1570	1170	1520	380	400	770	300	300	400	710	45	42	M39	675	560	-	90	-	162	50	-	3011
824	1765	1315	1710	420	450	865	320	320	450	800	48	45	M42	761	630	-	100	-	175	55	-	4111
826	1970	1470	1910	460	500	970	365	365	500	900	52	52	M45	855	710	-	100	-	197	55	-	5161

	Albero entrata / Input shaft / Antriebswelle			Albero uscita / Output shaft / Abtriebswelle											
	ECE			N			G			UB			B		
	U	S	G	T m6	R	M	T H7	M1	T H7	M1	M3				
802	18 j6	32	445	60	112	109	60	109	60	109	60	109	170		
804	20 j6	36	502	70	125	121	70	121	70	121	70	121	192		
806	22 j6	40	565	80	140	137	80	137	80	137	80	137	215		
808	24 j6	45	632	90	160	151	90	151	90	151	90	151	246		
810	28 j6	50	710	100	180	170	100	170	100	170	100	170	266		
812	32 k6	56	795	110	200	192	110	192	110	192	110	192	302		
814	35 k6	63	890	125	225	216	125	216	125	216	125	216	335		
816	40 k6	70	1000	140	250	242	140	242	140	242	140	242	370		
818	45 k6	80	1125	160	280	273	160	273	160	273	160	273	422		
820	50 k6	90	1265	180	315	302	180	302	180	302	180	302	477		
822	55 m6	100	1420	200	355	340	200	340	200	340	200	340	570		
824	60 m6	112	1590	220	400	383	220	383	220	383	220	383	617		
826	70 m6	125	1780	250	450	430	250	430	250	430	250	430	685		

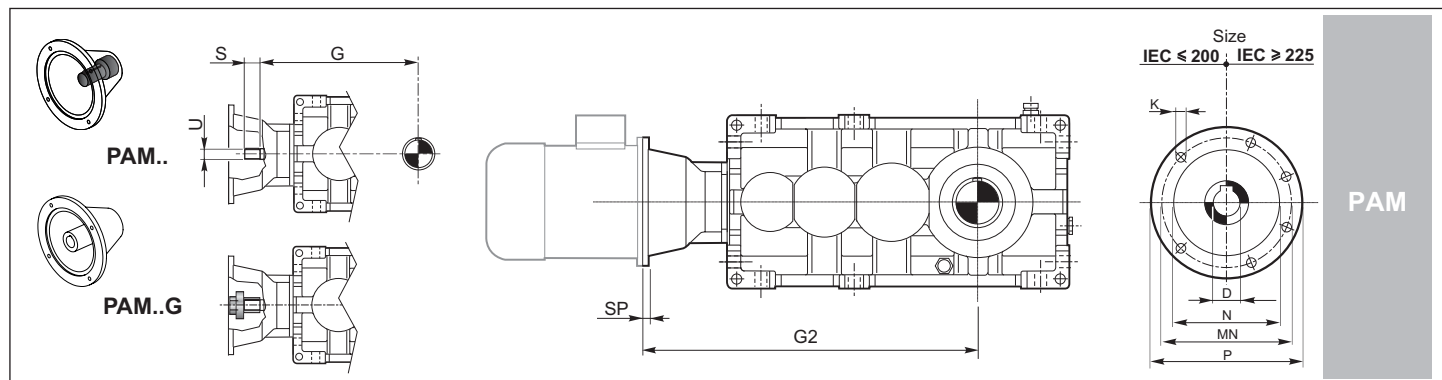

		IEC													
		71	80	90	100	112	132	160	180	200	225	250	280	315	355
D H7		14	19	24	28	28	38	42	48	55	60	65	75	80	100
P		160	200	200	250	250	300	350	350	400	450	550	550	660	800
MN		130	165	165	215	215	265	300	300	350	400	500	500	600	740
N G6		110	130	130	180	180	230	250	250	300	350	450	450	550	680
K		M8	M10	M10	M12	M12	M12	M16	M16	M16	M16	M16	M16	M20	M20
SP		12	12	12	14	14	16	18	18	20	20	20	20	24	30
G2	802	511	521	531	541	541	561								
	804		582	592	602	602	622								
	806		649	659	669	669	689	719							
	808		721	731	741	741	761	791							
	810			814	824	824	844	874	874						
	812			915	915	915	935	965	965	965					
	814				1017	1017	1037	1067	1067	1067	1097				
	816				1134	1134	1154	1184	1184	1184	1214	1214			
	818						1289	1319	1319	1319	1349	1349	1349		
820						1439	1469	1469	1469	1499	1499	1499	1529		
822-826															

A richiesta / On request / Auf Anfrage

1.11 Dimensioni
Materiale Carcassa - "Acciaio"

1.11 Dimensions
Housing Material - "Steel"

1.11 Abmessungen
Gehäusematerial - "Stahl"

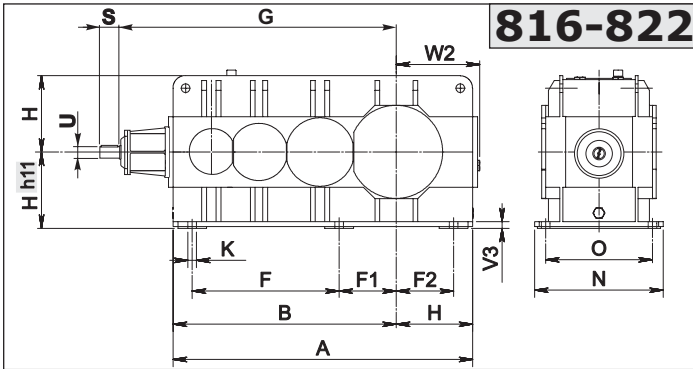
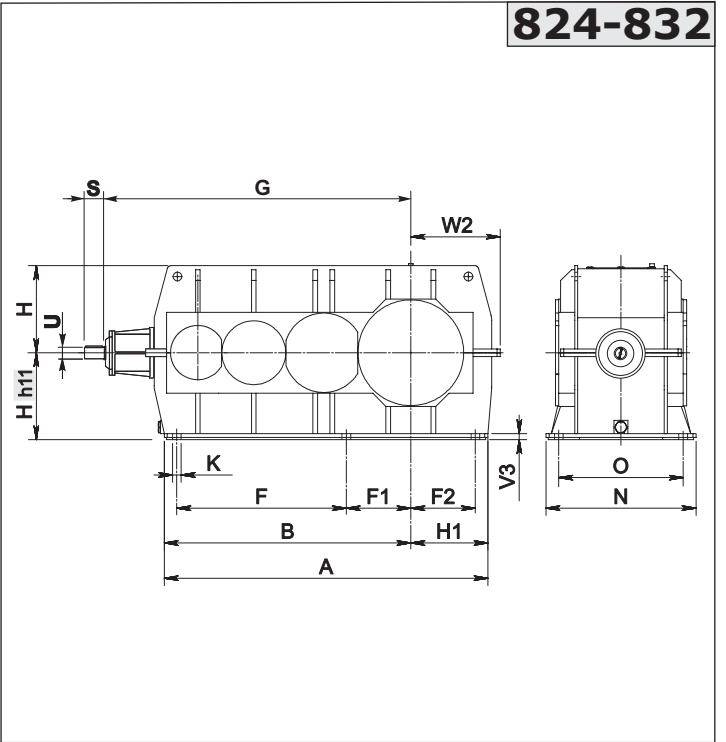
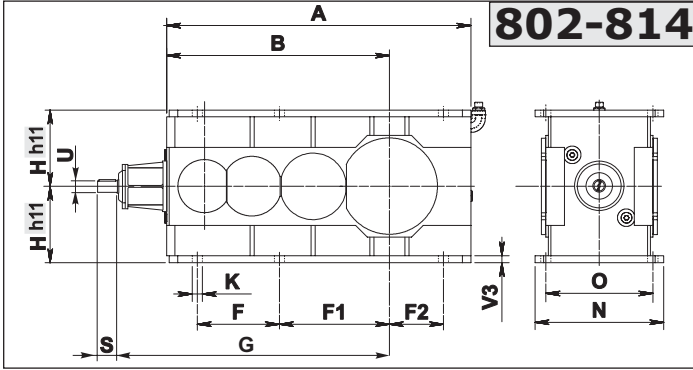

Esecuzione grafica / Shaft arrangement / Grafische Ausführung

Albero uscita / Output shaft / Abtriebswelle

⇒ **N D FD Fn**

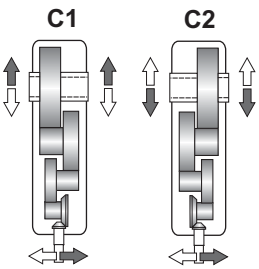
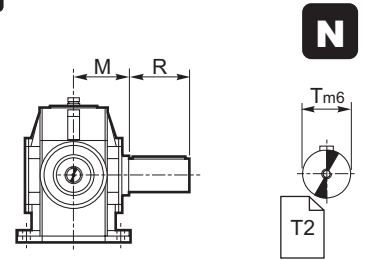
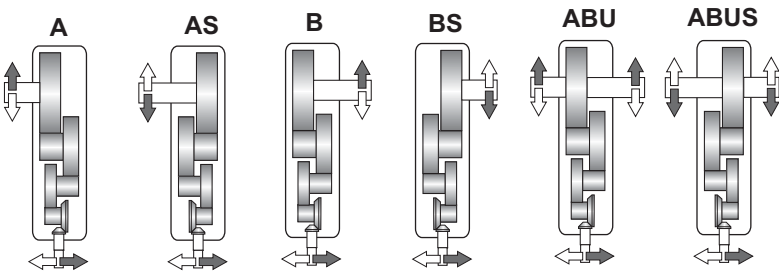

⇒ **G**

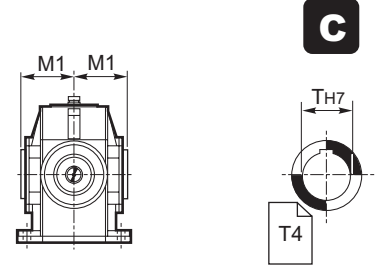

⇒ **UB B CD**

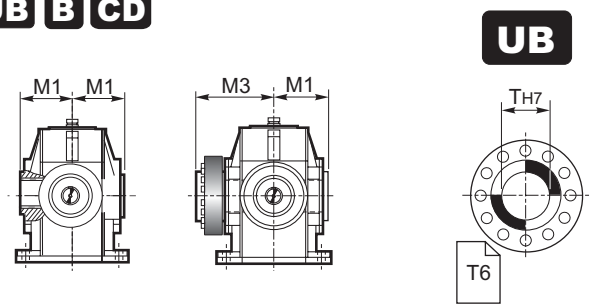
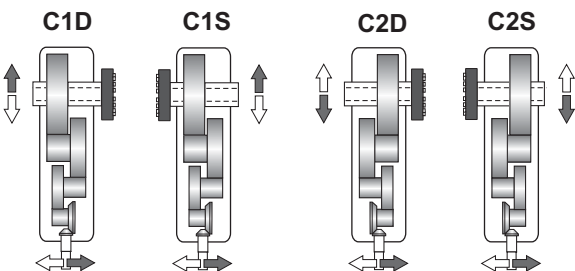





1.11 Dimensioni
Materiale Carcassa - "Acciaio"

1.11 Dimensions
Housing Material - "Steel"

1.11 Abmessungen
Gehäusematerial - "Stahl"

RX 800	Dimensioni generali / Dimensions / Allgemeine Abmessungen												
	A	B	F	F1	F2	H	H1	K	N	O	V3	W2	kq
802	498	368	136	182	90	125	-	18	213	180	10	-	110
804	562	412	153	202.5	103.5	140	-	20	237	200	12	-	139
806	635	465	173	229	117	160	-	22	269	225	15	-	204
808	712	522	194	258	130	180	-	25	297	250	15	-	284
810	795	585	216	288	144	200	-	27	335	280	20	-	393
812	897	657	242	324.5	159.5	225	-	30	379	315	20	-	545
814	1000	735	271	363	179	250	-	33	427	355	20	-	769
816	1105	825	305	407.5	202.5	280	-	36	479	400	30	318	1056
818	1245	930	345	460	230	315	-	39	541	450	30	357	1475
820	1400	1045	388	516.5	259.5	355	-	42	599	500	30	407	2117
822	1570	1170	770	300	300	400	-	45	675	560	35	437	3011
824	1635	1255	865	320	320	450	380	48	761	630	37	480	4011
826	1830	1400	970	365	365	500	430	52	850	710	40	545	4941
828	2082	1586	1090	415	415	560	496	56	965	800	40	575	7111
830	2355	1805	1225	470	470	630	550	60	1080	900	45	665	10511
832	2685	2055	1375	540	540	710	630	60	1180	1000	50	735	13911

	Albero entrata / Input shaft / Antriebswelle			Albero uscita / Output shaft / Abtriebswelle								
	ECE 			N 			G 			UB  B 		
	U	S	G	T m6	R	M	T H7	M1	T H7	M1	M3	
802	18 i6	32	445	60	112	109	60	109	60	109	170	
804	20 i6	36	502	70	125	121	70	121	70	121	192	
806	22 i6	40	565	80	140	137	80	137	80	137	215	
808	24 i6	45	632	90	160	151	90	151	90	151	246	
810	28 i6	50	710	100	180	170	100	170	100	170	266	
812	32 k6	56	795	110	200	192	110	192	110	192	302	
814	35 k6	63	890	125	225	216	125	216	125	216	335	
816	40 k6	70	1000	140	250	242	140	242	140	242	370	
818	45 k6	80	1125	160	280	273	160	273	160	273	422	
820	50 k6	90	1265	180	315	302	180	302	180	302	477	
822	55 m6	100	1420	200	355	340	200	340	200	340	570	
824	60 m6	112	1590	220	400	383	220	383	220	383	617	
826	70 m6	125	1780	250	450	430	250	430	250	430	685	
828	80 m6	140	2000	280	500	485	280	485	280	485	765	
830	90 m6	160	2250	320	500	545	320	545	320	545	840	
832	100 m6	180	2530	360	560	595	360	595	360	595	930	

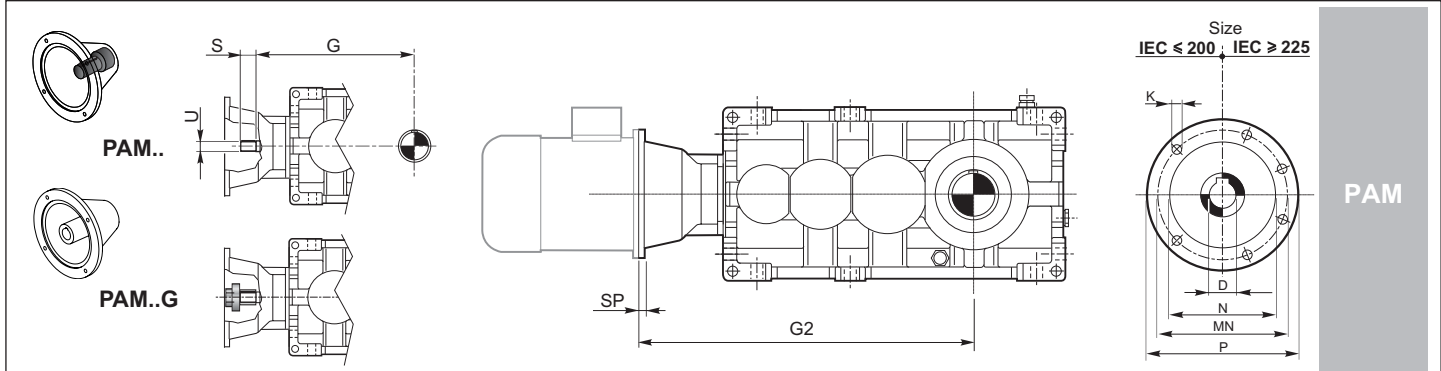

	IEC														
	71	80	90	100	112	132	160	180	200	225	250	280	315	355	
D H7	14	19	24	28	28	38	42	48	55	60	65	75	80	100	
P	160	200	200	250	250	300	350	350	400	450	550	550	660	800	
MN	130	165	165	215	215	265	300	300	350	400	500	500	600	740	
N G6	110	130	130	180	180	230	250	250	300	350	450	450	550	680	
K	M8	M10	M10	M12	M12	M12	M16	M16	M16	M16	M16	M16	M20	M20	
SP	12	12	12	14	14	16	18	18	20	20	20	20	24	30	
G2	802	511	521	531	541	541	561								
	804		582	592	602	602	622								
	806		649	659	669	669	689	719							
	808		721	731	741	741	761	791							
	810			814	824	824	844	874	874						
	812			915	915	915	935	965	965	965					
	814				1017	1017	1037	1067	1067	1067	1097				
	816				1134	1134	1154	1184	1184	1184	1214	1214			
	818						1289	1319	1319	1319	1349	1349	1349		
820						1439	1469	1469	1469	1499	1499	1499	1529		
822-832	A richiesta / On request / Auf Anfrage														

1.11 Dimensioni
Materiale Carcassa - "Ghisa"

1.11 Dimensions
Housing Material - "Cast Iron"

1.11 Abmessungen
Gehäusematerial - "Guss"

802-820

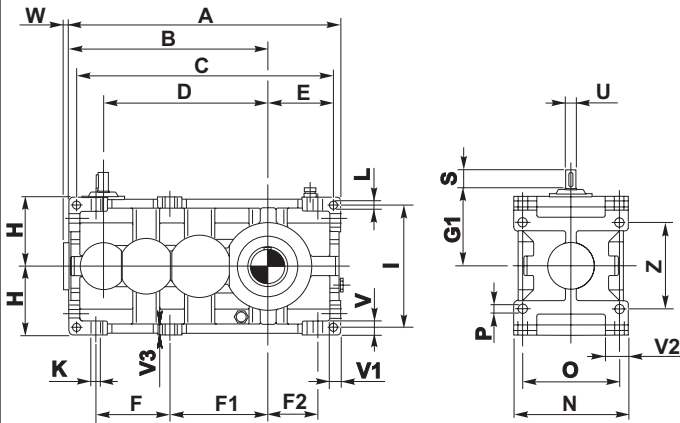

822-826

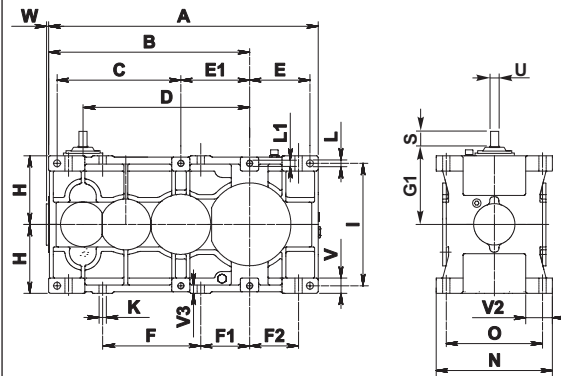

Esecuzione grafica / Shaft arrangement / Grafische Ausführung

Albero uscita / Output shaft / Abtriebswelle

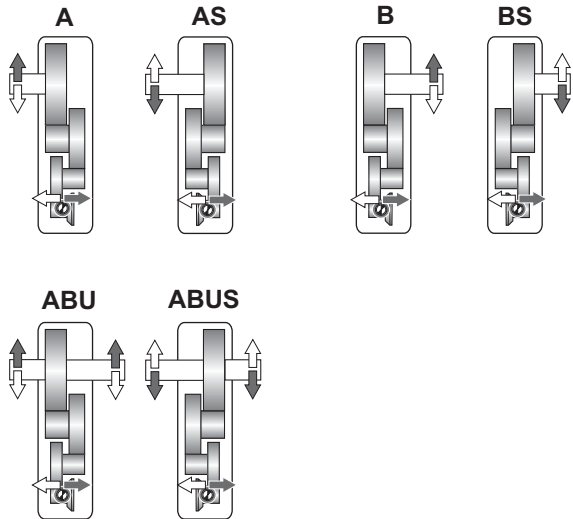

⇒ **N D FD Fn**

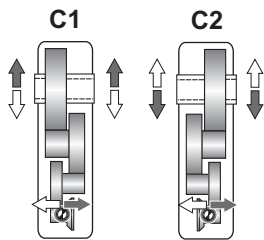
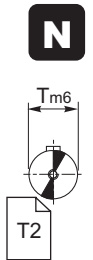
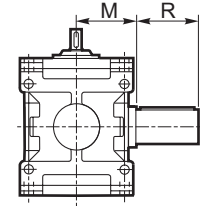

⇒ **C**

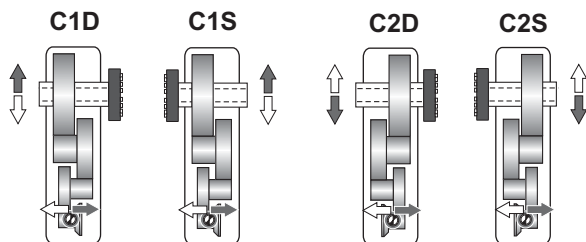
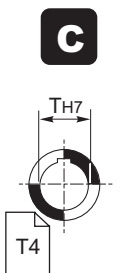
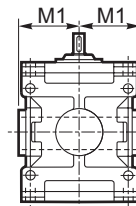

⇒ **UB B CD**

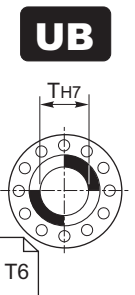
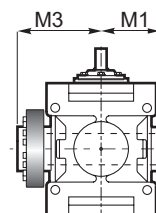
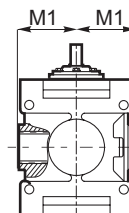





1.11 Dimensioni
Materiale Carcassa - "Ghisa"

1.11 Dimensions
Housing Material - "Cast Iron"

1.11 Abmessungen
Gehäusematerial - "Guss"

RX 800	Dimensioni generali / Dimensions / Allgemeine Abmessungen																				Kg			
	A	B	C	D	E	E1	F	F1	F2	H h11	I	K	L	L1	N h11	O	P	V	V1	V2		V3	W	Z
802	498	368	470	305	116	—	136	182	90	125	224	18	14	—	213	180	18	25	20	44.5	19	11	160	110
804	562	412	530	342	134	—	153	202.5	103.5	140	250	20	16	—	237	200	20	28	22.5	49	23	14	180	139
806	635	465	601	385	153	—	173	229	117	160	280	22	18	—	269	225	22	32	25	56.5	25	16	200	204
808	712	522	674	432	171	—	194	258	130	180	320	25	20	—	297	250	25	36	28	59.5	28	16	224	284
810	795	585	755	485	190	—	216	288	144	200	360	27	22	—	335	280	27	40	32	67.5	32	18	250	393
812	897	657	852	545	217.5	—	242	324.5	159.5	225	400	30	24	—	379	315	30	45	36	78.5	36	19	280	545
814	1000	735	950	610	240	—	271	363	179	250	450	33	27	—	427	355	33	50	40	89	40	22	320	769
816	1125	825	1069	685	272	—	305	407.5	202.5	280	500	36	30	—	479	400	36	56	45	96.5	45	21	360	1056
818	1270	930	1206	770	308	—	345	460	230	315	560	39	35	—	541	450	39	63	50	114.5	48	24	400	1475
820	1425	1045	1353	865	344	—	388	516.5	259.5	355	638	42	39	—	599	500	42	70	56	124	56	28	450	2060
822	1570	1170	1470	970	380	—	431	580	290	400	710	45	42	M39	675	560	-	90	-	162	50	29	-	3011
824	1765	1315	1615	1070	420	—	474	645	320	450	800	48	45	M42	761	630	-	100	-	175	55	30	-	4111
826	1970	1470	1770	1120	460	—	517	710	350	500	900	52	52	M45	855	710	-	100	-	197	55	33	-	5161

	Albero entrata / Input shaft / Antriebswelle			Albero uscita / Output shaft / Abtriebswelle								
	ECE 			N 			G 		UB 		B 	
	U	S	G1	T m6	R	M	T H7	M1	T H7	M1	M3	
802	18 j6	32	140	60	112	109	60	109	60	109	170	
804	20 j6	36	160	70	125	121	70	121	70	121	192	
806	22 j6	40	180	80	140	137	80	137	80	137	215	
808	24 j6	45	200	90	160	151	90	151	90	151	246	
810	28 j6	50	225	100	180	170	100	170	100	170	266	
812	32 k6	56	250	110	200	192	110	192	110	192	302	
814	35 k6	63	280	125	225	216	125	216	125	216	335	
816	40 k6	70	315	140	250	242	140	242	140	242	370	
818	45 k6	80	355	160	280	273	160	273	160	273	422	
820	50 k6	90	400	180	315	302	180	302	180	302	477	
822	55 m6	100	450	200	355	340	200	340	200	340	570	
824	60 m6	112	500	220	400	383	220	383	220	383	617	
826	70 m6	125	560	250	450	430	250	430	250	430	685	

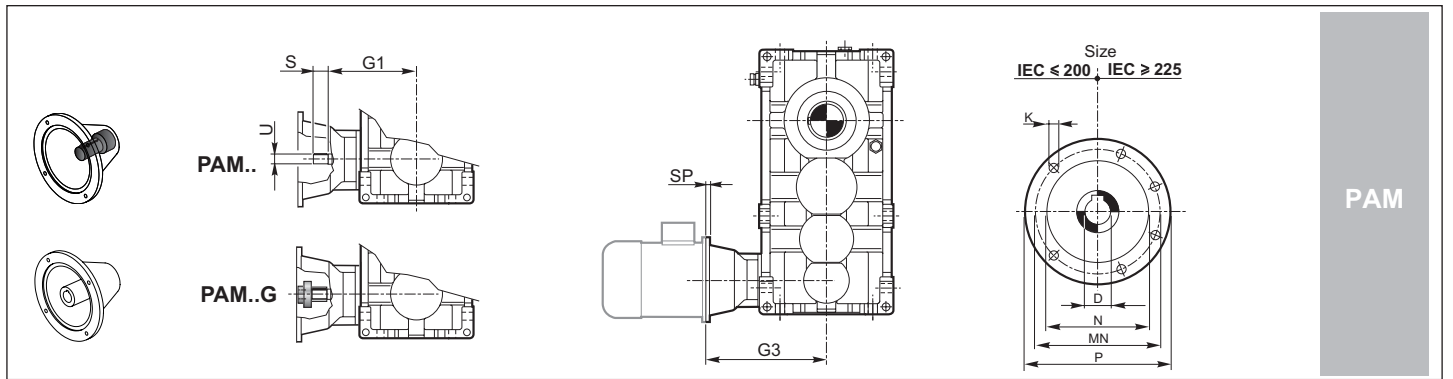

	IEC														
	71	80	90	100	112	132	160	180	200	225	250	280	315	355	
D H7	14	19	24	28	28	38	42	48	55	60	65	75	80	100	
P	160	200	200	250	250	300	350	350	400	450	550	550	660	800	
MN	130	165	165	215	215	265	300	300	350	400	500	500	600	740	
N G6	110	130	130	180	180	230	250	250	300	350	450	450	550	680	
K	M8	M10	M10	M12	M12	M12	M16	M16	M16	M16	M16	M16	M20	M20	
SP	12	12	12	14	14	16	18	18	20	20	20	20	24	30	
G3	802	206	216	226	236	256									
	804		240	250	260	280									
	806		264	274	284	284	304	334							
	808		289	299	309	309	329	359							
	810			329	339	339	359	389	389						
	812			370	370	370	390	420	420	420					
	814				407	407	427	457	457	457	487				
	816				449	449	469	499	499	499	529	529			
818						519	549	549	549	579	579	579			
820						574	604	604	604	634	634	634	664		
822-826	A richiesta / On request / Auf Anfrage														

1.11 Dimensioni
Materiale Carcassa - "Acciaio"

1.11 Dimensions
Housing Material - "Steel"

1.11 Abmessungen
Gehäusematerial - "Stahl"

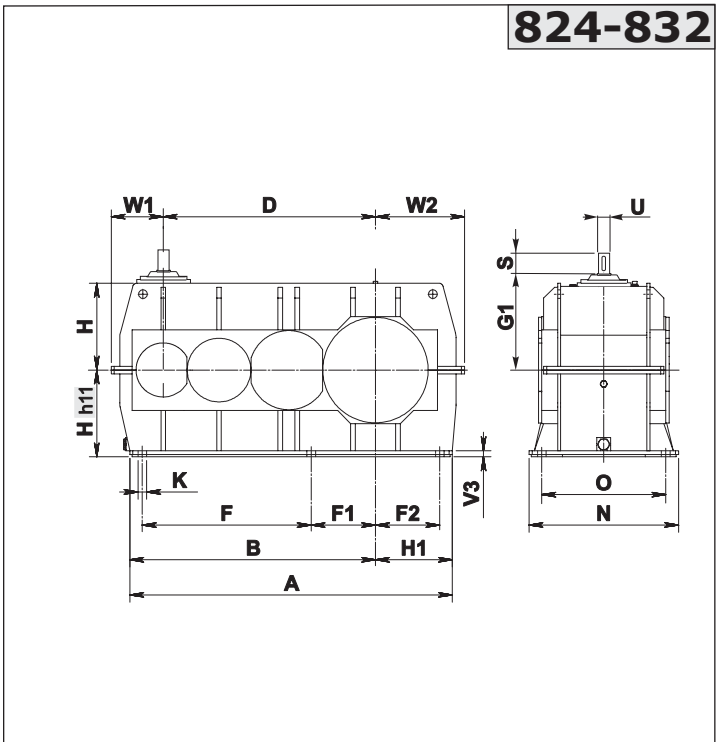
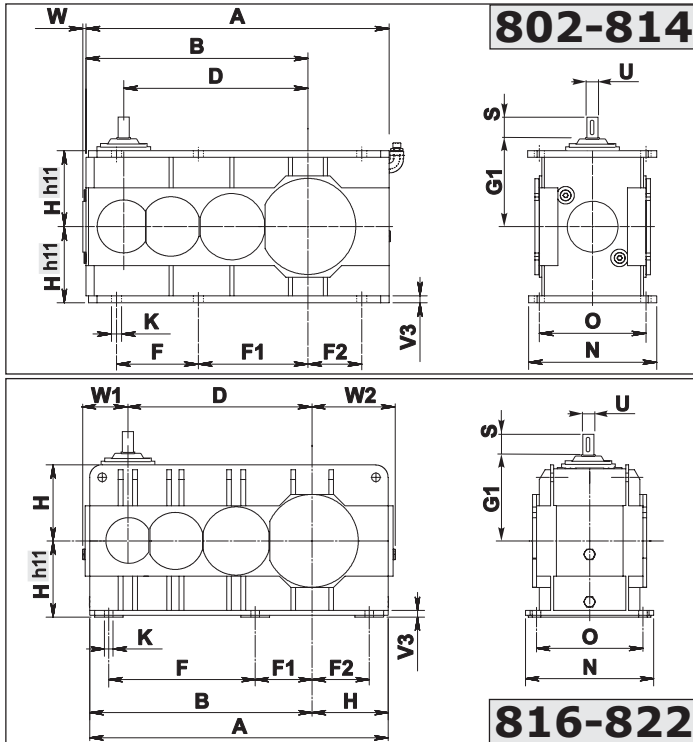

Esecuzione grafica / Shaft arrangement / Grafische Ausführung

Albero uscita / Output shaft / Abtriebswelle

⇒ **N D FD Fn**

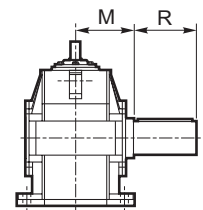
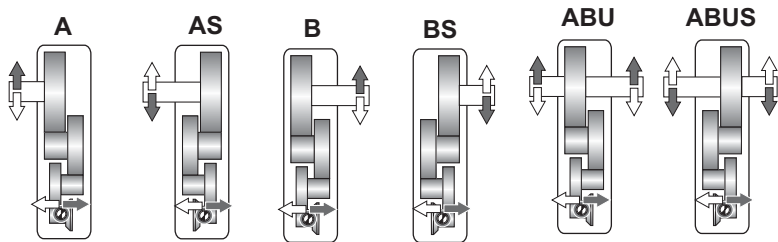

N

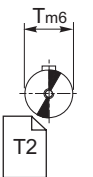

⇒ **G**

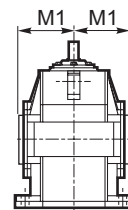
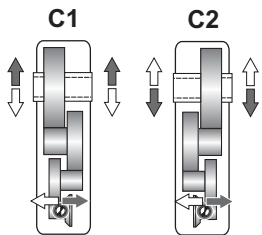

G

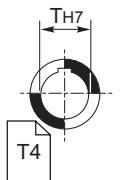

⇒ **UB B CD**

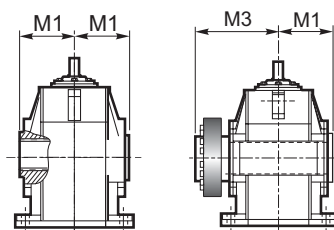
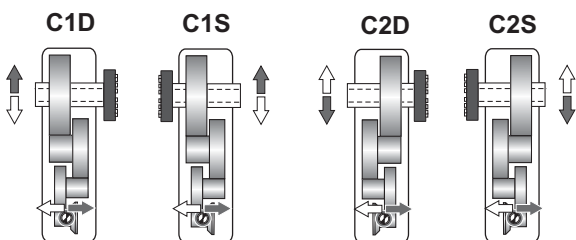

UB

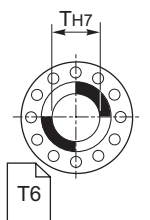

1.11 Dimensioni
Materiale Carcassa - "Acciaio"

1.11 Dimensions
Housing Material - "Steel"

1.11 Abmessungen
Gehäusematerial - "Stahl"

RX 800	Dimensioni generali / Dimensions / Allgemeine Abmessungen															
	A	B	D	F	F1	F2	H	H1	K	N	O	V3	W	W1	W2	kg
802	498	368	305	136	182	90	125	-	18	213	180	10	11	-	-	110
804	562	412	342	153	202.5	103.5	140	-	20	237	200	12	14	-	-	139
806	635	465	385	173	229	117	160	-	22	269	225	15	16	-	-	204
808	712	522	432	194	258	130	180	-	25	297	250	15	16	-	-	284
810	795	585	485	216	288	144	200	-	27	335	280	20	18	-	-	393
812	897	657	545	242	324.5	159.5	225	-	30	379	315	20	19	-	-	545
814	1000	735	610	271	363	179	250	-	33	427	355	20	22	-	-	769
816	1105	825	685	305	407.5	202.5	280	-	36	479	400	30	-	178	318	1056
818	1245	930	770	345	460	230	315	-	39	541	450	30	-	202	357	1475
820	1400	1045	865	388	516.5	259.5	355	-	42	599	500	30	-	232	407	2117
822	1570	1170	970	440	600	300	400	-	45	675	560	35	-	237	437	3011
824	1635	1255	1090	465	645	320	450	380	48	761	630	37	-	265	480	4011
826	1830	1400	1220	510	740	365	500	430	52	850	710	40	-	295	545	4941
828	2082	1586	1370	560	820	415	560	496	56	965	800	40	-	336	575	7111
830	2355	1805	1540	620	940	470	630	550	60	1080	900	45	-	380	665	10511
832	2685	2055	1730	680	1060	540	710	630	60	1180	1000	50	-	430	735	13911

	Albero entrata / Input shaft / Antriebswelle			Albero uscita / Output shaft / Abtriebswelle								
	ECE			N			G		UB		B	
	U	S	G1	T m6	R	M	T H7	M1	T H7	M1	M3	
802	18 i6	32	140	60	112	109	60	109	60	109	170	
804	20 i6	36	160	70	125	121	70	121	70	121	192	
806	22 i6	40	180	80	140	137	80	137	80	137	215	
808	24 i6	45	200	90	160	151	90	151	90	151	246	
810	28 i6	50	225	100	180	170	100	170	100	170	266	
812	32 k6	56	250	110	200	192	110	192	110	192	302	
814	35 k6	63	280	125	225	216	125	216	125	216	335	
816	40 k6	70	315	140	250	242	140	242	140	242	370	
818	45 k6	80	355	160	280	273	160	273	160	273	422	
820	50 k6	90	400	180	315	302	180	302	180	302	477	
822	55 m6	100	450	200	355	340	200	340	200	340	570	
824	60 m6	112	500	220	400	383	220	383	220	383	617	
826	70 m6	125	560	250	450	430	250	430	250	430	685	
828	80 m6	140	630	280	500	485	280	485	280	485	765	
830	90 m6	160	710	320	500	545	320	545	320	545	840	
832	100 m6	180	800	360	560	595	360	595	360	595	930	

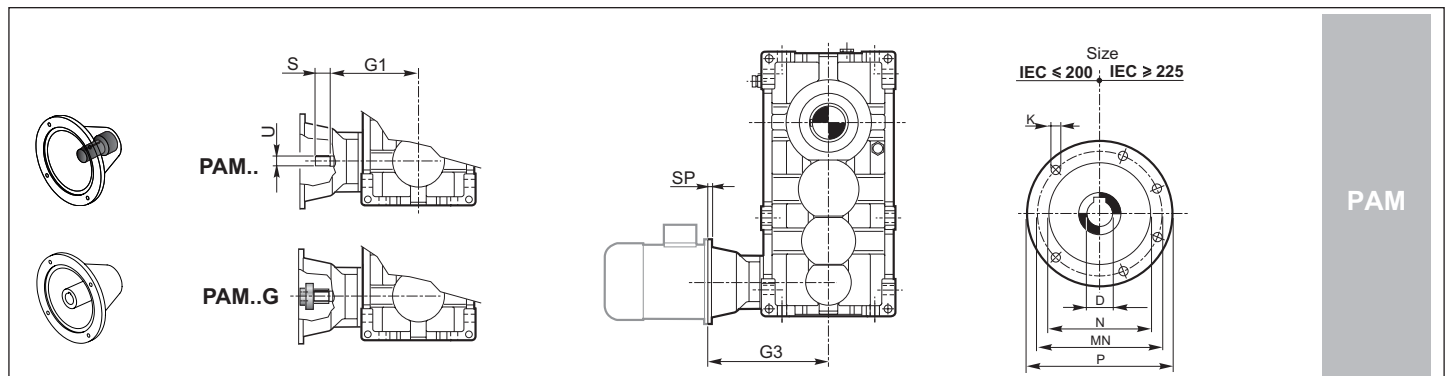

		IEC														
		71	80	90	100	112	132	160	180	200	225	250	280	315	355	
D H7		14	19	24	28	28	38	42	48	55	60	65	75	80	100	
P		160	200	200	250	250	300	350	350	400	450	550	550	660	800	
MN		130	165	165	215	215	265	300	300	350	400	500	500	600	740	
N G6		110	130	130	180	180	230	250	250	300	350	450	450	550	680	
K		M8	M10	M10	M12	M12	M12	M16	M16	M16	M16	M16	M16	M20	M20	
SP		12	12	12	14	14	16	18	18	20	20	20	20	24	30	
G3	802	206	216	226	236	236	256									
	804		240	250	260	260	280									
	806		264	274	284	284	304	334								
	808		289	299	309	309	329	359								
	810			329	339	339	359	389	389							
	812			370	370	370	390	420	420	420						
	814				407	407	427	457	457	457	487					
	816				449	449	469	499	499	499	529	529				
	818						519	549	549	549	579	579	579			
820						574	604	604	604	634	634	634	664			
822-832																

A richiesta / On request / Auf Anfrage

802-816

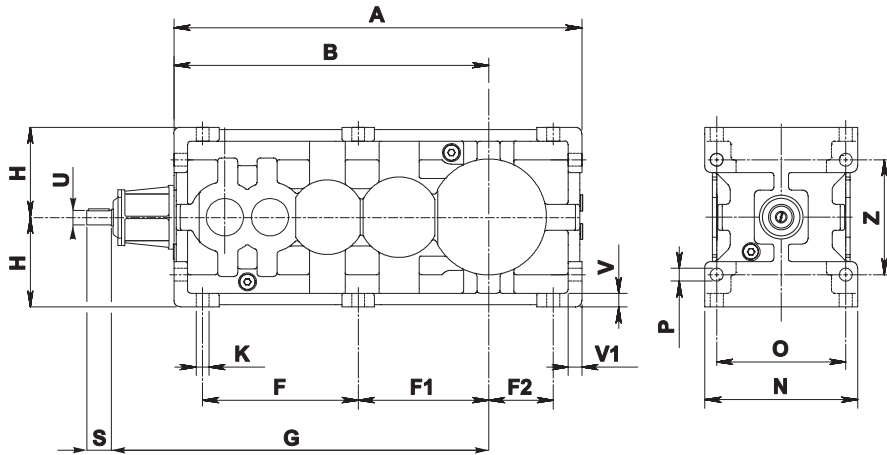

Esecuzione grafica / Shaft arrangement / Grafische Ausführung

Albero uscita / Output shaft / Abtriebswelle

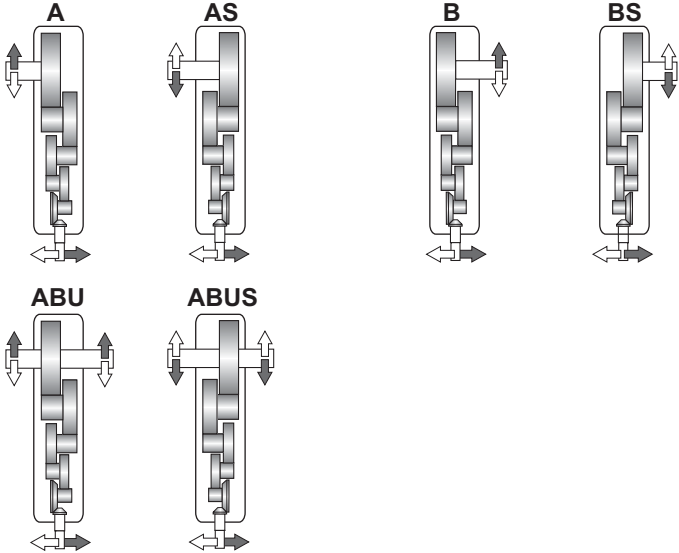

⇒ **N D FD Fn**

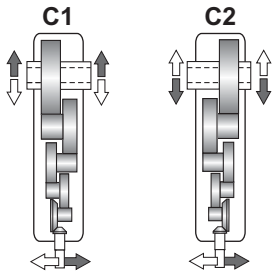
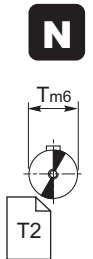
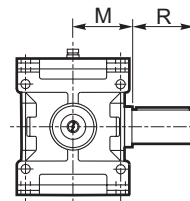

⇒ **C**

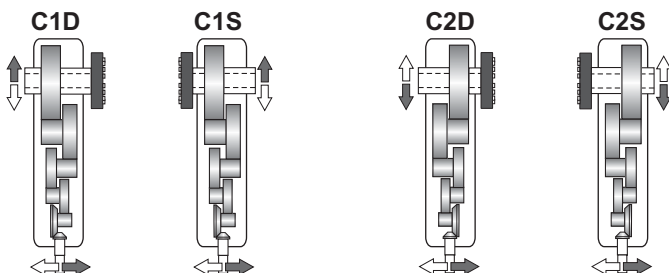
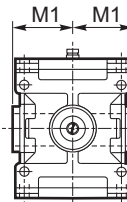

⇒ **UB B CD**

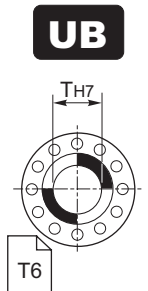
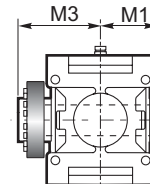
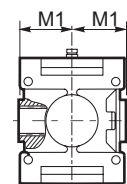

1.11 Dimensioni
Materiale Carcassa - "Ghisa"

1.11 Dimensions
Housing Material - "Cast Iron"

1.11 Abmessungen
Gehäusematerial - "Guss"

RX 800	Dimensioni generali / Dimensions / Allgemeine Abmessungen													Kg
	A	B	F	F1	F2	H _{h11}	K	N _{h11}	O	P	V	V1	Z	
802	569	439	217	182	90	125	18	213	180	18	19	19	160	110
804	626	476	229	202.5	103.5	140	20	237	200	20	21	21	180	135
806	718	548	266	229	117	160	22	269	225	22	25	25	200	205
808	785	595	280	258	130	180	25	297	250	25	28	28	224	285
810	901	691	337	288	144	200	27	335	280	27	32	32	250	395
812	991	751	355	324.5	159.5	225	30	379	315	30	36	36	280	555
814	1136	871	422	363	179	250	33	427	355	33	40	40	320	780
816	1246	946	441	407.5	202.5	280	36	479	400	36	45	45	360	1070

	Albero entrata / Input shaft / Antriebswelle			Albero uscita / Output shaft / Abtriebswelle								
	ECE			N			G			UB	B	
	U	S	G	T m6	R	M	T H7	M1	T H7	M1	M3	
802	14 j6	30	479	60	112	109	60	109	60	109	170	
804	14 j6	30	516	70	125	121	70	121	70	121	192	
806	19 j6	40	586	80	140	137	80	137	80	137	215	
808	19 j6	40	633	90	160	151	90	151	90	151	246	
810	24 j6	50	737	100	180	170	100	170	100	170	266	
812	24 j6	50	797	110	200	192	110	192	110	192	302	
814	28 j6	60	921	125	225	216	125	216	125	216	335	
816	28 j6	60	996	140	250	242	140	242	140	242	370	

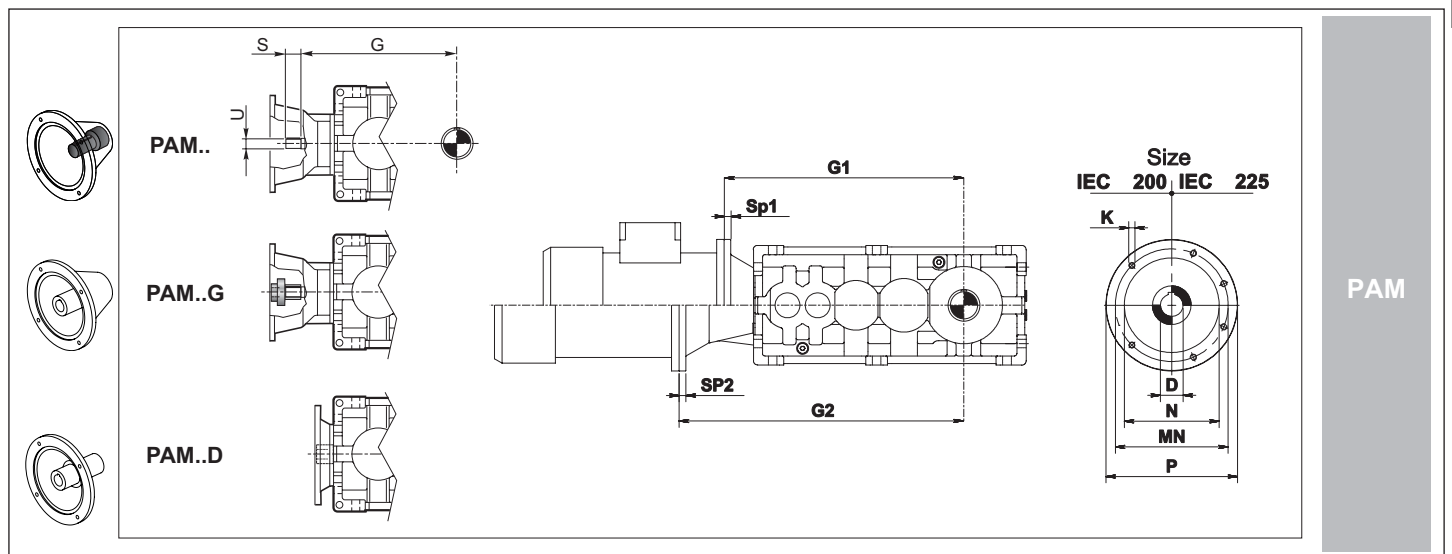

	IEC							
	71	80	90	100	112	132	160	180
D H7	14	19	24	28	28	38	42	48
P	160	200	200	250	250	300	350	350
MN	130	165	165	215	215	265	300	300
N G6	110	130	130	180	180	230	250	250
K	M8	M10	M10	M12	M12	M12	M16	M16
SP	12	12	12	14	14	16	18	18
G1/G2	802	509 / 543	509 / 564	509 / 564				
	804	546 / 580	546 / 601	546 / 601				
	806	620 / 660	620 / 681	620 / 681	620 / 691	620 / 691		
	808	667 / 707	667 / 728	667 / 728	667 / 738	667 / 738		
	810		788 / 842	788 / 842	788 / 852	788 / 852	788 / 872	
	812		848 / 902	848 / 902	848 / 912	848 / 912	848 / 932	
	814			970 / -	970 / 1047	970 / 1047	970 / 1000*	- / 1009*
	816			1045 / -	1045 / 1122	1045 / 1122	1045 / 1075*	- / 1084*

* Solo PAM...G - forniti con giunto tipo Rotex.

* Only PAM...G - come with Rotex coupling.

* nur PAM...G - Werden sie mit Kupplung Typ Rotex geliefert.

802-816

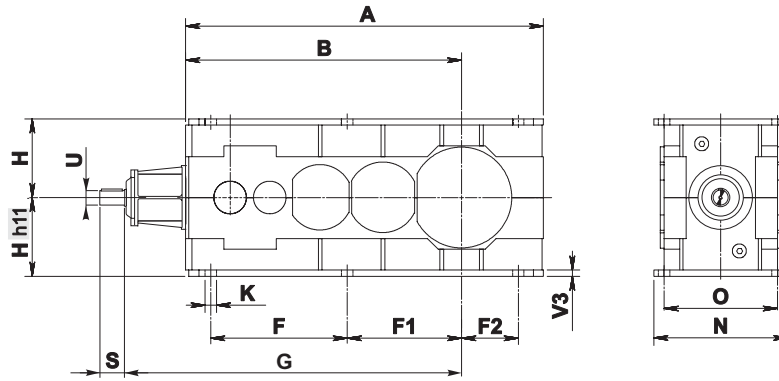

Esecuzione grafica / Shaft arrangement / Grafische Ausführung

Albero uscita / Output shaft / Abtriebswelle

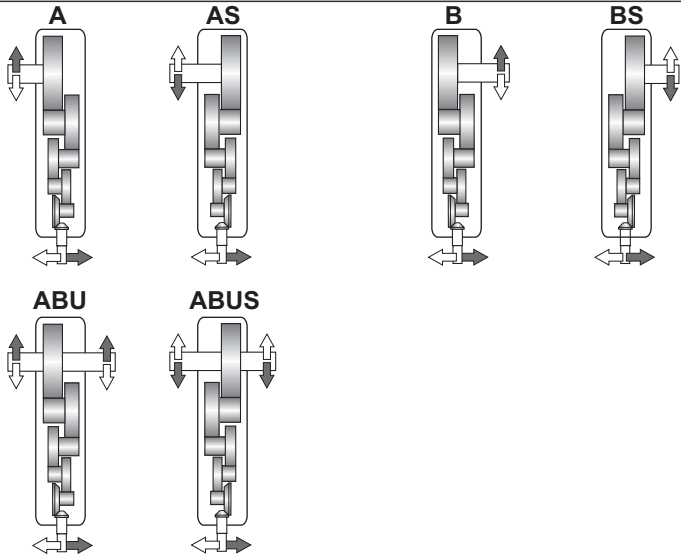

➔ **N D FD Fn**

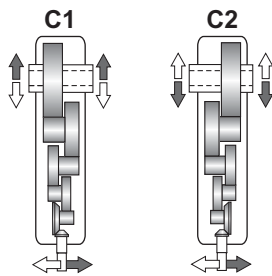
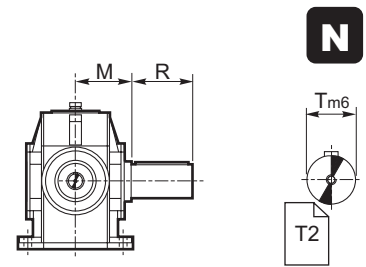

➔ **C**

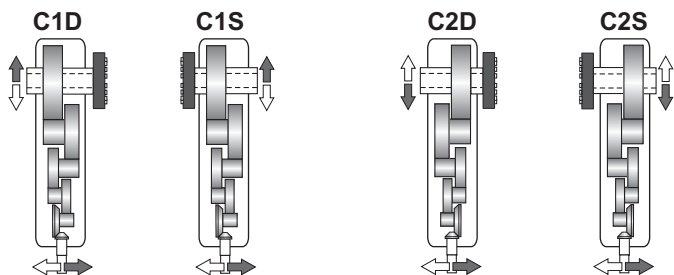
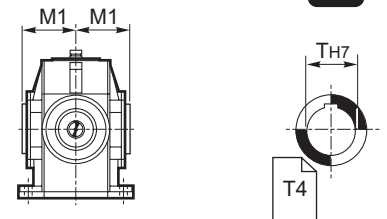

➔ **UB B CD**

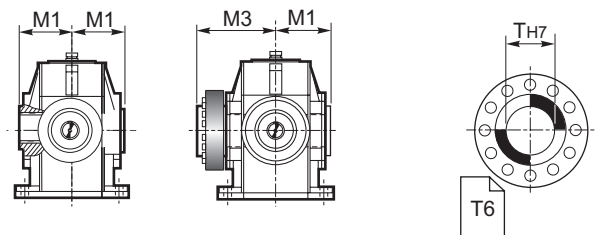





**1.11 Dimensioni
Materiale Carcassa - "Acciaio"**

**1.11 Dimensions
Housing Material - "Steel"**

**1.11 Abmessungen
Gehäusematerial - "Stahl"**

RX 800	Dimensioni generali / Dimensions / Allgemeine Abmessungen											
	A	B	F	F1	F2	H h11	H1	K	N h11	O	V3	Kg
802	569	439	217	182	90	125	-	18	213	180	10	110
804	626	476	229	202.5	103.5	140	-	20	237	200	12	135
806	718	548	266	229	117	160	-	22	269	225	15	200
808	785	595	280	258	130	180	-	25	297	250	15	280
810	901	691	337	288	144	200	-	27	335	280	20	390
812	991	751	355	324.5	159.5	225	-	30	379	315	20	550
814	1136	871	422	363	179	250	-	33	427	355	20	770
816	1246	946	441	407.5	202.5	280	-	36	479	400	20	1060

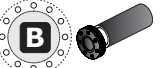
	Albero entrata / Input shaft / Antriebswelle			Albero uscita / Output shaft / Abtriebswelle								
	ECE 			N 			G 		UB 		B 	
	U	S	G	T m6	R	M	T H7	M1	T H7	M1	M3	
802	14 j6	30	479	60	112	109	60	109	60	109	170	
804	14 j6	30	516	70	125	121	70	121	70	121	192	
806	19 j6	40	586	80	140	137	80	137	80	137	215	
808	19 j6	40	633	90	160	151	90	151	90	151	246	
810	24 j6	50	737	100	180	170	100	170	100	170	266	
812	24 j6	50	797	110	200	192	110	192	110	192	302	
814	28 j6	60	921	125	225	216	125	216	125	216	335	
816	28 j6	60	996	140	250	242	140	242	140	242	370	

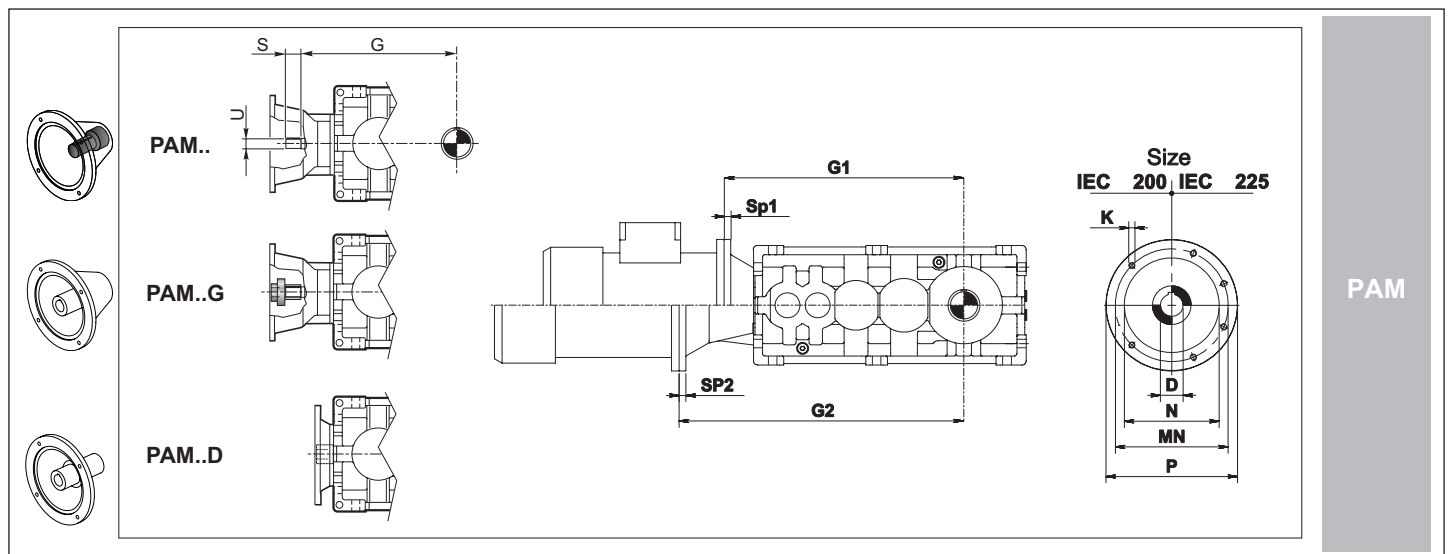

		IEC							
		71	80	90	100	112	132	160	180
D	H7	14	19	24	28	28	38	42	48
P		160	200	200	250	250	300	350	350
MN		130	165	165	215	215	265	300	300
N	G6	110	130	130	180	180	230	250	250
K		M8	M10	M10	M12	M12	M12	M16	M16
SP		12	12	12	14	14	16	18	18
G1/G2	802	509 / 543	509 / 564	509 / 564					
	804	546 / 580	546 / 601	546 / 601					
	806	620 / 660	620 / 681	620 / 681	620 / 691	620 / 691			
	808	667 / 707	667 / 728	667 / 728	667 / 738	667 / 738			
	810		788 / 842	788 / 842	788 / 852	788 / 852	788 / 872		
	812		848 / 902	848 / 902	848 / 912	848 / 912	848 / 932		
	814			970 / -	970 / 1047	970 / 1047	970 / 1000*	- / 1009*	- / 1009*
816			1045 / -	1045 / 1122	1045 / 1122	1045 / 1075*	- / 1084*	- / 1084*	

* Solo PAM...G - forniti con giunto tipo Rotex.

* Only PAM...G - come with Rotex coupling.

* nur PAM...G - Werden sie mit Kupplung Typ Rotex geliefert.

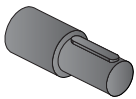

1.12 - Estremità d'albero entrata

1.12 - Input shaft end

1.12 - Ende der Antriebswelle

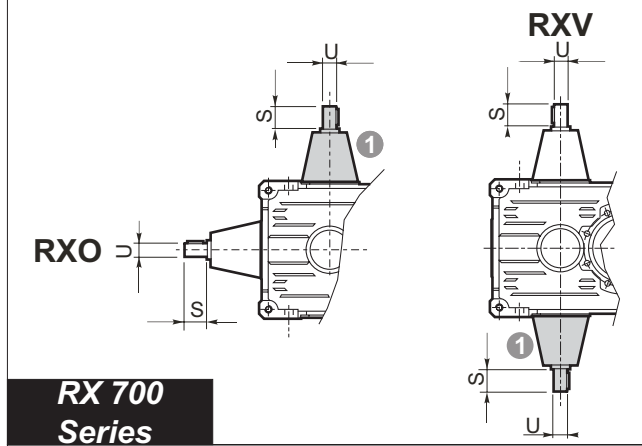

RX 700 Series

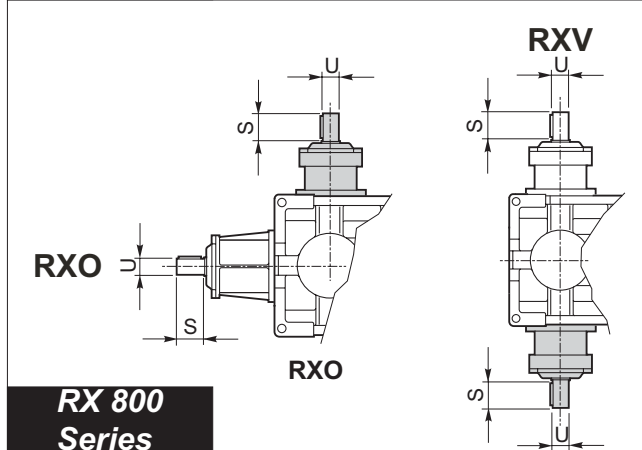

RX 800 Series

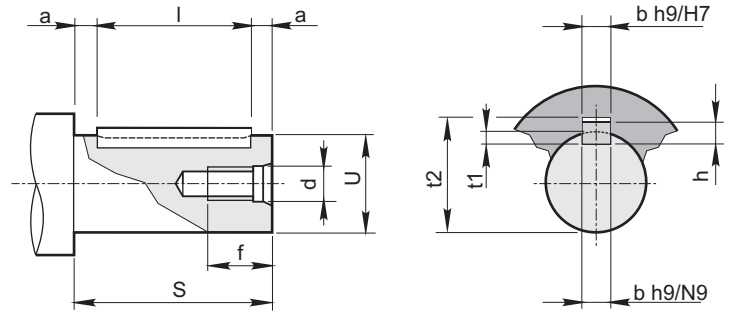

Estremità supplementare
Additional shaft extension
Zusätzliches Ende

1
A richiesta
On request
Auf Anfrage

RX 800 Series

RXO 1 RXV 1			RXO 2 RXV 2			RXO 3 RXV 3			Foro fil. testa Tapped hole Gewindebohrung Kopf		Cava Keyway Nut			Estremità d'albero Shaft end Wellenend			Linguetta Key Federkeil
Size	U	S	Size	U	S	Size	U	S	d	f	b	t ₁	t ₂	U	S _{a11}	a	b x h x l
802	28 j6	50	802	22 j6	40	802	18 j6	32	M6	18	6	3.5	20.8	18 j6	32	2	6x6x28
804	32 k6	56	804	24 j6	45	804	20 j6	36	M6	18	6	3.5	22.8	20 j6	36	2	6x6x32
806	35 k6	63	806	28 j6	50	806	22 j6	40	M6	18	6	3.5	24.8	22 j6	40	2.5	6x6x35
808	40 k6	70	808	32 k6	56	808	24 j6	45	M8	22	8	4	27.3	24 j6	45	2.5	8x7x40
810	45 k6	80	810	35 k6	63	810	28 j6	50	M8	22	8	4	31.3	28 j6	50	2.5	8x7x45
812	50 m6	90	812	40 k6	70	812	32 k6	56	M8	22	10	5	35.3	32 k6	56	3	10x8x50
814	55 m6	100	814	45 k6	80	814	35 k6	63	M10	27	10	5	38.3	35 k6	63	4	10x8x55
816	60 m6	112	816	50 m6	90	816	40 k6	70	M10	27	12	5	43.3	40 k6	70	5	12x8x60
818	70 m6	125	818	55 m6	100	818	45 k6	80	M10	27	14	5.5	48.8	45 k6	80	5	14x9x70
820	80 m6	140	820	60 m6	112	820	50 m6	90	M12	35	14	5.5	53.8	50 m6	90	5	14x9x80
822	90 m6	160	822	65 m6	125	822	55 m6	100	M12	35	16	6	59.3	55 m6	100	5	16x10x90
824	100 m6	180	824	70 m6	125	824	60 m6	112	M12	35	18	7	64.4	60 m6	112	6	18x11x100
			826	80 m6	140	826	70 m6	125	M16	39	20	7.5	74.9	70 m6	125	7.5	20x12x110
			828	90 m6	160	828	80 m6	140	M16	39	22	9	85.4	80 m6	140	7.5	22x14x125
			830	100 m6	180	830	90 m6	160	M16	39	25	9	95.4	90 m6	160	10	25x14x140
			832	110 m6	200	832	100 m6	180	M20	46	28	10	106.4	100 m6	180	10	28x16x160
									M20	46	28	10	116.4	110 m6	200	10	28x16x180

RX 700 Series			RX 800 Series			Foro fil. testa Tapped hole Gewindebohrung Kopf		Cava Keyway Nut			Estremità d'albero Shaft end Wellenende			Linguetta Key Federkeil			
Size	U	S	Size	U	S	Size	U	S	d	f	b	t ₁	t ₂	U	S _{a11}	a	b x h x l
704	14 j6	30	708	14 j6	30	802	14 j6	30	M6	14	5	3	16.3	14 j6	30	2.5	5X5X25
708	19 j6	40	712	19 j6	40	804	14 j6	30	M6	15	6	3.5	21.8	19 j6	40	5	6X6X30
712	24 j6	50	716	24 j6	50	806	19 j6	40	M8	20	8	4	27.3	24 j6	50	5	8X7X40
716	28 j6	60	720	28 j6	60	808	19 j6	40	M8	20	8	4	31.3	28 j6	60	5	8X7X50
720	38 k6	80				810	24 j6	50	M10	27	10	5	41.3	38 k6	80	5	10X8X70
						812	24 j6	50									
						814	28 j6	60									
						816	28 j6	60									

1.13 Accessori

Antiretro

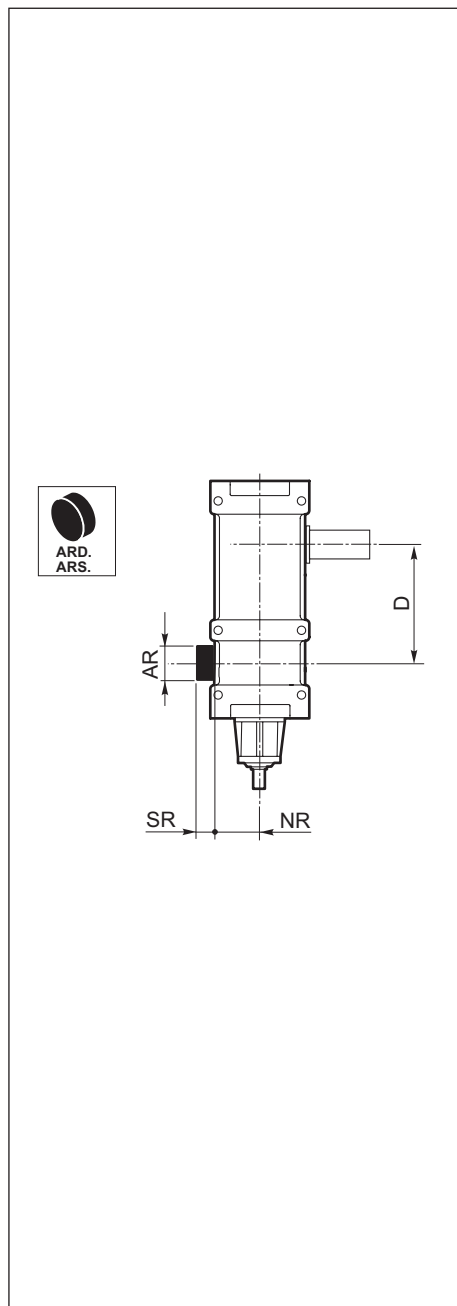
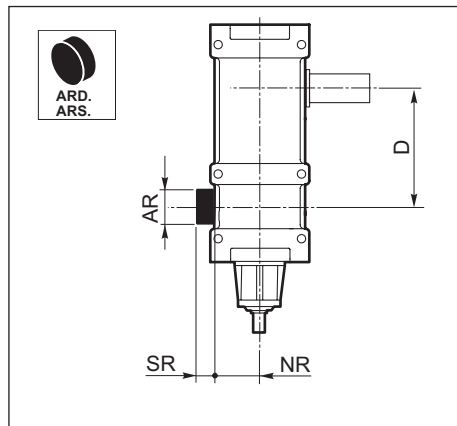

1.13 Accessories

Backstop

RX 700 Series	RXO1 - RXV1			
	NR	SR	AR	D
704	51	14	40	65
708	58.5	13.5	50	80
712	70.5	23	55	100
716	81	29	60	127
720	103.5	21	80	160

RX 700 Series	RXO2 - RXV2			
	NR	SR	AR	D
708	54	11.8	40	141
712	66.5	10	76	180
716	79	14	55	227
720	99	29	60	285

RX 800 Series	RXO1 - RXV1			
	NR	SR	AR	D
802	109.5	60	90	125
804	120.5	60	100	140
806	135.5	60	110	160
808	149.5	60	120	180
810	163.5	90	130	200
812	190	90	150	225
814	212	90	170	250
816	236.5	110	180	280
818	248.5	110	200	320
820 ... 824	A richiesta / On request / Auf anfrage			

RX 800 Series	RXO2 - RXV2			
	NR	SR	AR	D
802	90	41	72	225
804	100	57	80	252
806	112.5	66	90	285
808	125	57	100	320
810	140	58	110	360
812	157.5	63	120	405
814	177.5	86	130	450
816	200	81	150	505
818	225	67	170	570
820	250	97	180	640
822	280	80	190	720
824	315	82	240	810
826	355	115	270	900
828 ... 830	A richiesta / On request / Auf anfrage			

RX 800 Series	RXO3 - RXV3			
	NR	SR	AR	D
802	90	8	56	305
804	100	9	63	342
806	112.5	10	72	385
808	125	11	80	432
810	140	12	90	485
812	157.5	14	100	545
814	177.5	16	110	610
816	200	18	120	685
818	225	20	130	770
820	250	22	150	865
822 ... 832	A richiesta / On request / Auf anfrage			

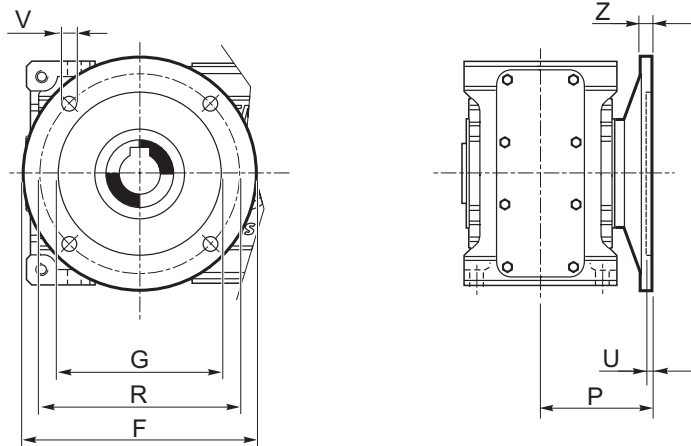

**1.13 Accessori****1.13 Accessories****1.13 Zubehör****Flange di uscita - F****Output flanges -F****Abtriebsflansch -F**

RX 700 Series	704	708	712	716	720
F	160	200	250	300	350
G F8	110	130	180	230	250
R	130	165	215	265	300
P	87	100	125	150	180
U	4	4.5	5	5	6
V	9	11	13	15	17
Z	8	11	14	16	25

1.13 Accessori

1.13 Accessories

1.13 Zubehör

Flange di uscita - F

Output flanges -F

Abtriebsflansch -F

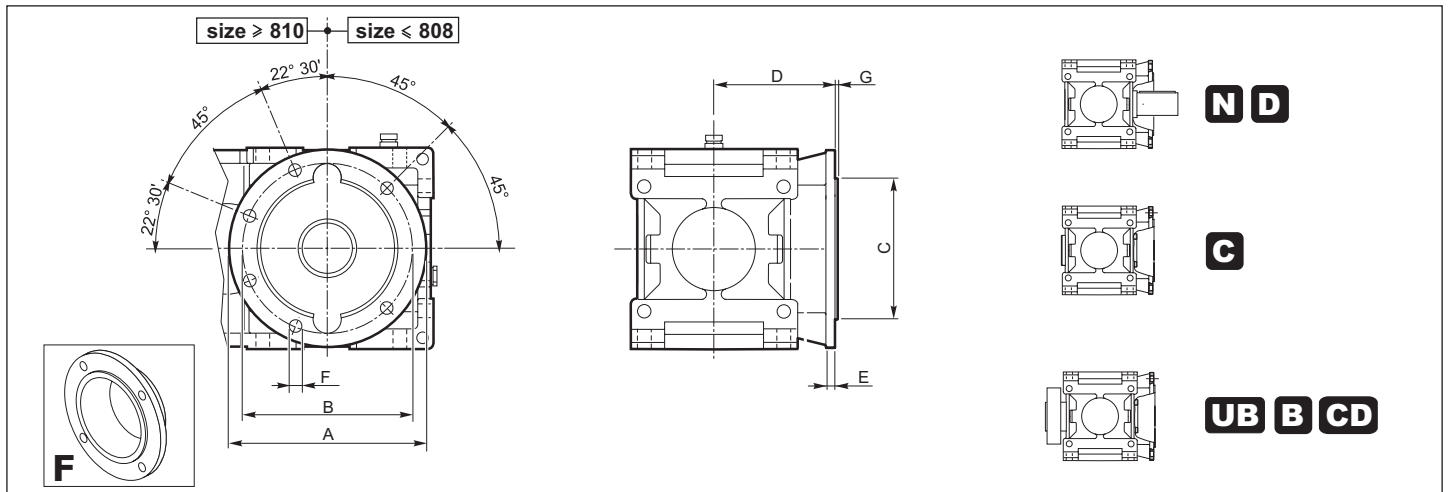

RX 800 Series	A	B	∅ C h7	D	E	F	G
802	250	215	180	155	14	18	5
804	300	265	230	175	14	18	5
806	350	300	250	195	16	20	5
808	350	300	250	215	16	22	5
810	400	350	300	240	16	22	5
812	450	400	350	270	16	24	5
814	550	500	450	300	18	27	7
816	550	500	450	340	20	30	7
818	660	600	550	375	22	33	7
820	660	600	550	410	22	36	7

Flange di uscita - S

Output flanges - S

Abtriebsflansch -S

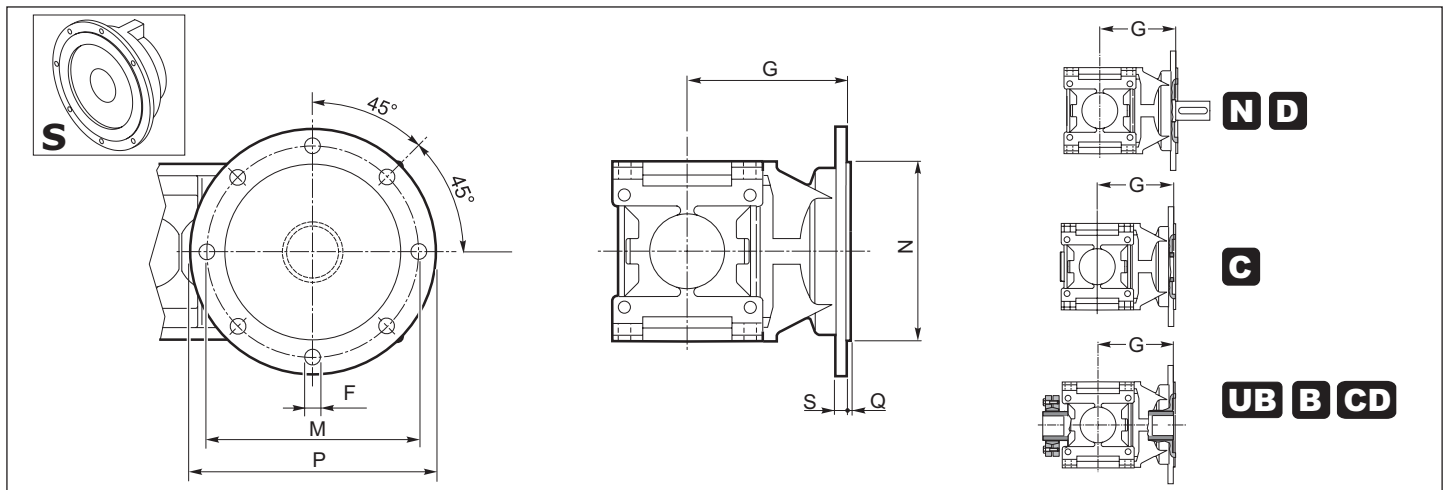

RX 800 Series	F	G	M	N	P	Q	S
802	16	228	300	250	350	4	16
804	16	248	300	250	350	4	18
806	18	268	350	300	400	5	18
808	18	303	400	350	450	5	20
810	20	333	450	400	500	6	20
812	20	372	500	450	550	6	22
814	22	407	550	500	600	7	22
816	25	452	600	550	650	7	25
818	27	502	650	600	700	8	25
820	30	551	750	650	800	8	28



1.13 Accessori

1.13 Accessories

1.13 Zubehör

Sistema con ventola - VE

Fan cooling - VE

System mit Lüfterrad - VE

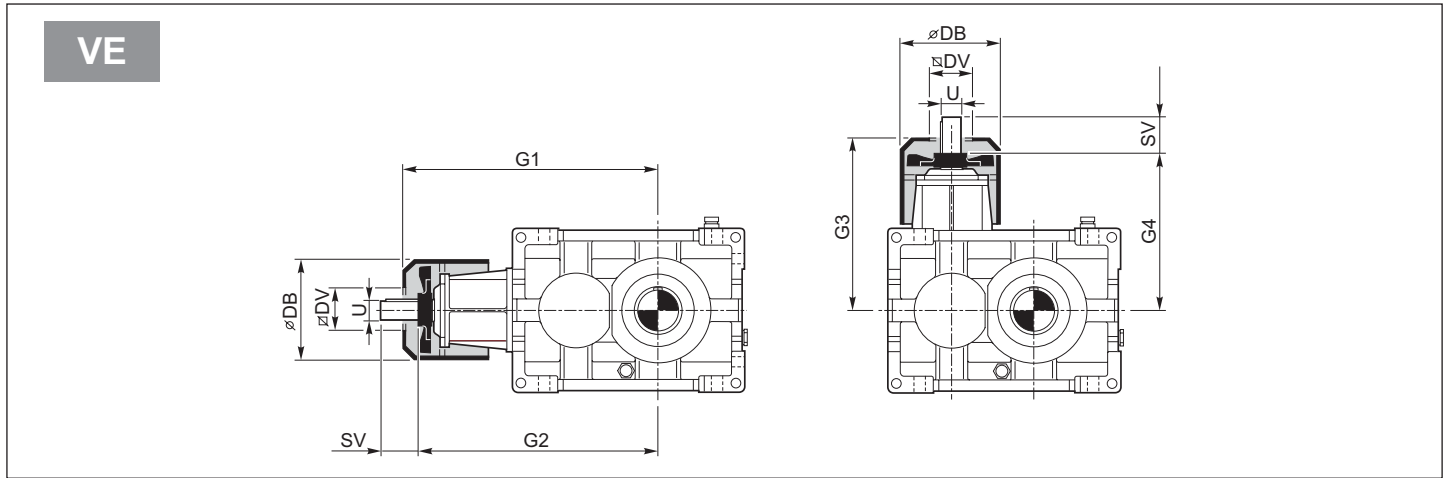

RX800 Series	RXO1 - RXV1													
	G1	G2	G3	G4	$\varnothing DB$	DV \varnothing	SV						U	
							i<11	i<12	i<13	i>11	i>12	i>13		
802	403	369	278	244	176	89		31				31		28 j6
804	454	416	314	276	220	98		30				30		32 k6
806	504	466	343	306	220	98		37				37		35 k6
808	557	521	377	341	220	98	70				44			40 k6
810	633	585	433	385	260	118		80				50		45 k6
812	702	655	477	430	260	118		90				60		50 m6
814	793	738	543	488	310	138		100				62		55 m6
816	871	818	591	538	310	138		112				74		60 m6
818	1009	930	689	610	394	214				125			75	70 m6
820	1116	1040	756	680	394	214	140				90			80 m6

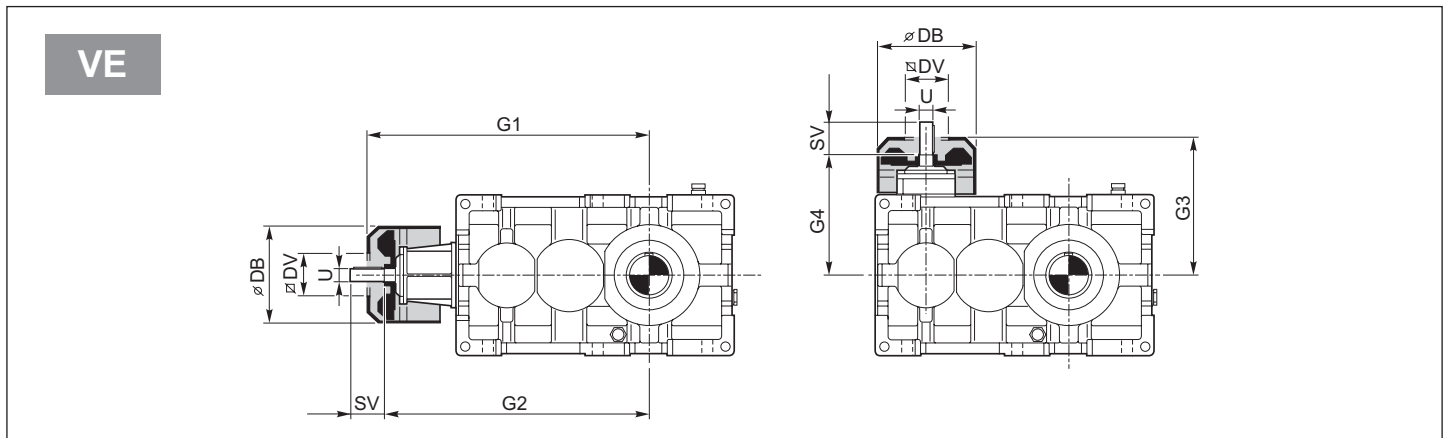

RX 800 Series	RXO2 - RXV2									
	G1	G2	G3	G4	$\varnothing DB$	$\varnothing DV$	SV RX02 i \leq 47.5	SV RX02 i $>$ 47.5	U	
806	563	529	281	244	176	89	31	31	28 k6	
808	634	596	314	276	220	98	30	30	32 k6	
810	704	666	344	306	220	98	37	37	35 k6	
812	782	746	377	341	220	98	70	44	40 k6	
814	883	835	385	393	260	118	80	50	45 k6	
816	983	935	430	438	260	118	90	60	50 k6	
818	1113	1058	543	488	310	138	100	62	55 m6	
820	1231	1178	591	538	310	138	112	74	60 m6	

1.13 Accessori

1.13 Accessories

1.13 Zubehör

Sistema con ventola - **VEMB-VEMN**

Fan cooling - **VEMB-VEMN**

System mit Lüfterrad- **VEMB-VEMN**

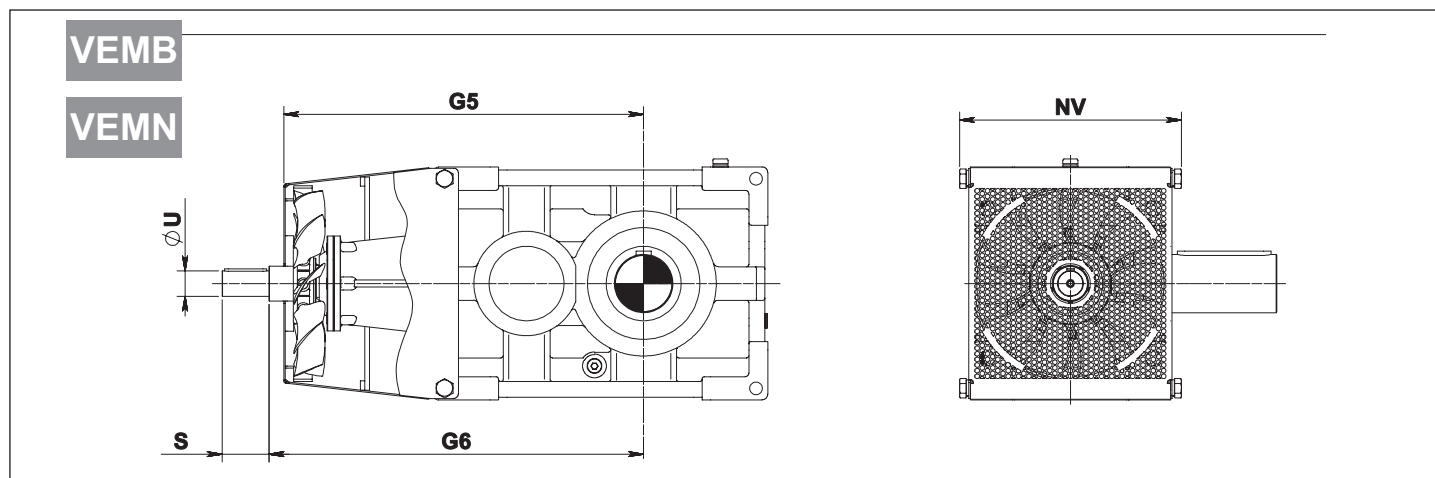

RX 800 Series	RXO1					
	G5	G6	NV	S	U	ir max
808	541	561	334	70	40 k6	10,7
810	613	638	375	80	45 k6	11,7
812	683	708	423	90	50 m6	11,9
814	768	800	473	100	55 m6	11,2
816	848	876	530	112	60 m6	11,7
818	967	996	600	125	70 m6	12,9
820	1086	1120	663	140	80 m6	10,9
822	1213	1250	744	160	90 m6	10,8
824	A richiesta - On request - Auf Anfrage					

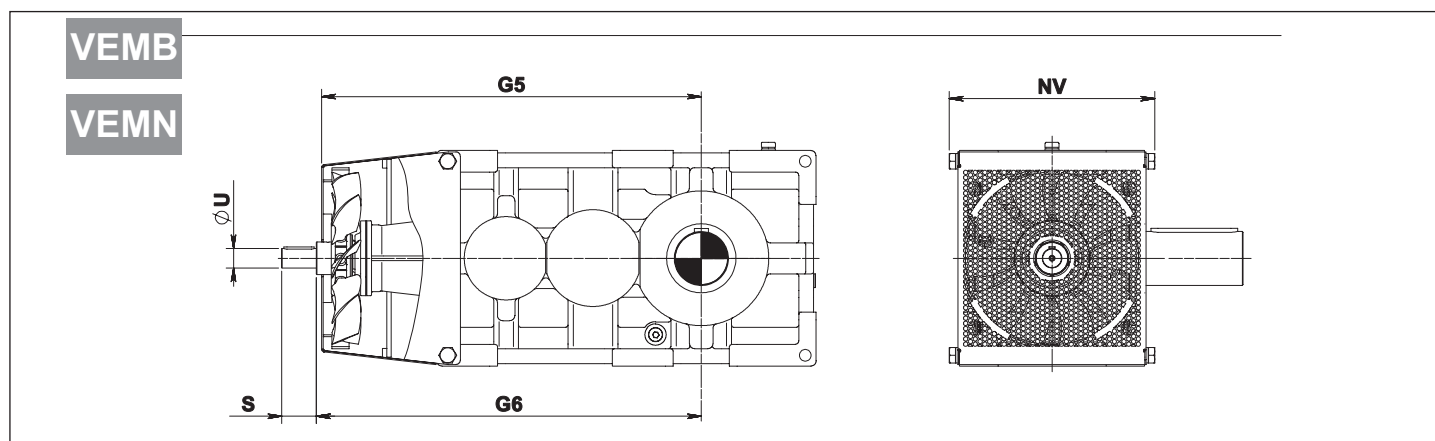

RX 800 Series	RXO2					
	G5	G6	NV	S	U	ir max
812	781	786	423	70	40 k6	45,3
814	875	888	473	80	45 k6	46,0
816	977	988	530	90	50 m6	45,9
818	1104	1120	600	100	55 m6	44,1
820	1225	1236	663	112	60 m6	46,8
822	1387	1396	744	125	70 m6	52,5
824	1558	1570	832	140	80 m6	46,1
826	1738	1750	936	160	90 m6	50,9
828	A richiesta - On request - Auf Anfrage					

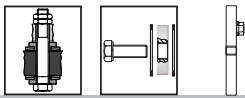

1.14 KIT

Kit bullone di reazione

1.14 KIT

Torque arm kit

1.14 KIT

Kit Momentenstütze

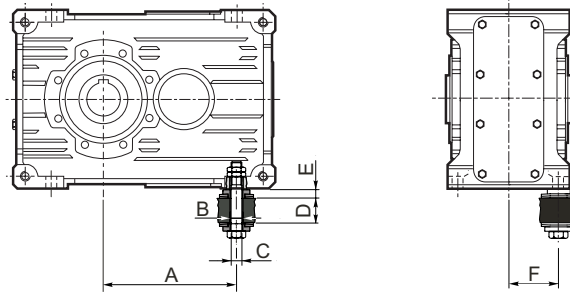

RX 700 Series	A				B	C	D		E	F	Molle a tazza Belleville washers Tellerfedern	
	RXO1 RXV1	RXO2 RXV2	MIN	MAX			N. 2 Molle a Tazza 2 Belleville washers 2 Tellerfedern	Y (*)				
704	102	—			9	M8	13	23	8.5	45	31.5x16.3x1.25	0.5
708	134	188			11	M10	16	28	9.2	52	31.5x16.3x1.75	0.5
712	166	236			13	M12	18	32	10	62.5	40x20.4x2	0.5
716	209	296			15	M14	20	35	12	72.5	40x20.4x2.5	0.5
720	272.5	379.5			17	M16	22	38	14	90	50x25.4x3	0.5

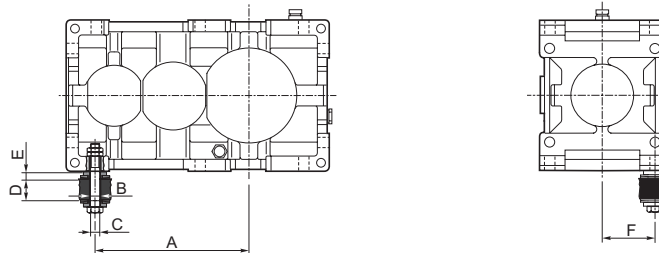

RX 800 Series	A				B	C	D		E	F	Molle a tazza Belleville washers Tellerfedern	
	RXO1 RXV1	RXO2 RXV2	RXO3 RXV3	RXO4			MIN	MAX			N. 4 Molle a tazza 4 Belleville washers 4 Tellerfedern	Y (*)
802	175	225	318	399	20	M16	25	38	13	90	50x25.4x2.5	0.6
804	196	286	355.5	431.5	20	M16	25	38	13	100	50x25.4x2.5	0.6
806	222	322	402	495	24	M20	29	45	16	112.5	63x31x3.5	0.8
808	250	362	452	538	24	M20	29	45	16	125	63x31x3.5	0.8
810	280	405	504	625	30	M24	29	45	19	140	70x35.5x4	0.8
812	315	455	566.5	679.5	30	M24	29	45	19	157.5	70x35.5x4	0.8
814	350	510	634	785	36	M30	37	70	23	177.5	100x51x5	1
816	393	573	712.5	848.5	39	M33	37	70	23	200	100x51x5	1
818	445	645	805	805	39	M33	45	70	23	225	100x51x5	1
820	500	725	904.5	904.5	42	M36	45	80	29	250	125x61x6	1.3

(*) Valore di compressione delle molle

(*) Spring compression value

(*) Wert der Federkompression

Kit rosetta di montaggio

Mounting washer kit

Kit Montagescheibe

	<p>Kit rosetta di montaggio Mounting washer kit Kit Montagescheibe</p>	<p>Alberi Uscita- "C" - "UB" - "B" Output Shafts - "C" - "UB" - "B" Abriebswellen - "C" - "UB" - "B"</p>
--	--	--

FF - Kit

FF - kit

FF - Kit

	<p>FF - Kit FF - kit FF - Kit</p>	<p>Alberi Uscita- "FD" Output Shafts - "FD" Abriebswellen - "FD"</p>
--	---	--